

THIS DRAWING IS UNPUBLISHED.

RELEASED FOR PUBLICATION

ALL RIGHTS RESERVED.

© COPYRIGHT - By -

LOC AF DIST 50

REVISIONS

P	LTR	DESCRIPTION	DATE	DWN	APVD
D1		REVISED PER ECR-20-009164	27JUL2020	MK	DH

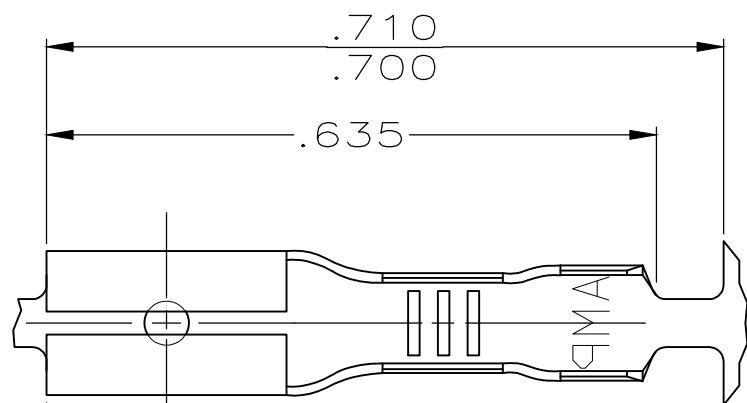

GAP AS REQUIRED TO MEET FORCE SPECIFICATIONS AND .028 MAX

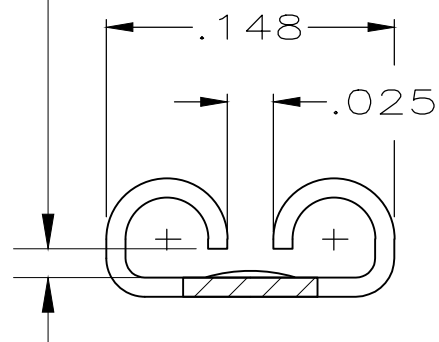

VIEW Z-Z SCALE 10:1

- 1 CONTINUOUS STRIP ON REELS
- 2 WIRE SIZE IS #22-#18 AWG
- 3 INSULATION RANGE IS .060-.100 DIA
- 4 MATING TAB THK IS .033-.030
- 5 REELED WITH INTERLEAVING PAPER
- 6 PRELIMINARY - NOT FOR PRODUCTION

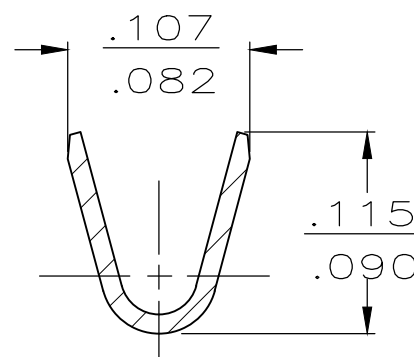
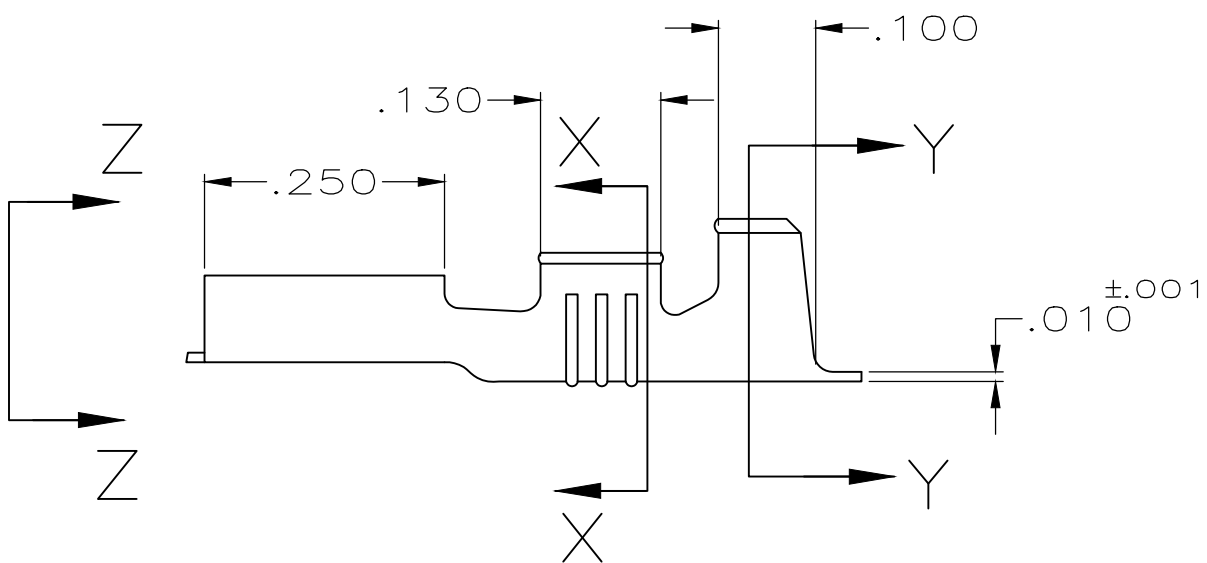

SECTION X-X SCALE 10:1

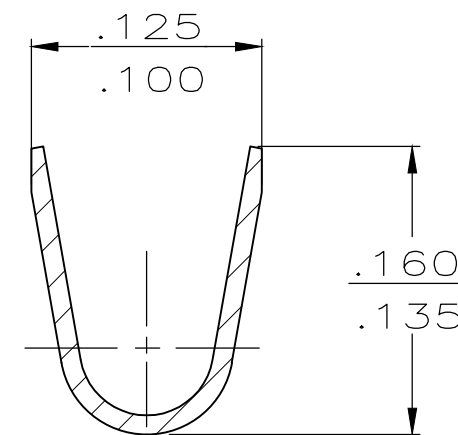

SECTION Y-Y SCALE 10:1

6	5	60577-2
		60577-1
		WIRE SIZE

THIS DRAWING IS A CONTROLLED DOCUMENT.		DWN JR RUTH 12/20/90	TE Connectivity						
DIMENSIONS: INCHES 		CHK MS FEHER 12/20/90							
TOLERANCES UNLESS OTHERWISE SPECIFIED: 0 PLC ± - 1 PLC ± - 2 PLC ± - 3 PLC ± .015 4 PLC ± - ANGLES ± -		APVD D REINER 12/20/90	NAME RECEPTACLE, FASTON, .110 SERIES						
MATERIAL BRASS		FINISH PRE-TIN	PRODUCT SPEC -	APPLICATION SPEC -	WEIGHT -	SIZE A3	CAGE CODE 00779	DRAWING NO C-60577	RESTRICTED TO -
CUSTOMER DRAWING			SCALE 5:1	SHEET 1 OF 1	REV D1				