

APPROVED: _____
 DATE: _____ TITLE: _____

Rev	AWO #	Description	Date	Appr
-		RELEASED	11/10/20	
A		UPDATE DRAWING	5/12/21	JJ/RC
B		ADDED SEPC.	8/31/21	WX/RC
C		ADDED SEPC.	6/15/22	WX/MC

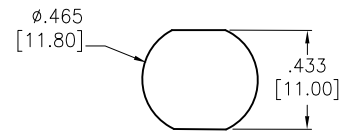
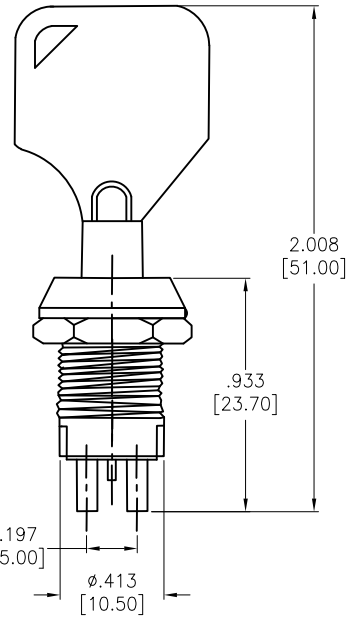
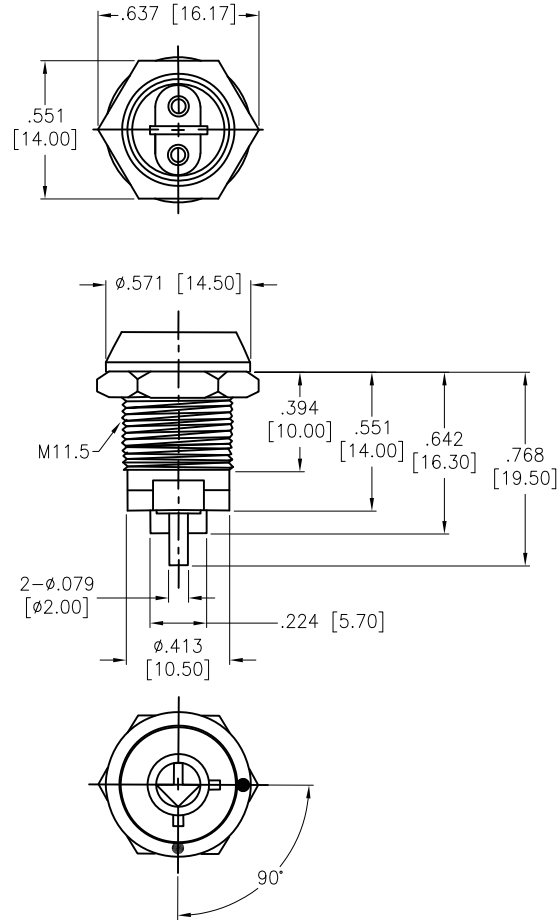

RECOMMENDED PANEL CUT

FUNCTION
SPST, ON-OFF

ADAM-P/N	SPEC.
SW-R-K5-A	Key pulled on both positions. Note: this would be our standard
SW-R-K5-B	Key pulled on 1 position

SPECIFICATIONS:

Material:
 Body: Steel, Polished Chrome, Silver plated
 Electrical:
 The rated load: 125 VAC, 1A
 250 VAC, 0.5A
 Contact resistance: 100 mΩ max
 Insulation resistance: 100 mΩ min (500VDC)
 Dielectric withstanding voltage: 500 VAC for 1 minute
 Mechanical life: 5000 times max
 Temperature Rating:
 -25°C to +85°C
 Environmental:
 Lead free, RoHS compliant



UNLESS OTHERWISE SPECIFIED ALL DIMENSIONS ARE INCHES [MM]. TOLERANCES: EXCEPT AS NOTED

INCHES		HOLES	
.x	±.10	∅x	±.10
.xx	±.020	∅xx	±.015
.xxx	±.015	∅xxx	±.010



909 Rahway Avenue,
 Union, NJ 07083
 Phone: 908-687-5000
 Fax: 908-687-5710

DRAWN	OW	11/10/20
CHECKED	AC	11/10/20
APPROVED		

TITLE	SWITCH, KEY LOCK, SPST, ON-OFF PANEL MOUNT, SOLDER TERMINAL	
SIZE	PART NO.	REV.
X	SW-R-K5-X	C

THIS DRAWING CONTAINS INFORMATION THAT IS PROPRIETARY AND SHOULD NOT BE USED WITHOUT PRIOR WRITTEN PERMISSION FROM ADAM TECH

REF:	S00206C	SCALE:	NTS	SHEET	1 OF 1
------	---------	--------	-----	-------	--------