



High Speed CMOS 16-Bit Buffers/Line Drivers in QVSOP™

QS74FCT2X240T
QS74FCT2X244T
QS74FCT2X2244T

FEATURES/BENEFITS

- 16-bit Function compatible to the 74F240/4, 74ABT240/4 and 74FCT240/4T
- CMOS power levels: <15 mW static
- Available in 40-pin QVSOP™ (Q2)
- TTL-compatible input and output levels
- Ground bounce controlled outputs
- Reduced output swing of 0-3.5V
- Undershoot clamp diodes on all inputs

FCT-T 2X240T, 2X244T

- JEDEC-FCT spec compatible
- Fastest CMOS logic family available
- A and C speed grades; 4.1 ns t_{PD} for C
- I_{OL} = 64 mA Com.

FCT-T 2X2244T

- Built-in 25Ω series resistor outputs reduce reflection and other system noise
- A and C speed grades; 4.1 ns t_{PD} for C
- I_{OL} = 12 mA

DESCRIPTION

The FCT2X240T and FCT2X244T are 16-bit buffer/line drivers with three-state outputs that are ideal for driving high-capacitance loads as in memory address and data buses. The FCT2X2244T is a 25Ω resistor output version useful for driving transmission lines and reducing system noise. All inputs have clamp diodes for undershoot noise suppression. All outputs have ground bounce suppression (see QSI Application Note AN-001), and outputs will not load an active bus when V_{CC} is removed from the device.

FUNCTIONAL BLOCK DIAGRAM

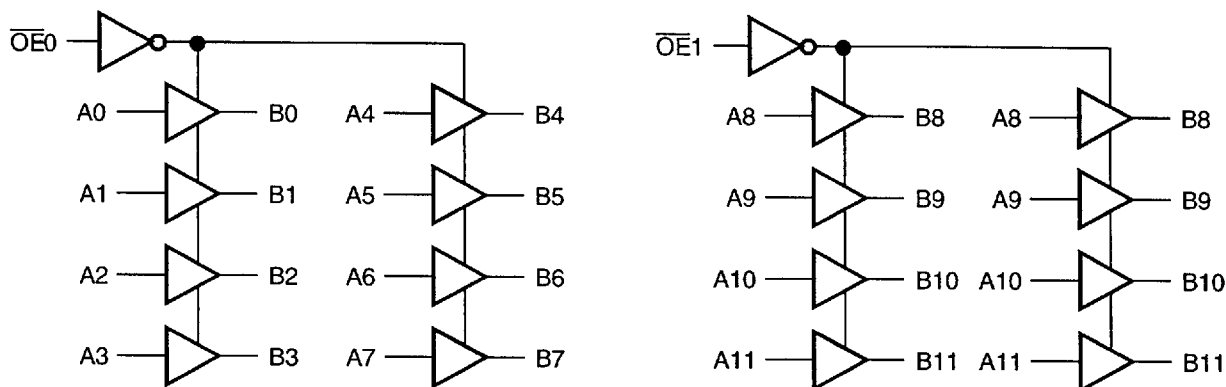

Note: Outputs are inverting for the QS74FCT2X240.

PIN CONFIGURATION
(All Pins Top View)

FCT2X244

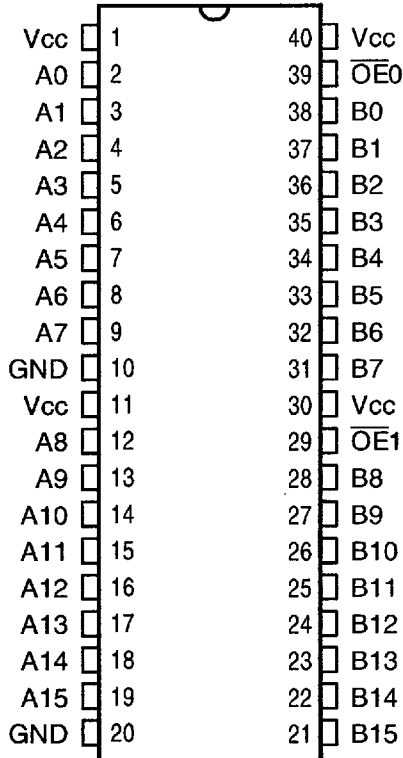

FCT2X240

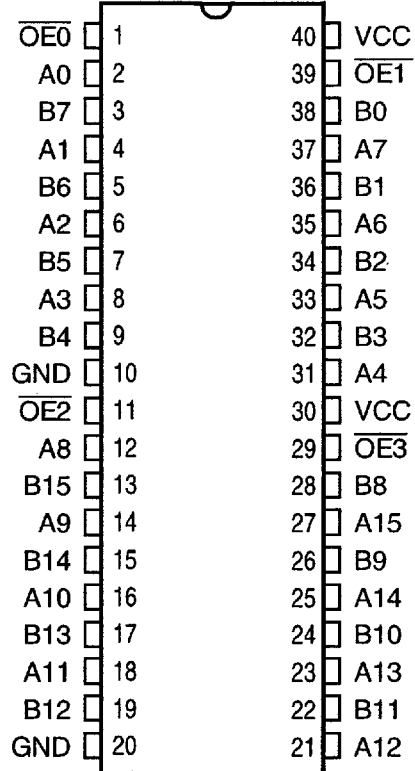

PIN DESCRIPTION (FCT2X244, FCT2X2244)

Name	I/O	Description
Ai	I/O	Data Bus A Inputs
Bi	I/O	Data Bus B Outputs
OE0	I	Output Enables for A/B7-A/B0
OE1	I	Output Enables for A/B15-A/B8

FUNCTION TABLE (FCT2X244, FCT2X2244)

OE _n	Input A	Output B
H	X	Hi-Z
L	L	L
L	H	H

PIN DESCRIPTION (FCT2X240)

Name	I/O	Description
1Ai-4Ai	I/O	Data Bus A Input Ports
1Bi-4Bi	I/O	Data Bus B Input Ports
OE0	I	Output Enables for A/B0-A/B3
OE1	I	Output Enables for A/B4-A/B7
OE2	I	Output Enables for A/B8-A/B11
OE3	I	Output Enables for A/B12-A/B15

FUNCTION TABLE (FCT2X240)

OE _n	Input A	Output B
H	X	Hi-Z
L	L	H
L	H	L

ABSOLUTE MAXIMUM RATINGS

Supply Voltage to Ground	-0.5V to +7.0V
DC Output Voltage V_{OUT}	-0.5V to +7.0V
DC Input Voltage V_{IN}	-0.5V to +7.0V
AC Input Voltage (for a pulse width ≤ 20 ns)	-3.0V
DC Input Diode Current with $V_{IN} < 0$	-20 mA
DC Output Diode Current with $V_{OUT} < 0$	-50 mA
DC Output Current Max. Sink Current/Pin	120 mA
Maximum Power Dissipation	1.2 watts
T_{STG} Storage Temperature	-65° to +150°C

Note: Stresses greater than those listed under ABSOLUTE MAXIMUM RATINGS may cause permanent damage to this device resulting in functional or reliability type failures.

CAPACITANCE

$T_A = 25^\circ\text{C}$, $f = 1$ MHz, $V_{IN} = 0V$, $V_{OUT} = 0V$

Pins (2X244, 2X2244)	PINS (FCT2X240)	Typ	Unit
29, 39	1, 2, 4, 6, 8, 11, 12, 14, 16, 18, 21, 23, 25, 27, 29, 31, 33, 35, 37, 39	4	pF
—	3, 5, 7, 9, 13, 15, 17, 19, 22, 24, 26, 32, 34, 36, 38	6	pF
2-9, 12-19, 21-28, 31-38	—	8	pF

Note: Capacitance is characterized but not tested.

QS74FCT2X240T, QS74FCT2X244T, QS74FCT2X2244T PRELIMINARY

DC ELECTRICAL CHARACTERISTICS OVER OPERATING RANGE

Commercial $T_A = 0^\circ\text{C}$ to 70°C , $V_{CC} = 5.0\text{V} \pm 5\%$

Symbol	Parameter	Test Conditions	Min	Typ ⁽¹⁾	Max	Unit
V_{IH}	Input HIGH Voltage	Logic HIGH for All Inputs	2.0	—	—	V
V_{IL}	Input LOW Voltage	Logic LOW for All Inputs	—	—	0.8	V
ΔV_T	Input Hysteresis	$V_{TLH} - V_{THL}$ for All Inputs ⁽³⁾	—	0.2	—	V
$ I_{IH} $ $ I_{IL} $	Input Current Input HIGH or LOW	$V_{CC} = \text{Max.}, 0 \leq V_{IN} < V_{CC}$	—	—	5	μA
$ I_{OZ} $	Off-State Output Current (Hi-Z)	$V_{CC} = \text{Max.}, 0 \leq V_{IN} \leq V_{CC}$	—	—	5	μA
I_{OS}	Short Circuit Current FCT2X240/4	$V_{CC} = \text{Max.}, V_{OUT} = \text{GND}^{(2,3)}$	-60	—	-225	mA
I_{OR}	Current Drive FCT2X2244 (25 Ω)	$V_{CC} = \text{Max.}, V_{OUT} = 2.0\text{V}$	50	—	—	mA
V_{IC}	Input Clamp Voltage	$V_{CC} = \text{Min.}, I_{IN} = -18 \text{ mA}^{(3)}$	—	-0.7	-1.2	V
V_{OH}	Output HIGH Voltage	$V_{CC} = \text{Min.}, I_{OH} = -15 \text{ mA}$	2.4	—	—	V
V_{OL}	Output LOW Voltage FCT2X240/4	$V_{CC} = \text{Min.}, I_{OL} = 64 \text{ mA}$	—	—	0.55	V
V_{OL}	Output LOW Voltage FCT2X2244 (25 Ω)	$V_{CC} = \text{Min.}, I_{OL} = 12 \text{ mA}$	—	—	0.50	V
R_{OUT}	Output Resistance FCT2X2244 (25 Ω)	$V_{CC} = \text{Min.}, I_{OL} = 12 \text{ mA}$	20	28	40	Ω

Notes:

1. Typical values indicate $V_{CC} = 5.0\text{V}$ and $T_A = 25^\circ\text{C}$.
2. Not more than one output should be shorted and the duration is ≤ 1 second.
3. These parameters are guaranteed by design but not tested.

POWER SUPPLY CHARACTERISTICS

Symbol	Parameter	Test Conditions ⁽¹⁾	Min	Max	Unit
I _{cc}	Quiescent Power Supply Current	V _{CC} = Max., Freq = 0 0V ≤ V _{IN} ≤ 0.2V or V _{CC} -0.2V ≤ V _{IN} ≤ V _{CC}	—	3.0	mA
ΔI _{cc}	Supply Current per Input @ TTL HIGH	V _{CC} = Max., V _{IN} = 3.4V, Freq = 0 ⁽²⁾	—	2.0	mA
Q _{CCD}	Supply Current per Input per MHz	V _{CC} = Max., Outputs Open and Enabled One Bit Toggling @ 50% Duty Cycle Other Inputs at GND or V _{CC} ^(3,4)	—	0.25	mA/ MHz

Notes:

- For conditions shown as Min. or Max., use the appropriate values specified under DC specifications.
- Per TTL driven input (V_{IN} = 3.4V).
- For flip-flops, Q_{CCD} is measured by switching one of the data input pins so that the output changes every clock cycle. This is a measurement of device power consumption only and does not include power to drive load capacitance or teste capacitance. This parameter is guaranteed by design but not tested.
- I_c can be computed using the above parameters as explained in the Technical Overview section.

SWITCHING CHARACTERISTICS OVER OPERATING RANGE

Commercial T_A = 0°C to 70°C, V_{CC} = 5.0V ± 5%

C_{LOAD} = 50 pF, R_{LOAD} = 500Ω unless otherwise noted.

Symbol	Description ⁽¹⁾	2X240A 2X244A 2X2244A		2X240C 2X244C 2X2244C		Unit
		Min	Max	Min	Max	
t _{PHL} t _{PLH}	Propagation Delay A _i to B _i , FCT2X240/4	1.5	4.8	1.5	4.1	ns
t _{PHL} t _{PLH}	Propagation Delay A _i to B _i , FCT2X2244	1.5	4.8	1.5	4.1	ns
t _{PZH} t _{PZL}	Output Enable Time \overline{OE} to B _i , FCT2X240/4	1.5	6.2	1.5	5.8	ns
t _{PZH} t _{PZL}	Output Enable Time \overline{OE} to B _i , FCT2X2244	1.5	6.2	1.5	5.8	ns
t _{PHZ} t _{PLZ}	Output Disable Time ⁽²⁾ \overline{OE} to B _i	1.5	5.6	1.5	5.2	ns

Notes:

- Minimums guaranteed but not tested. See Test Circuit and Waveforms.
- This parameter is guaranteed but not tested.

PACKAGING INFORMATION

150-MIL QVSOP™ - Package Code Q1/Q2 150-Mil Wide Plastic Small Outline Gull-Wing

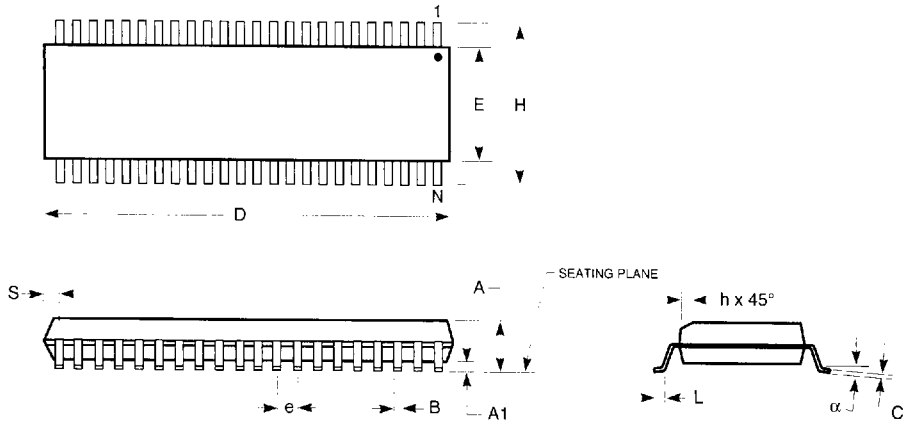

JEDEC#	MO-154BB			MO-154AB		
	PSS-40A (Q2)			PSS-48A (Q1)		
DWG#	Min	Nom	Max	Min	Nom	Max
A	0.059	0.065	0.069	0.059	0.065	0.069
A1	0.004	0.006	0.008	0.004	0.006	0.008
B	0.0067	0.008	0.009	0.0051	0.0063	0.008
C	0.0075	0.008	0.0098	0.0075	0.008	0.0098
D	0.386	0.390	0.394	0.386	0.390	0.394
E	0.150	0.154	0.157	0.150	0.154	0.157
e	0.0197 BSC, 0.5mm			0.0157 BSC, 0.4mm		
H	0.228	0.236	0.244	0.228	0.236	0.244
h	0.010	0.013	0.016	0.010	0.013	0.016
L	0.020	0.024	0.030	0.020	0.024	0.030
N	40			48		
α	0°	5°	8°	0°	5°	8°
S	0.006	0.008	0.010	0.012	0.014	0.016

Notes:

1. Refer to applicable symbol list.
2. All dimensions are in inches.
3. N is the number of lead positions.
4. Dimensions D and E are to be measured at maximum material condition but do not include mold flash. Allowable mold flash is 0.006 in. per side.
5. Lead coplanarity is 0.003 in. maximum.

7466803 0003420 142