

LOC		DIST		REVISIONS				DATE	APPD
CM	53	P	F	ZONE	LTR	DESCRIPTION			
				A1		REVISED PER ECR-21-117154	01AUG2022	PJ VS	

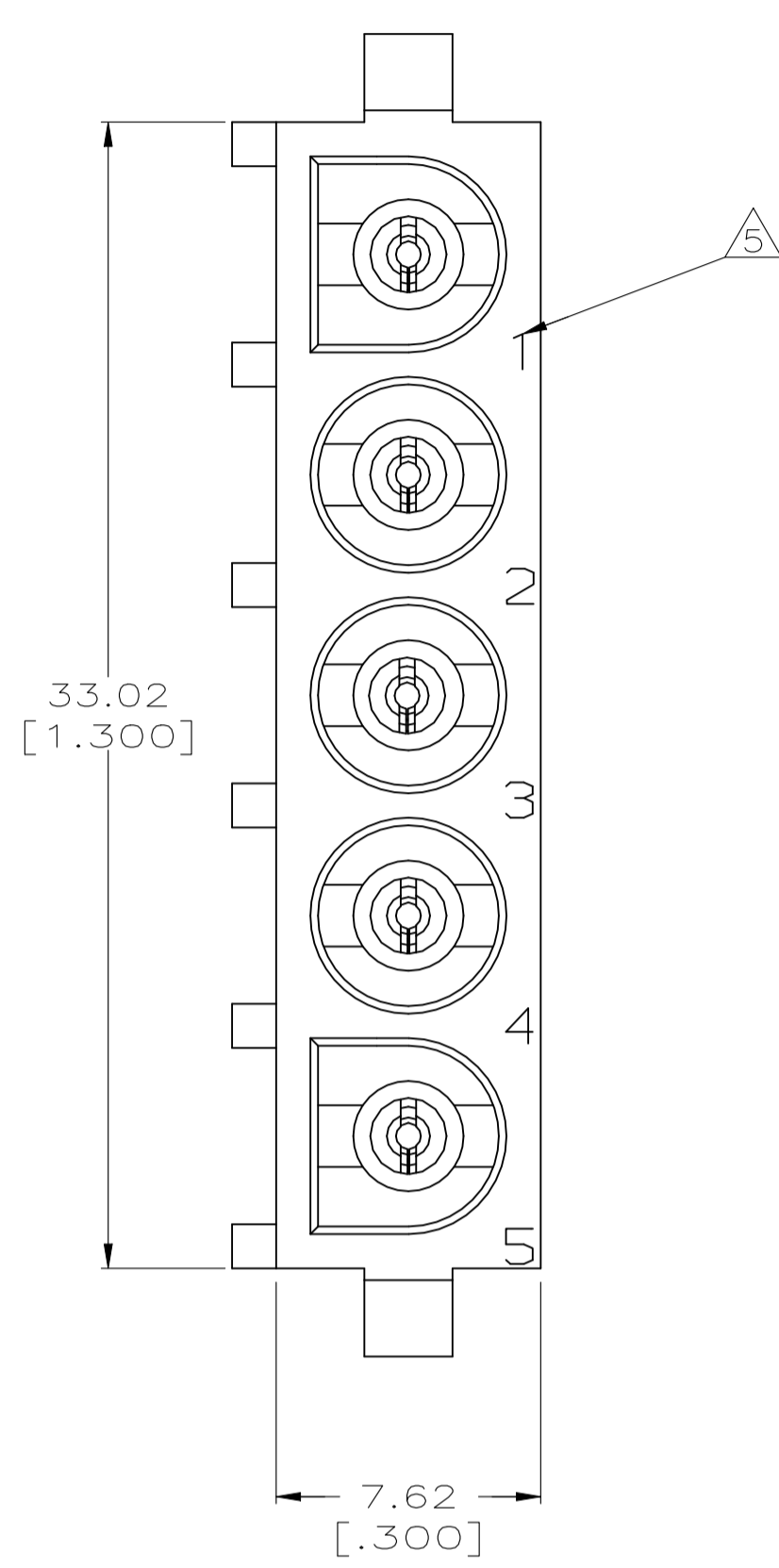

- PARTS COMPLY WITH AMP SOLDERABILITY SPECIFICATION 109-11-3.
- DIMENSIONS IN BRACKETS ARE IN INCHES.
- CIRCUIT IDENTIFICATION CHARACTERS ARE ADJACENT TO THE INDICATED CAVITIES, BUT LOCATION AND ORIENTATION MAY DIFFER FROM PRINT.
- DIMENSION SHOWN REPRESENT PRODUCT IN DRY CONDITION. ADDITIONAL 2% GROWTH DUE TO END USE LOCATION MOISTURE ABSORPTION MAY OCCUR AND SHOULD BE ACCOUNTED FOR.

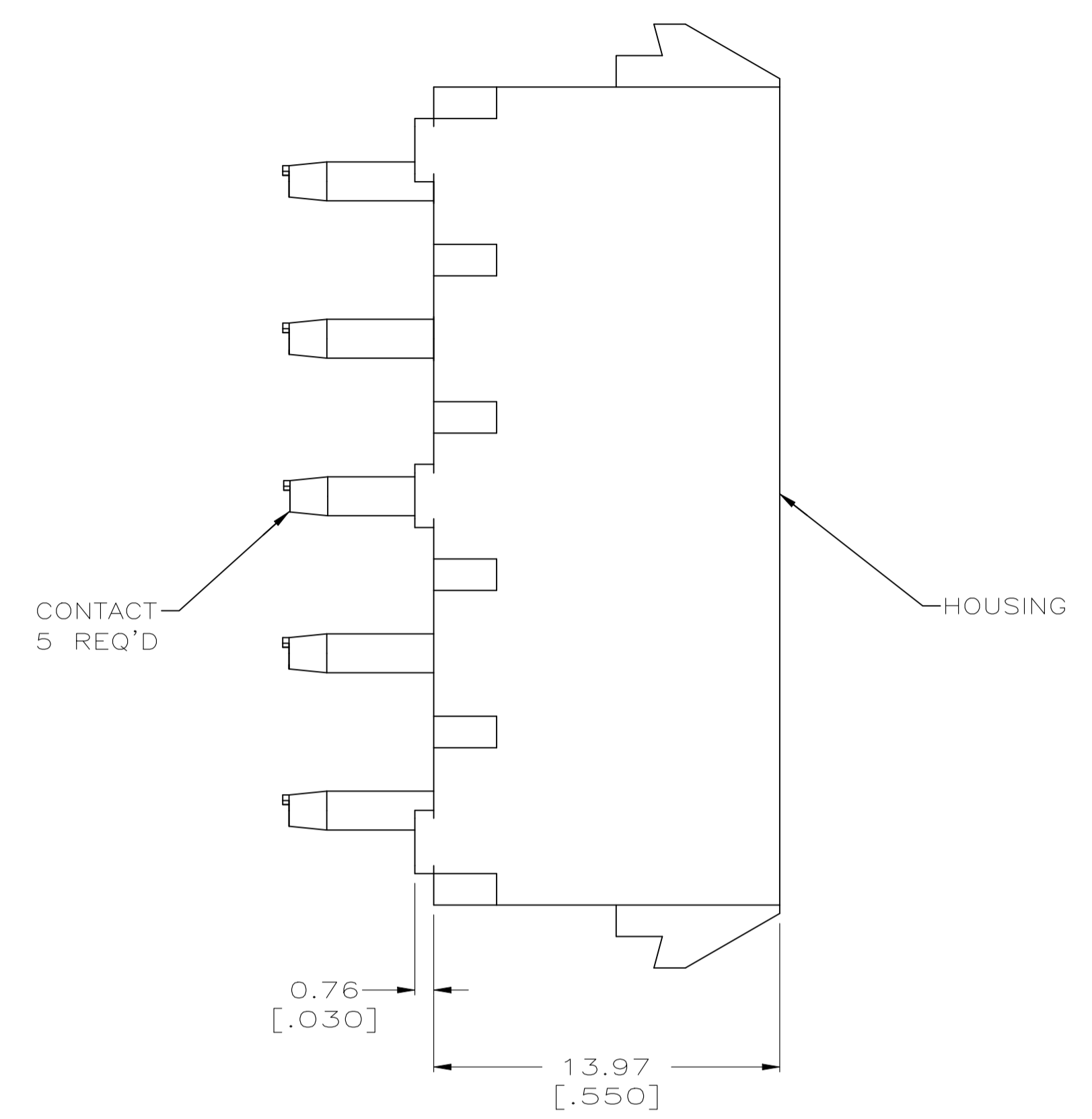
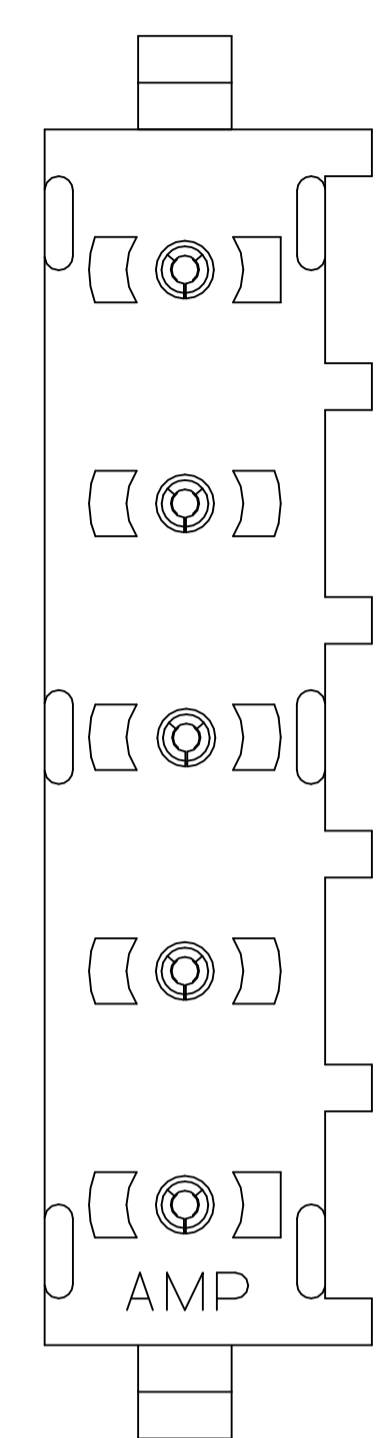

RECOMMENDED MOUNTING HOLE PATTERN FOR 3.18 [.125] THICK P.C. BOARD

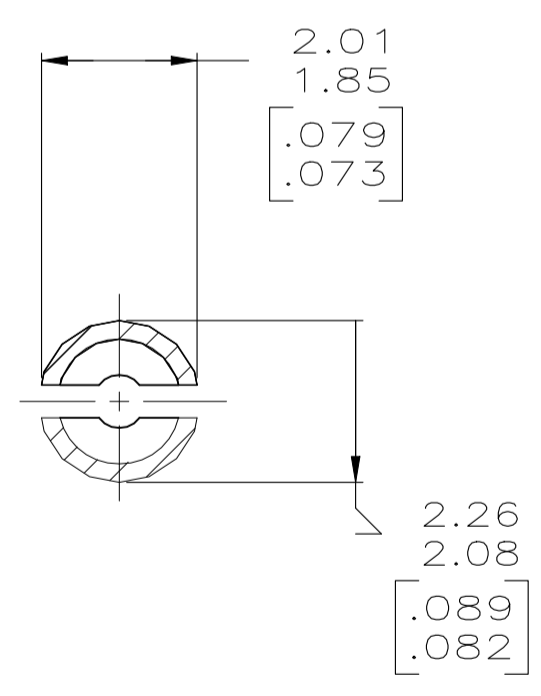
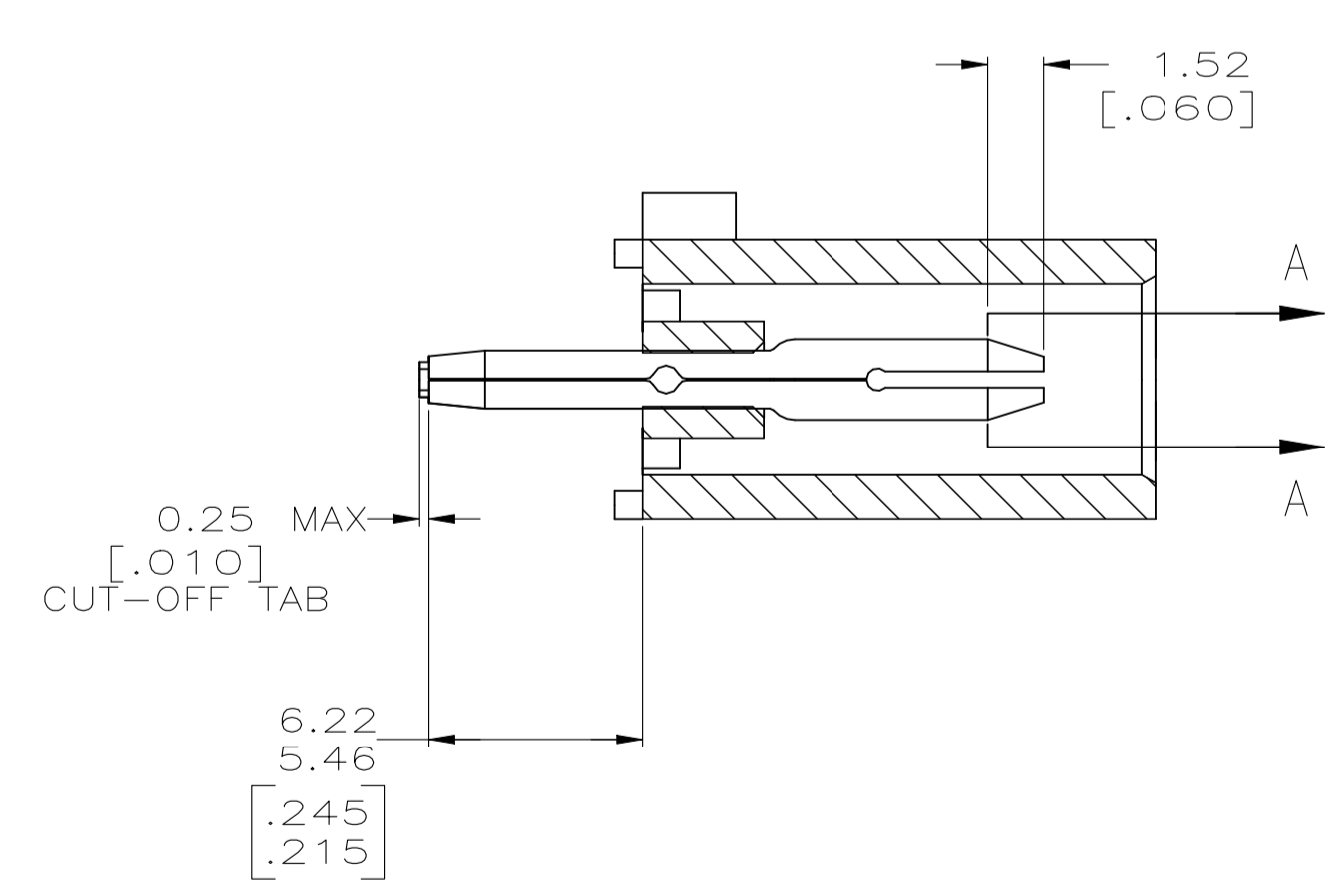

SECTION A-A SCALE 10:1

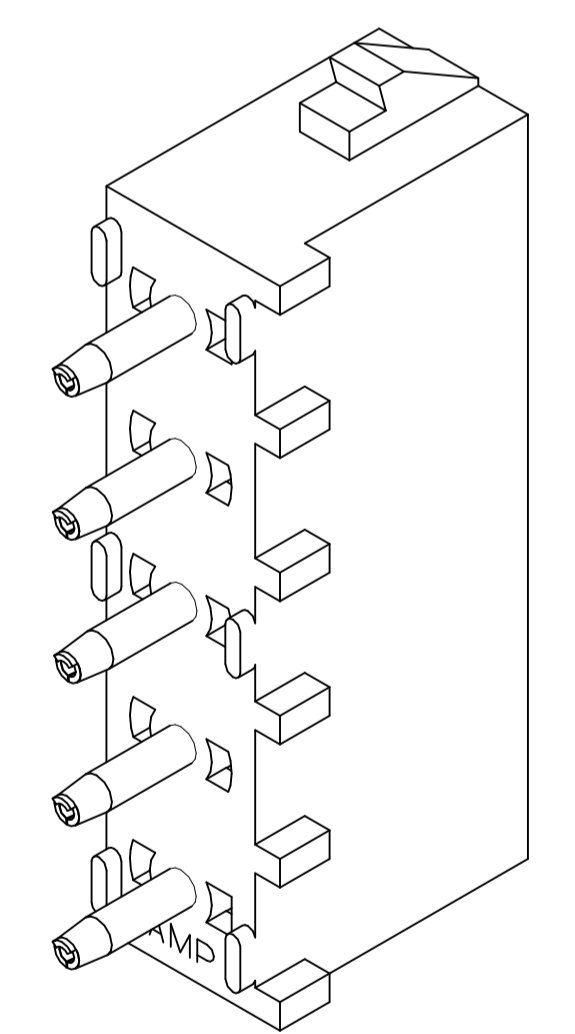

3-DIMENSIONAL MODEL NTS

METRIC

THIS DRAWING IS A CONTROLLED DOCUMENT FOR AMP INCORPORATED. IT IS SUBJECT TO CHANGE AND THE CONTROLLING ENGINEERING ORGANIZATION SHOULD BE CONTACTED FOR THE LATEST REVISION.

PHOSPHOR BRONZE, PRE-TIN	NYLON, UL94V-0, WHITE	794283-1
PIN CONTACT MATERIAL AND FINISH	HOUSING MATERIAL	PART NO
DO NOT SCALE PRINT, UNLESS SPECIFIED	2-20-97 R. VESTAL	AMP Incorporated Harrisburg, PA 17105-3608
DIMENSIONS IN mm [INCHES]	CHK 2-20-97 R. SWING	
TOLERANCES ON :	APPD 2-20-97 M. TRULL	
2 PLC DEC ± 0.13 [.005]	APPD 2-20-97 M. TRULL	
MATERIAL	PRODUCT SPEC	NAME
SEE TABLE	-	PIN HEADER ASSEMBLY, 5 CIRCUIT, UNIVERSAL MATE-N-LOK™
FINISH	APPLICATION SPEC	SIZE
SEE TABLE	-	D
WEIGHT	-	CAGE CODE
		00779
		DRAWING NO
		C-794283
		SCALE
		5:1
		SHEET
		10F 1