

PRODUCT NO.
SEE TABLE

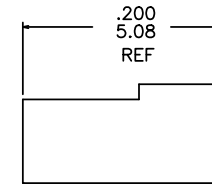

mat'l. code		surface		tolerance		projection		product family	
		ISO 1302		ISO 406		ASME Y14.5		JUMPER	
title		tolerances unless otherwise specified		linear		INCH/MM		S. R. MULTI POSITION	
A RELEASE JGS 4/1/91		angles		.001±.01/.3		scale 1:1		LOW PROFILE JUMPER ASS'Y	
B V11440 MRC 7/19/91		0°±2°		.000±.005/.13				dwg no 69146	
C V80322 SAR 5/21/98				.000±.0020/.05				sheet of 2 size A3	
D M05-0205 ERE 09/29/05 dr		J. SHREINER		4/1/91		FCI		type Product Customer Drawing	
E M06-0238 MN 06/17/08 engr		M.HAHN		4/1/91					
F M06-0389 AGS 10/4/06 chr		M.HAHN		4/1/91					
G EX-N-011707 J.Z 2012-05-04 appd		M.HAHN		4/1/91					
sheet	revision	G	G						
index	sheet	1	2						

PRODUCT NO.	NO. OF POS.	DIM L	LEAD FREE OPTION
69146-X04	1 X 4	.398/10.11	NOTE 3,4
-X06	1 X 6	.598/15.19	
-X08	1 X 8	.798/20.27	
-X10	1 X 10	.998/25.35	
-X12	1 X 12	1.198/30.43	
-X14	1 X 14	1.398/35.51	
-X16	1 X 16	1.598/40.59	
-X18	1 X 18	1.798/45.67	
69146-X20	1 X 20	1.998/50.75	NOTE 3,4

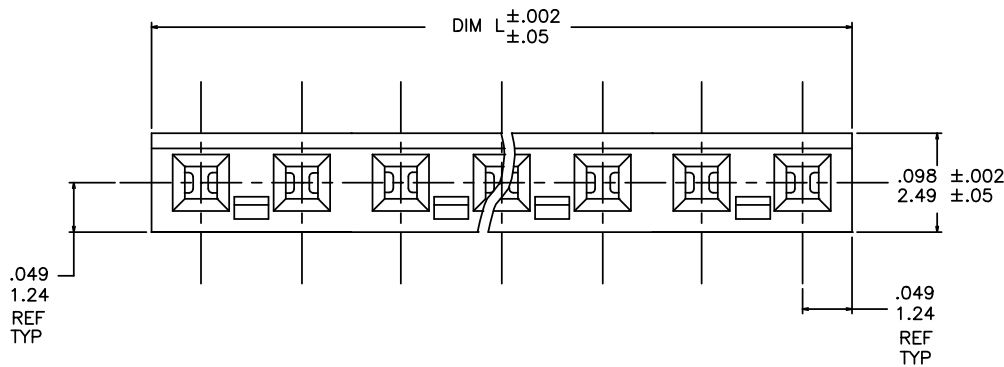
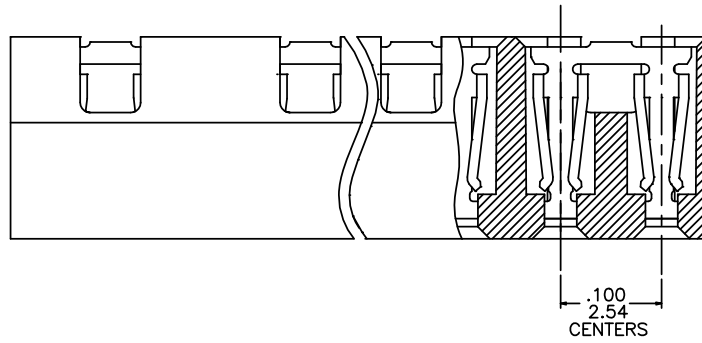
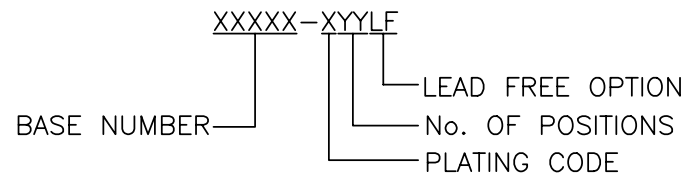

NOTES:

- MATERIAL; POLYESTER, FLAME RETARDANT PER UL-94-V0. COLOR - BLACK
- RECOMMENDED APPLICATION DATA:
 - ALL MATING PINS TO BE .025/.64 SQ.ON TRUE CENTER OF GIVEN TERMINAL SPACEING WITHIN .015/.38 DIA.
 - SUGGESTED MATING PIN LENGTH .160/4.06 MIN.
- ADD "LF" SUFFIX AT THE END OF PART NUMBER FOR LEAD FREE OPTION.
- THESE PRODUCTS MEET EUROPEAN UNION DIRECTIVES AND OTHER COUNTRY REGULATIONS AS DESCRIBED IN GS-22-008.
- THE PRODUCT IS NOT INTENDED TO BE EXPOSED TO A MANUFACTURING SOLDER PROCESS.
- "THIS PRODUCT HAS 100% TIN PLATING IN THE INTERFACE AND HAS NOT BEEN TESTED FOR WHISKERS GROWTH IN ALL INTERCONNECT ENVIRONMENTS."
- PRODUCT SPECIFICATION: BUS-12-071.

CONTACT PLATING:

- 1XX 15μ"/0.38μ Au OR GXT OVER 50μ"/1.27μ Ni
- 2XX 30μ"/0.76μ Au OR GXT OVER 50μ"/1.27μ Ni
- 3XXLF 100μ"/2.54μ Sn OVER 50μ"/1.27μ Ni (NOTE 6)
- ~~-4XX Au FLASH OVER 50μ"/1.27μ Ni in CONTACT AREA~~ OBSOLETE

mat'l. code		surface ISO 1302 ✓		tolerance ISO 406 ISO 1101		projection ⊕		product family JUMPER	
ltr ecn nopr date		tolerances unless otherwise specified		INCH/MM		title S. R. MULTI POSITION LOW PROFILE JUMPER ASS'Y			
G		angles		linear		scale 1:1		dwg no 69146	
		0°±2'		.XX±.01/.3 .XXX±.005/.13 .XXX±.0020/.05		FCJ		sheet 2 of 2 size A3	
		dr J. SHREINER 4/1/91		engr M.HAHN 4/1/91				type Product Customer Drawing	
		chr M.HAHN 4/1/91		appd M.HAHN 4/1/91					
sheet index		revision sheet							