



PNP Darlington Power Silicon Transistor

Qualified per MIL-PRF-19500/540

*Qualified Levels:
JAN, JANTX, and
JANTXV*

DESCRIPTION

This high speed PNP transistor is rated at 8 amps and is military qualified up to a JANTXV level. This TO-213AA isolated package features a 180 degree lead orientation.



**TO-213AA (TO-66)
Package**

Important: For the latest information, visit our website <http://www.microsemi.com>.

FEATURES

- JEDEC registered 2N6298 and 2N6299
- Hermetically sealed
- JAN, JANTX, and JANTXV qualifications are available per MIL-PRF-19500/540
- RoHS compliant versions available (commercial grade only)

APPLICATIONS / BENEFITS

- Convenient package
- Mechanically rugged
- Military, space and other high reliability applications

MAXIMUM RATINGS @ 25 °C unless otherwise stated

Parameters/Test Conditions	Symbol	Value	Unit
Junction and Storage Temperature	T _J and T _{STG}	-65 to +175	°C
Thermal Resistance Junction-to-Case	R _{θJC}	2.33	°C
Collector-Base Voltage	V _{CBO}	2N6298 2N6299	V
		-60 -80	
Collector-Emitter Voltage	V _{CEO}	2N6298 2N6299	V
		-60 -80	
Emitter-Base Voltage	V _{EBO}	-5	V
Continuous Operating Collector Current	I _C	-8	A
Base Current	I _B	-120	mA
Total Power Dissipation ⁽¹⁾	P _T	@ T _C = +25 °C	64
		@ T _C = +100 °C	32

NOTES: 1. Derate linearly at 0.428 W/°C above T_C > +25 °C.

MSC – Lawrence

6 Lake Street,
Lawrence, MA 01841
Tel: 1-800-446-1158 or
(978) 620-2600
Fax: (978) 689-0803

MSC – Ireland

Gort Road Business Park,
Ennis, Co. Clare, Ireland
Tel: +353 (0) 65 6840044
Fax: +353 (0) 65 6822298

Website:

www.microsemi.com

MECHANICAL and PACKAGING

- CASE: Hermetic, TO-213AA package. Nickel plate with nickel cap.
- TERMINALS: Solder dipped (Sn63/Pb37) over nickel plated alloy 52. RoHS compliant matte-tin plating is also available.
- MARKING: MSC, part number, date code, polarity symbol
- WEIGHT: Approximately 5.7 grams
- See [Package Dimensions](#) on last page.

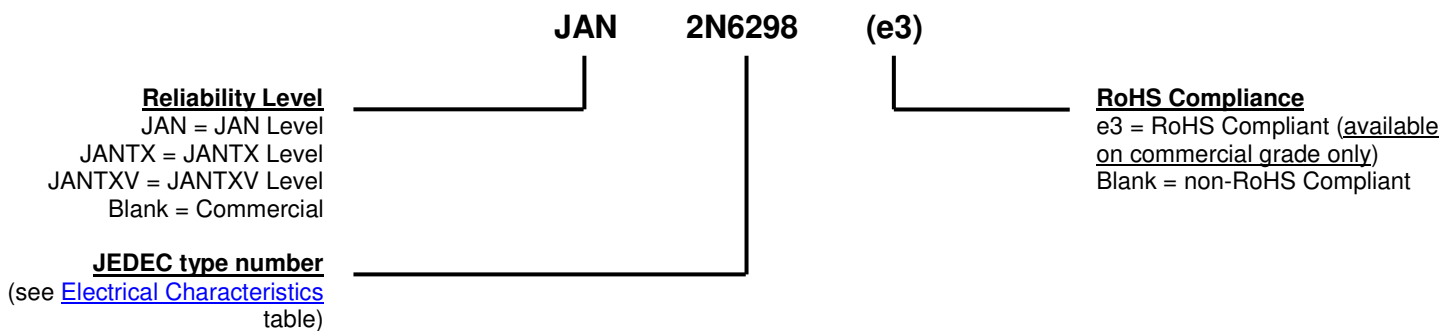
PART NOMENCLATURE

SYMBOLS & DEFINITIONS

Symbol	Definition
I_B	Base current: The value of the dc current into the base terminal.
I_C	Collector current: The value of the dc current into the collector terminal.
I_E	Emitter current: The value of the dc current into the emitter terminal.
T_C	Case temperature: The temperature measured at a specified location on the case of a device.
V_{CB}	Collector-base voltage: The dc voltage between the collector and the base.
V_{CBO}	Collector-base voltage, base open: The voltage between the collector and base terminals when the emitter terminal is open-circuited.
V_{CC}	Collector-supply voltage: The supply voltage applied to a circuit connected to the collector.
V_{CEO}	Collector-emitter voltage, base open: The voltage between the collector and the emitter terminals when the base terminal is open-circuited.
V_{EB}	Emitter-base voltage: The dc voltage between the emitter and the base.
V_{EBO}	Emitter-base voltage, collector open: The voltage between the emitter and base terminals with the collector terminal open-circuited.

ELECTRICAL CHARACTERISTICS @ 25 °C unless otherwise stated

Parameters / Test Conditions	Symbol	Min.	Max.	Unit
ON CHARACTERISTICS ⁽¹⁾				
Collector-Emitter Breakdown Voltage $I_C = -100 \text{ mA}$	2N6298 2N6299	$V_{(BR)CEO}$	-60 -80	V
Collector-Emitter Cutoff Current $V_{CE} = -60, V_{BE} = 1.5 \text{ V}$ $V_{CE} = -80, V_{BE} = 1.5 \text{ V}$	2N6298 2N6299	I_{CEX}	10	μA
Collector-Emitter Cutoff Current, Base Open $V_{CE} = -30 \text{ V}$ $V_{CE} = -40 \text{ V}$	2N6298 2N6299	I_{CEO}	-0.5	mA
Emitter-Base Cutoff Current $V_{EB} = -5 \text{ V}$		I_{EBO}	-2.0	mA
Forward Current Transfer Ratio $I_C = -1 \text{ A}, V_{CE} = -3 \text{ V}$ $I_C = -4 \text{ A}, V_{CE} = -3 \text{ V}$ $I_C = -8 \text{ A}, V_{CE} = -3 \text{ V}$		h_{FE}	500 750 100	18000
Collector-Emitter Saturation Voltage $I_C = -4.0 \text{ A}, I_B = -16 \text{ mA}$ $I_C = -8.0 \text{ A}, I_B = -80 \text{ mA}$		$V_{CE(sat)}$	-2.0	V
Base-Emitter Saturation Voltage $I_C = -8.0 \text{ A}, I_B = -80 \text{ mA}$		$V_{BE(sat)}$	-4.0	V

DYNAMIC CHARACTERISTICS

Parameters / Test Conditions	Symbol	Min.	Max.	Unit
Magnitude of Common Emitter Small-Signal Short-Circuit Forward Current Transfer Ratio $V_{CE} = -3.0 \text{ V}, I_C = -3.0 \text{ A}, f = 1 \text{ MHz}$	$ h_{fe} $	25	350	
Common Emitter Small-Signal Short-Circuit Forward Current Trans-Ratio $V_{CE} = -3 \text{ V}, I_C = -3 \text{ A}, f = 1 \text{ kHz}$	h_{fe}	300		
Output Capacitance $V_{CB} = -10 \text{ V}, I_E = 0 \text{ A}, 100 \text{ kHz} \leq f \leq 1 \text{ MHz}$	C_{obo}		200	pF

(1) Pulse Test: pulse width = 300 μs , duty cycle $\leq 2.0 \%$

ELECTRICAL CHARACTERISTICS @ $T_C = 25\text{ }^\circ\text{C}$ unless otherwise noted. (continued)**SWITCHING CHARACTERISTICS**

Parameters / Test Conditions	Symbol	Min.	Max.	Unit
Turn-On time $V_{CC} = -30\text{ V}$, $I_C = -4\text{ A}$, $I_{B1} = -16\text{ mA}$	t_{on}		2.0	μs
Turn-Off time $V_{CC} = -30\text{ V}$, $I_C = -4\text{ A}$, $I_{B1} = -16\text{ mA}$	t_{off}		8.0	μs

SAFE OPERATING AREA (See figures 1 and 2 and [MIL-STD-750, Test Method 3053](#))**DC Tests** $T_C = 25\text{ }^\circ\text{C} +10\text{ }^\circ\text{C}$, $t = 1\text{ second}$, 1 Cycle**Test 1** $V_{CE} = -8\text{ V}$, $I_C = -8\text{ A}$ **Test 2** $V_{CE} = -20\text{ V}$, $I_C = -2.0\text{ A}$ **Test 3** $V_{CE} = -60\text{ V}$, $I_C = -100\text{ mA}$ (2N6298) $V_{CE} = -80\text{ V}$, $I_C = -100\text{ mA}$ (2N6299)

SAFE OPERATING AREA

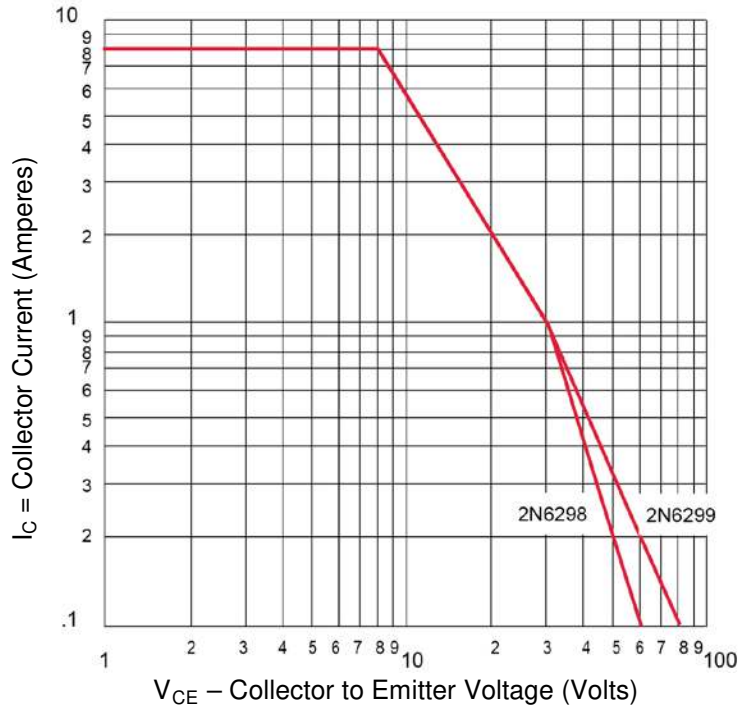
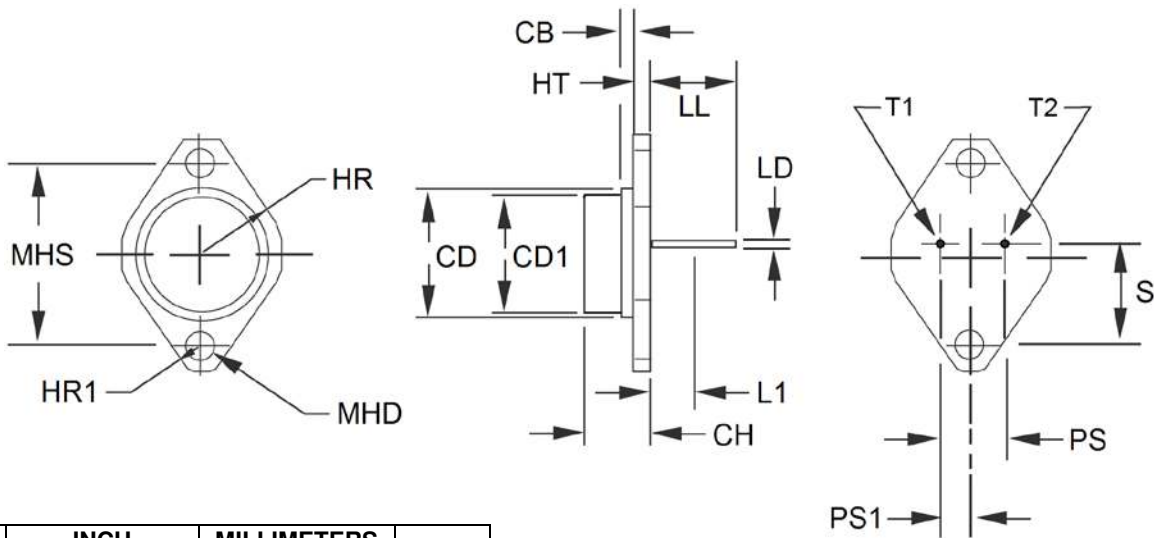

FIGURE 1
Maximum Safe Operating Area (dc)



FIGURE 2
Safe Operating Area for switching between saturation and cutoff (unclamped inductive load)

PACKAGE DIMENSIONS



DIM	INCH		MILLIMETERS		Notes
	MIN	MAX	MIN	MAX	
CB	0.470	0.500	11.94	12.70	
CD	-	0.620	-	15.76	
CH	0.250	0.340	6.35	8.64	
HR	-	0.350	-	8.89	
HT	0.050	0.075	1.27	1.91	
HR1	0.115	0.145	2.92	3.68	4
LD	0.028	0.034	0.71	0.86	4, 6
LL	0.360	0.500	9.14	12.70	
L1	-	0.050	-	1.27	6
MHD	0.142	0.152	3.61	3.86	4
MHS	0.958	0.962	24.33	24.43	
PS	0.190	0.210	4.83	5.33	3
PS1	0.093	0.107	2.36	2.73	3
S	0.570	0.590	14.48	14.99	
T1	Base				
T2	Emitter				
Case	Collector				

NOTES:

1. Dimensions are in inches.
2. Millimeters are given for information only.
3. These dimensions should be measured at points 0.050 inch (1.27 mm) +0.005 inch (0.13 mm) -0.000 inch (0.00 mm) below seating plane. When gauge is not used, measurement will be made at the seating plane.
4. Two places.
5. The seating plane of the header shall be flat within 0.001 inch (0.03 mm) concave to .004 inch (0.10 mm) convex inside a .930 inch (23.62 mm) diameter circle on the center of the header and flat within .001 inch (0.03 mm) concave to .006 inch (0.15 mm) convex overall.
6. Lead diameter shall not exceed twice LD within L1.
7. Lead number 1 is the emitter, lead 2 is the base, case is the collector.
8. In accordance with ASME Y14.5M, diameters are equivalent to Φx symbology.

SCHEMATIC

