

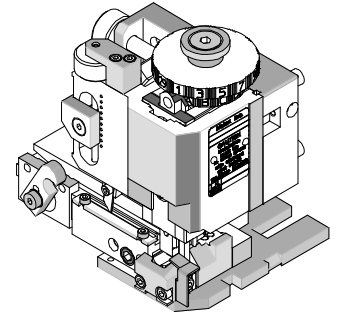

# FineAdjust Applicator Specification Sheet Order Part No. 63866-2000



## FEATURES

- Directly adapts to most automatic wire processing machines
- Quick punch removal with the push of a button for fast and easy tooling change
- Applicator designed to industry standard mounting and shut height 135.80mm (5.346")
- Quick set-up time; plus the crimp height, track and feed adjustments can be set without removing the applicator from the press
- Fine adjustment allows users to achieve target with little effort by adjusting in increments of .015mm (.0006") for conductor crimp height and .063mm (.0025") for insulation height
- Independent adjustment rings allow users to quickly adjust the conductor or insulation crimp height without affecting each other

## SCOPE

Products: KK® 3.96mm (.156") Centers Female Terminals 18-20 AWG.

Terminal Series No.	Terminal Order No.	Wire Size		Insulation Diameter		Strip Length	
		AWG	mm <sup>2</sup>	mm	In.	mm	In.
45570	45570-3000	18-20	0.82-0.52	1.70-2.85	.067-.112	2.40-3.40	.094-.134
	45570-3002	18-20	0.82-0.52	1.70-2.85	.067-.112	2.40-3.40	.094-.134
	45570-3004	18-20	0.82-0.52	1.70-2.85	.067-.112	2.40-3.40	.094-.134

## DEFINITION OF TERMS

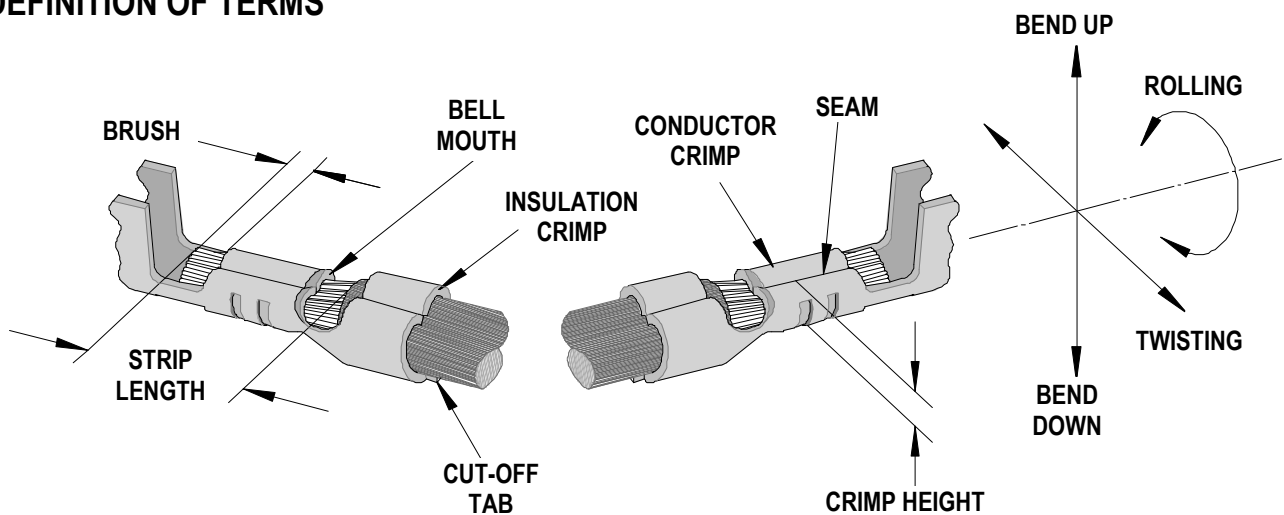

The above terminal drawing is a generic terminal representation. It is not an image of a terminal listed in the scope.

### CRIMP SPECIFICATION

Terminal Series No.	Bell mouth		Cut-off Tab Maximum		Conductor Brush	
	mm	In.	mm	In.	mm	In.
45570	0.20-0.50	.008-.020	0.40	.015	0.30-0.90	.012-.035

Terminal Series No.	Bend up	Bend down	Twist	Roll	Punch Width (Ref)				Seam Seam shall not be open and no wire allowed out of the crimping area
	Degree		Degree		Conductor		Insulation		
					mm	In	mm	In	
45570	5	1	4	8	1.80	.071	3.00	.118	

After crimping, the conductor profile should measure the following.

Terminal Series No.	Wire Size		Crimp Height		Pull Force Minimum	
	AWG	mm <sup>2</sup>	mm	In.	N	Lb.
45570	18	0.82	1.20-1.30	.047-.051	89.0	20.00
	20	0.52	1.10-1.20	.043-.047	57.9	13.00

Pull Force should be measured with no influence from the insulation crimp.

The above specifications are guidelines to an optimum crimp.

**PARTS LIST**

<b>FineAdjust Applicator 63866-2000</b>				
<b>Item</b>	<b>Order No.</b>	<b>Engineering No.</b>	<b>Description</b>	<b>Quantity</b>
<b>Perishable Tooling</b>				
	63866-2070	63866-2070	Tool Kit (All "Y" Items)	REF
1	63444-1820	63444-1820	Conductor Punch	1 Y
2	63445-1836	63445-1836	Conductor Anvil	1 Y
3	63446-3002	63446-3002	Insulation Punch	1 Y
4	63445-3017	63445-3017	Insulation Anvil	1 Y
5	63443-0002	63443-0002	Cut-Off Plunger	1 Y
6	63443-0005	63443-0005	Front Cut-Off Plunger	1 Y
7	63443-0012	63443-0012	Front Plunger Retainer	1 Y
8	63443-1002	63443-1002	Rear Plunger Retainer	1 Y
9	63443-1403	63443-1403	Cut-off Die Blade	1 Y
<b>Other Components</b>				
10	11-18-4083	60707-8	Feed Guide	1
11	11-24-1067	4996-4	Cut-Off Plunger Spring	2
12	63443-0025	63443-0025	Key	1
13	63443-0091	63443-0091	Wire Stop	1
14	63443-1741	63443-1741	17.00mm Height Spacer	1
15	63443-2204	63443-2204	4.00mm Spacer	1
16	63443-2310	63443-2310	3.50mm Spacer	1
17	63443-2802	63443-2802	Front Plunger Striker	1
18	63443-2907	63443-2907	Wire Hold Down Plunger	1
19	63443-3060	63443-3060	Rear Plunger Striker	1
20	63443-6117	63443-6117	Rear Cover	1
21	63600-0021	63600-0021	Compression Spring	1
<b>Frame</b>				
22	63800-4901	63800-4901	Top	1
23	63801-3281	63801-3281	Base	1
24	63801-4650	63801-4650	Track	1
<b>Hardware</b>				
25	N/A	N/A	M3 by 6 Long SHCS	2**
26	N/A	N/A	M3 by 6 Long FHCS	1**
27	N/A	N/A	M4 by 6 Long SHCS	1**
28	N/A	N/A	M4 by 10 Long BHCS	2**
29	N/A	N/A	M4 by 12 Long BHCS	2**
30	N/A	N/A	M4 by 30 Long SHCS	1**
31	N/A	N/A	M4 by 50 Long SHCS	1**
32	N/A	N/A	M5 by 12 Long SHCS	1**
33	N/A	N/A	#10-32 by 3/8" Long Flat point SSS	1**
34	N/A	N/A	#10-32 Hex Jam Nut	1**
** Available from an industrial supply company such as MSC (1-800-645-7270).				

# Assembly Drawing

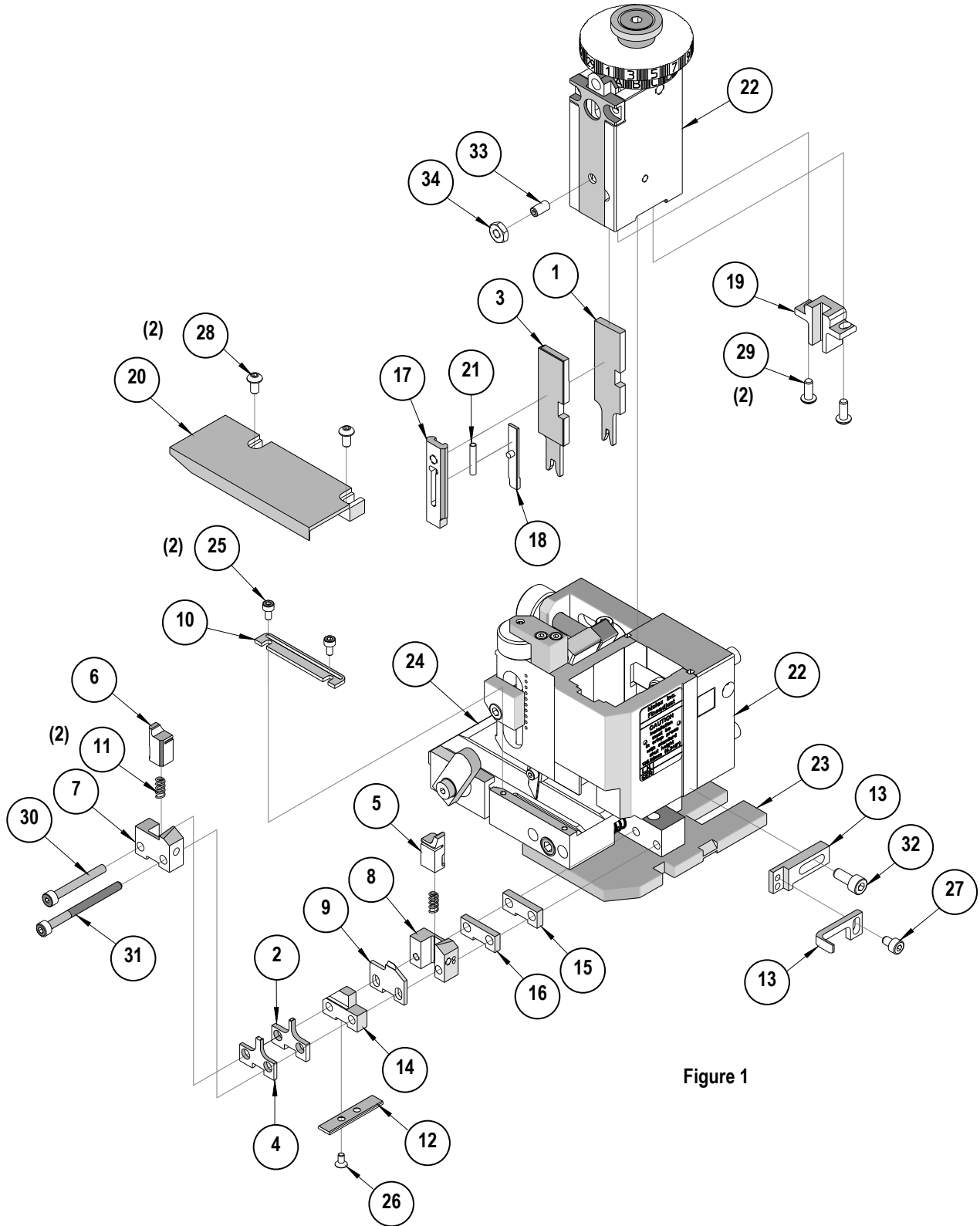

## NOTES

1. Molex recommends an extra perishable tooling kit be maintained at your facility.
2. Verify tooling alignment by manually cycling the press and Applicator before crimping under power. Check that all screws are tight.
3. Slugs, Terminals, Dirt and Oil should be kept clear of work area.
4. Wear safety glasses at all times.
5. For recommended maintenance refer to the FineAdjust Manual.

**CAUTION:** This applicator should only be used in a press with a shut height of 135.8mm (5.346"). Tooling damage could result at a lower setting.

**CAUTION:** To prevent injury never operate this Applicator without the guards supplied with the press or wire-processing machine in place. Reference the press or wire processing manufacturer's instruction manual.

**CAUTION:** Molex crimp specifications are valid only when used with Molex terminals, applicators and tooling.

**Americas Headquarters**  
Lisle, Illinois 60532 U.S.A.  
1-800-78MOLEX  
amerinfo@molex.com

**Far East North Headquarters**  
Yamato, Kanagawa, Japan  
81-462-65-2324  
feninfo@molex.com

**Far East South Headquarters**  
Jurong, Singapore  
65-6-268-6868  
fesinfo@molex.com

**European Headquarters**  
Munich, Germany  
49-89-413092-0  
eurinfo@molex.com

**Corporate Headquarters**  
2222 Wellington Ct.  
Lisle, IL 60532 U.S.A.  
630-969-4550  
Fax: 630-969-1352

Visit our Web site at <http://www.molex.com>