

Mechanical Dimensions: Inches [mm]

Tolerances ± 0.012 [0.5] Unless Otherwise Specified

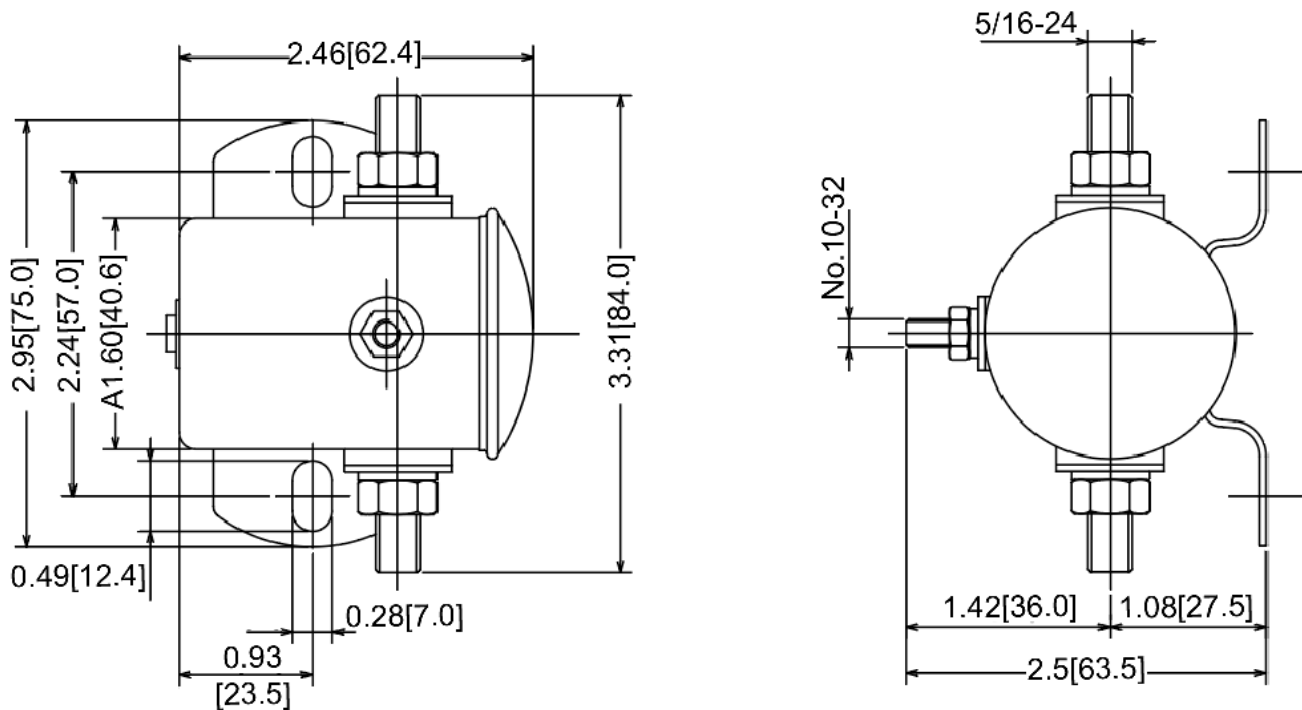

Circuit Diagram

Continuous Duty. Insulated base

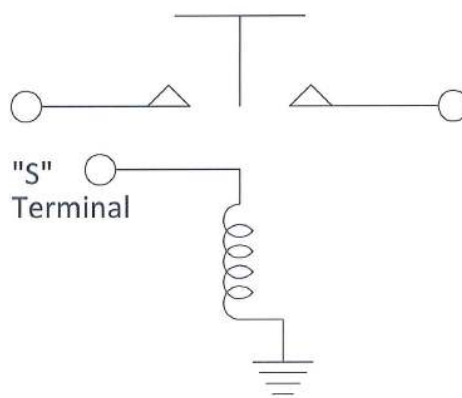

Electrical Specifications

Continuous Rating	12V 80A
Coil Resistance	56 ± 2 Ohms
Operating Voltage	<19VDC
Release Voltage	>2.4VDC

Material Specifications

Iron plates with trivalent zinc body
Copper terminals
Load terminals 5/16" - 24 Thread, Coil terminals No.10-32 Thread
Bracket Mounting Holes: 9/32" x 3/4", 2 13/64" on centers.
Straight bracket

Rev	Date of issue	Revision Notes	Designed	Approved
B	03-09-2020	Initial Drawing	RC	OF