

# MHP-TAM Series Breakers (Thermal Cutoff Devices)

MHP with Thermal Activation



## Description

The rapidly expanding market for ultra-thin portable electronic devices, such as media tablets and ultra-thin PCs, has created demand for very thin, low-profile, lightweight and high-capacity Lithium Polymer (LiP) and prismatic cells.

A new MHP (Metal Hybrid PPTC) device, the MHP-TAM device, offers a 9V<sub>DC</sub> rating and a higher current rating than typical battery strap devices. This helps them meet the battery safety requirements of higher-capacity LiP and prismatic batteries found in the latest tablet and ultra-thin computing products. Hybrid MHP technology connects a bimetal protector in parallel with a PPTC (polymeric positive temperature coefficient) device. The resulting MHP-TAM (Thermal Activation) series helps provide resettable overtemperature and overcurrent protection, while utilizing the PPTC device to act as a heater and to help keep the bimetal latched until the fault is removed.

## Circuit Diagram

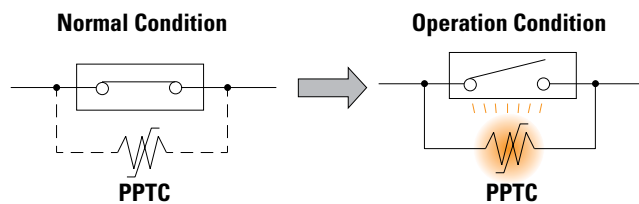

## Agency Approvals

Agency	Agency File Number
	E349829
	TAM15: US-29471-UL TAM6: US-29473-UL

## Features

- 9V<sub>DC</sub> rating
- Overtemperature and overcurrent protection for Lithium (Ion) Polymer and Prismatic cells
- Two levels of current carrying capacity:  
Low current (nominal 6A hold current @25°C)  
High current (nominal 15A hold current @25°C)
- Multiple activation temperature ratings (72°C, 77°C, 82°C, 85°C, 90°C)
- Compact size (L: 5.8mm x W: 3.85mm x H: 1.15mm Max.) allows for ultra-thin battery pack designs
- Evaluated to UL 60730-1 and UL 60730-2-9, CAN/CSA E60730-1, CAN/CSA E730-2-9 and IEC 60730-1 and IEC 60730-2-9

## Benefits

- Capable of handling the higher voltages and battery discharge rates found in high-capacity LiP and prismatic cell applications
- Helps provide resettable overtemperature protection in high-capacity LiP and prismatic cell applications

## Additional Information



Resources



Accessories



Samples

## Applications

Battery cell protection for high-capacity Lithium Polymer and prismatic cells used in:

- Notebook PCs
- Ultra-book
- Tablets
- Smart phones
- Battery-powered portable electronic devices

# MHP-TAM Series Breakers (Thermal Cutoff Devices)

## MHP with Thermal Activation

### Electrical Characteristics for MHP-TAM15 Series

Part Description	Ordering Part Number	Rating [°C] Nominal	Operation Temperature [°C]		Reset Temperature [°C]		Reference Resistance [mohms] 25°C	
			Min	Max	Min	ΔT	Typ	Max
MHP-TAM15-9-72	RF4374-000	72	67	77	≥40	≥7	2.5	5
MHP-TAM15-9-72N	RF4849-000	72	67	77	≥40	≥7	2.5	5
MHP-TAM15-9-77	RF4375-000	77	72	82	≥40	≥10	2.5	5
MHP-TAM15-9-77N	RF4689-000	77	72	82	≥40	≥10	2.5	5
MHP-TAM15-9-82	RF4376-000	82	77	87	≥40	≥10	2.5	5
MHP-TAM15-9-82N	RF4866-000	82	77	87	≥40	≥10	2.5	5
MHP-TAM15-9-85	RF4377-000	85	80	90	≥40	≥10	2.5	5
MHP-TAM15-9-85N	RF4744-000	85	80	90	≥40	≥10	2.5	5
MHP-TAM15-9-90	RF4378-000	90	85	95	≥40	≥10	2.5	5
MHP-TAM15-9-90N	RF4867-000	90	85	95	≥40	≥10	2.5	5

**Notes**

1. Maximum breaking current  $5V_{DC} / 80A$  (100 cycles)
2. Contact Rating  $9V_{DC} / 25A$  (6000 cycles)

### Electrical Characteristics for MHP-TAM6 Series

Part Description	Ordering Part Number	Rating [°C] Nominal	Operation Temperature [°C]		Reset Temperature [°C]		Reference Resistance [mohms] 25°C	
			Min	Max	Min	ΔT	Typ	Max
MHP-TAM6-9-72	RF4370-000	72	67	77	≥40	≥7	10	15
MHP-TAM6-9-77	RF4371-000	77	72	82	≥40	≥10	10	15
MHP-TAM6-9-82	RF4372-000	82	77	87	≥40	≥10	10	15
MHP-TAM6-9-85	RF4373-000	85	80	90	≥40	≥10	10	15

**Notes**

1. Maximum breaking current  $5V_{DC} / 40A$  (100 cycles)
2. Contact Rating  $9V_{DC} / 12A$  (6000 cycles)
3. ΔT is the minimum temperature differential between the actual operation temperature of the device and the reset temperature

### Dimensions in Millimeters and Mechanical Characteristics

Unit	A		B	C		D		C	
	Min	Max	Max	Min	Max	Min	Max	Min	Max
mm:	10.9	11.4	1.15	3.75	3.85	2.6	2.8	2.6	2.8

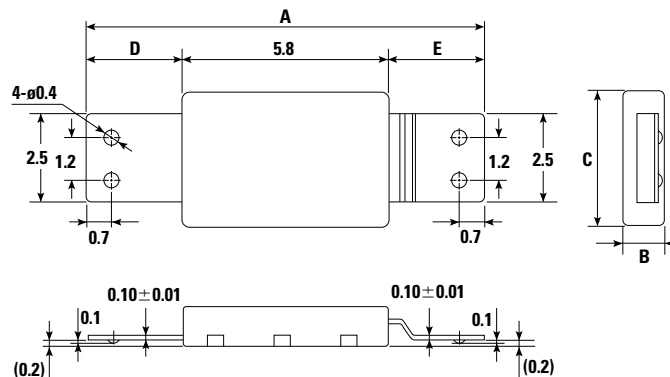

# MHP-TAM Series Breakers (Thermal Cutoff Devices)

## MHP with Thermal Activation

### Hold Current vs. Temperature Curves (Typical)

Figure M1

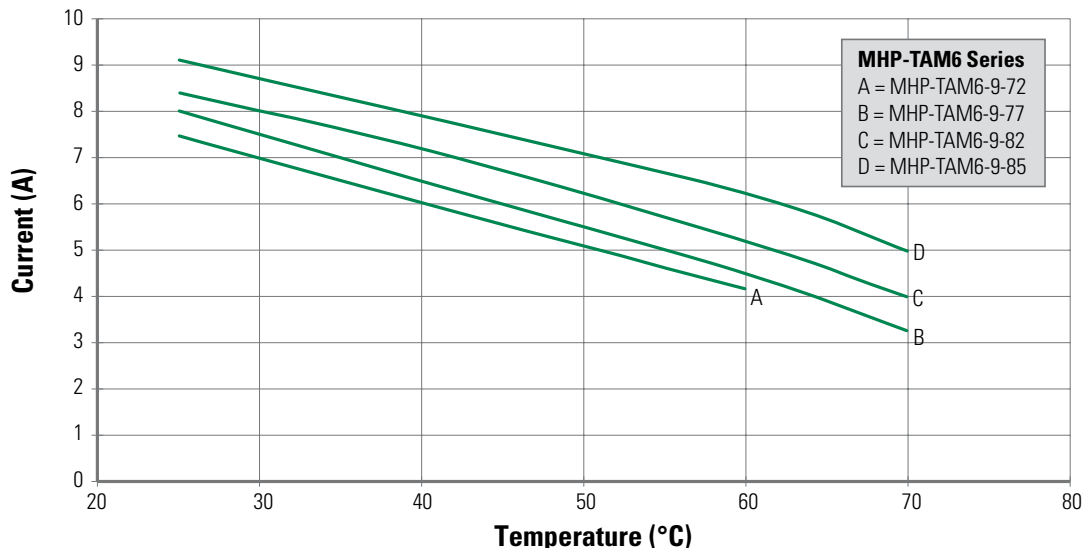
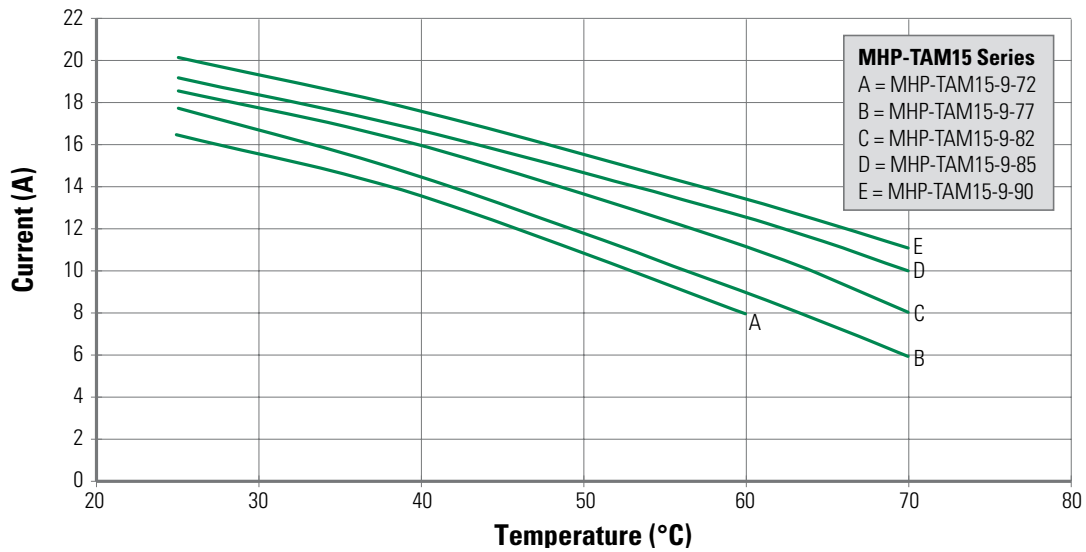

Figure M2



# MHP-TAM Series Breakers (Thermal Cutoff Devices)

## MHP with Thermal Activation

### RoHS and Halogen-Free Compliance

RoHS Compliant  
Halogen Free per IEC 61249-2-21

### Part Naming System

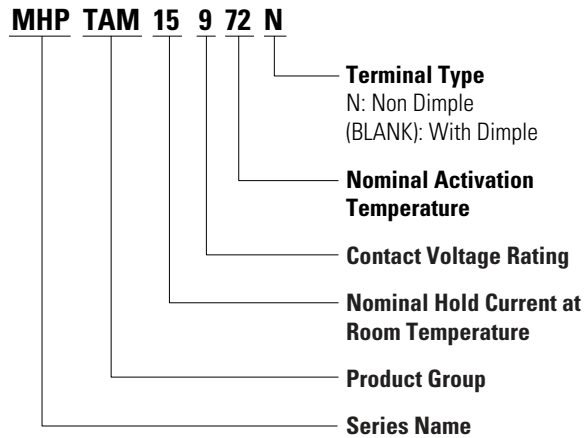

### Application Environment

The device is intended to be used for applications which are common for general electronic devices. Usage in any of the special environments or conditions as listed below may adversely impact the device performance and therefore users should carefully consider conditions of use of the end product and the potential impact on reliability or performance when incorporating this device into any design to carefully examine the actual performance and reliability of the device.

- Environment where the devices are exposed to water, oil, chemical solutions, and/or organic solvents.
- Installation in an area close to a heat source or adjacent to or near flammable objects such as plastic wires.
- Environment in which the device is constrained by pressure, sealing or resin coating.
- Environment where water condenses on the device.
- Environment with salt air or with corrosive gas such as CL<sub>2</sub>, H<sub>2</sub>S, NH<sub>3</sub>, SO<sub>2</sub>, and NO<sub>x</sub>.
- Environment with grit and dust and/or under direct sunlight.
- Environment outside of recommended operating temperature.

### Precautions for Rating

- a. The power supply voltage must be less than or equal to the rated voltage of the device. Operation above the voltage rating may result in device damage, smoke or flame.
- b. Designs must be selected in such a manner that the device hold current is higher than the normal current value in the circuit. Selecting device hold current that is too low for the application may interrupt the circuit under normal usage conditions.
- c. This product should not be used in an application where the maximum short circuit current available exceeds the rated maximum breaking current of the product.
- d. The devices are intended for protection against damage caused by occasional over current or over temperature fault conditions and should not be used when repeated fault conditions or prolonged trip events are anticipated.
- e. The devices may not perform as specified if mechanical pressure is added while the device is in the tripped state or exposed to temperature conditions over 100°C or in temperature conditions under -30°C.

### Packaging and Marking Information

	MHP-TAM 15 Series	MHP-TAM 6 Series
<b>Bag Quantity</b>	1,000	1,000
<b>Standard Package</b>	20,000	20,000
<b>Part Marketing</b>	Lot ID#, Control# & Co. Logo, Product #	Lot ID#, Control# & Co. Logo, Product #

### Ordering Information

	1,000	pieces
<b>Bag</b>		
<b>Box</b>	20,000	pieces

# MHP-TAM Series Breakers (Thermal Cutoff Devices)

## MHP with Thermal Activation

### Precautions for Handling

The device is composed of plastic parts, please do not clamp or dent the housing with a tool as this might cause a resistance increase and product damage.

When welding product terminals or mounting the breaker on a battery (cell), please be careful not to apply excessive bending, twisting or force on the product and terminals. The excessive stress might cause a resistance increase or product damage.

Please refer to following cautions:

1. Do not apply more than 10N bend force to product. (Fig. M3)
2. Do not apply more than 1.5cN/m twist torque to the product. (Fig. M4)
3. Do not apply more than 20N deflection force to product. (Fig. M5)
4. Do not apply more than 2N force to the terminals. (Fig. M6)
5. Do not apply more than 0.6cN/m twisting torque to the terminals. (Fig. M7)
6. Do not bend the terminal base more than 45° when the product is mounted in a fixed position. (Fig. M8)

Product terminals can be welded using direct welding and series welding methods. In either case, please use a suitable jig so that the device will not be subjected to the stress conditions listed above.

Pull strength and detach strength of the terminal welds are per user requirements. However, if the welding is controlled by resistance, the measurement should be made as close as possible to the weld point by a "4-point clip method" using milliohm meter to ensure accuracy.

Avoid putting stress on the device, as listed above, when a jig, fitting or additional welding process is used. Please reconfirm the resistance value whenever a new process is added.

