

THIS DRAWING IS UNPUBLISHED. RELEASED FOR PUBLICATION  
 © COPYRIGHT BY TYCO ELECTRONICS CORPORATION. ALL RIGHTS RESERVED.

DESIGNED FOR USE WITH .141 DIA S.R. CABLE	
CABLE ENTRY DIAMETER MINIMUM	
CONTACT	.039
HOUSING	.144

REVISIONS				DATE	DWN	APVD
LOC	DIST	P	LTR	DESCRIPTION		
-	-	B		REV PER ECO 07-004710	3/14/2007	DW KW

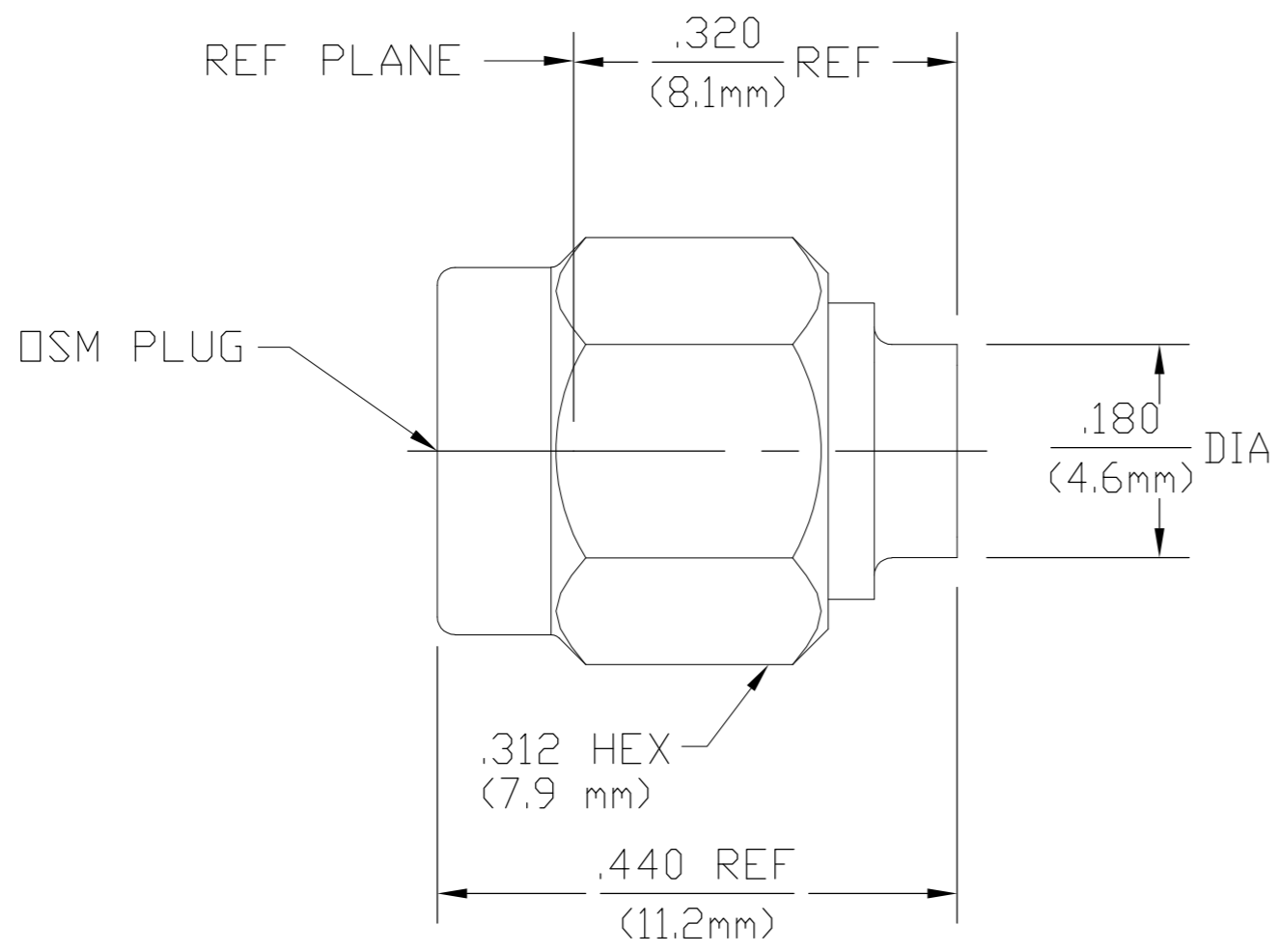

1050525-1  
 PART NUMBER

ELECTRICAL	MECHANICAL	ENVIRONMENTAL
Nominal Impedance (Ohms) 50	Interface Dimensions MIL-STD-348, Fig. 310.1	TEMPERATURE RATING -65°C TO 105°C
Frequency Range (GHz) DC to 18.0	Recommended Mating Torque 7 to 10 in-LBs	Vibration MIL-STD-202, Method 204, Condition D
Volt Rating (VRMS MAX) @ Sea Level 500	Mating Characteristics: Insertion (MAX Lbs) N/A	Shock MIL-STD-202, Method 213, Condition I
VSWR 1.05 + .008f(GHz)	Withdrawal (MIN Oz) N/A	Thermal Shock MIL-STD-202, Method 107, Condition B, EXCEPT HIGH TEMP 115°C
Insertion Loss (dB MAX) .03 √f(GHz)	Force to Engage and Disengage (In/Lbs MAX) 2.0	Moisture Resistance MIL-STD-202, Method 106,
RF Leakage (dB MIN) -(90-f(GHz))	Center Contact Captivation Axial (Lbs) N/A	Corrosion - MIL-STD-202, Method 101, Condition B, 5% salt spray
Corona, 70,000 Ft (VRMS MIN) 375	Cable Retention Axial Force (Lbs) 60	
Dielectric Withstanding Voltage (VRMS MIN) @ Sea Level 1000	Torque (In/Oz) 55	
Contact Resistance (Milliohms MAX) Center Contact 3.0	Weight (Grams) T.B.D.	
Outer Contact 2.0		
Cable to Housing 0.5		
RF High Potential @ Sea Level (VRMS MIN @ 5 MHz) 1000		
I.R.(Megohms MIN) 5,000		

COMPONENT	MATERIAL	FINISH
HOUSING	STAINLESS STEEL PER ASTM-A484 AND ASTM-A582, TYPE 303	GOLD PLATE PER MIL-G-45204 OVER NICKEL PLATE PER QQ-N-290
COUPLING NUT	STAINLESS STEEL PER ASTM-A484 AND ASTM-A582, TYPE 303	PASSIVATE PER ASTM-A-380
DIELECTRIC	TFE FLUOROCARBON PER ASTM-D-1457	N/A
CENTER CONTACT	BERYLLIUM COPPER PER ASTM B 196, ALLOY C17300, CONDITION H OR BRASS PER ASTM-B-16	GOLD PLATE PER MIL-G-45204 OVER COPPER PLATE PER MIL-C-14550
RETAINING RING	BERYLLIUM COPPER PER ASTM B 194, ALLOY C17200, CONDITION H	N/A
GASKET	SILICONE RUBBER PER ZZ-R-765	N/A

THIS DRAWING IS A CONTROLLED DOCUMENT.

DWN JPD 8/31/76	 Tyco Electronics Corporation Harrisburg, PA 17105-3608
CHK RNF 9/7/76	
APVD RNF 9/7/76	
PRODUCT SPEC	
APPLICATION SPEC	NAME OSM STRAIGHT CABLE PLUG DIRECT SOLDER ATTACHMENT
WEIGHT -	SIZE A2 CAGE CODE 00779 DRAWING NO C=1050525 RESTRICTED TO -
CUSTOMER DRAWING	SCALE 5:1 SHEET 1 of 1 REV B