

PART NUMBER	REVISION	DESCRIPTION	FEED TYPE
2151468-1	P	FINE CRIMP HEIGHT ADJUST	MECHANICAL
2151468-2	P	FINE CRIMP HEIGHT ADJUST	PNEUMATIC
7-2151468-1	P	MECHANICAL AND CRIMP TOOLING KIT	MECHANICAL
7-2151468-2	P	PNEUMATIC AND CRIMP TOOLING KIT	PNEUMATIC
7-2151468-7	L	CRIMP TOOLING KIT	-

ATLANTIC VERSION TERMINATOR INTERFACE ADAPTER



APPLICATOR DATA		
CRIMP	SIZE	TYPE
WIRE	1.78 mm [.070]	F
INSUL	2.29 mm [.090]	O

APPLICATOR INSTRUCTIONS 408-35042

TERMINAL DATA: TE TERMINAL		TE CRIMP SPECIFICATION	
TERMINAL NAME: MCON-1.2 CB			
WIRE STRIP LENGTH		INSULATION DIAMETER RANGE	
3.00-3.60 mm [.118-.142 IN]		Ø 1.60-2.40 mm [.063-.094 IN]	
TERMINAL APPLICATION SPECIFICATION	114-18464	-	-
TERMINALS APPLIED			
TE TERMINAL	TE TERMINAL	TE TERMINAL	TE TERMINAL
1452503-1	1452503-2	1452503-3	

TERMINAL DATA: TE TERMINAL		TE CRIMP SPECIFICATION	
TERMINAL NAME: MCON-1.2 CB			
WIRE STRIP LENGTH		INSULATION DIAMETER RANGE	
3.00-3.60 mm [.118-.142 IN]		Ø 1.60-2.40 mm [.063-.094 IN]	
TERMINAL APPLICATION SPECIFICATION	114-18464	-	-
TERMINALS APPLIED			
TE TERMINAL	TE TERMINAL	TE TERMINAL	TE TERMINAL
1718352-1	1718352-2	1718352-3	

WIRE SIZE	CRIMP HEIGHT mm [INCH]	CRIMP HEIGHT REFERENCE SETTING
1.50mm2	1.36+/-0.05 [.054+/- .002]	3.3
16 AWG	1.31+/-0.05 [.052+/- .002]	3.8
1.00mm2	1.18+/-0.05 [.046+/- .002]	5.2
18 AWG	1.11+/-0.05 [.044+/- .002]	6.0

WIRE SIZE	CRIMP HEIGHT mm [INCH]	CRIMP HEIGHT REFERENCE SETTING
1.50mm2	1.28+/-0.05 [.050+/- .002]	4.2
1.00mm2	1.10+/-0.05 [.043+/- .002]	6.1

- RECOMMENDED SPARE PARTS
 - REFER TO SUPPLIED INSTRUCTION SHEET FOR CLEANING, LUBRICATION AND STORAGE OF APPLICATOR.
 - APPLY PART NUMBER 2-23419-6 LOCTITE TO THREADS OF ITEM 242.
 - CRIMP HEIGHT REFERENCE SETTING WAS THE SETTING USED WHEN THE APPLICATOR WAS QUALIFIED AT THE FACTORY. ADJUSTMENT MAY BE NECESSARY WHEN RUNNING APPLICATOR IN THE FIELD.
 - TERMINAL LUBRICANT IS RECOMMENDED.
6. UNLESS SPECIFIED OTHERWISE TORQUE VALUES SHALL BE USED PER DOCUMENT, 101-35000.

***WARNING**
ON INSTALLATION, SET WIRE DISC TO CRIMP HEIGHT REFERENCE SETTING FOR LARGEST WIRE SIZE. CRIMP HEIGHT REFERENCE SETTINGS GREATER THAN THE VALUE SHOWN MAY CAUSE DAMAGE TO THE CRIMP TOOLING, REFER TO THE INSTRUCTION SHEET FOR PROPER SETUP AND ADJUSTMENTS.

LOC	DIST	REVISIONS					
A	66	P	LTN	DESCRIPTION	DATE	OWN	APVD
		N		ECR-20-014320	09OCT2020	FZ	TE
		P		ECR-21-111678	26AUG2021	JWC	GB
		P1		ECR-22-132154	11MAR2022	FZ	JH
		P2		ECR-22-149365	15AUG2022	FZ	YY

-	1	-	1	-	2119641-1	FEED CAM, AIR FEED	248
-	1	1	1	1	2119082-8	CAM, SNAIL, INSULATION ADJUSTMENT	244
-	1	1	1	1	2079764-1	WASHER, WAVE SPRING, CREST-TO-CREST	243
-	1	1	1	1	2119083-1	RETAINER, INSULATION DIAL	242
-	1	1	1	1	7-18023-7	SCR, SKT HD CAP M3 X 4.0	241
-	-	1	-	1	2119580-1	MECHANICAL FEED ASSEMBLY	239
-	1	-	1	-	2844940-1	AIR FEED MODULE	238
-	REF	REF	REF	REF	994970-2	COUNTER, MAGNETIC	164
-	1	1	1	1	1-18028-2	WASHER, FLAT, REG M4	119
-	1	1	1	1	2119955-1	ASSY, LUBRICATOR, SIDE FEED	113
-	1	1	1	1	2844908-1	SCREW, LOCKING	99
-	1	1	1	1	2844907-1	POST, LOCKING	98
-	1	1	1	1	455888-4	SPACER, CRIMPER	82
-	1	1	1	1	22278-8	SPRING, COMPRESSION	77
-	1	1	1	1	854769-4	HOLDER, INS	74
-	1	1	1	1	1803607-3	DOCUMENTATION PACKAGE	71
-	1	1	1	1	2119791-9	DEPRESSOR, WIRE	70
-	1	1	1	1	2119740-1	TAG IDENTIFICATION	67
-	2	2	2	2	2168078-1	SCREW, DRIVE, RH, RoHS, 2 x .188	66
-	1	1	1	1	2168083-2	SCR, SKT HD CAP, RoHS, M4 X 8.0	60
-	1	1	1	1	5-18022-5	SCR, HEX HD CAP, M4 X 6.0	59
-	1	1	1	1	21028-2	PIN, SLOTTED SPRING .062 X .250	58
-	1	1	1	1	1338685-1	PAWL, FEED	56
-	4	4	4	4	2168083-3	SCR, SKT HD CAP, RoHS, M4 X 12.0	54
-	2	2	2	2	1-2168083-0	SCR, SKT HD CAP, RoHS, M4 X 10	53
-	1	2	1	2	18023-9	SCR, SKT HD CAP M4 X 6.0	49
-	-	1	-	1	2119652-1	FEED CAM, PRE FEED	48
-	-	1	-	1	2119653-1	FEED CAM, POST FEED	47
-	1	1	1	1	1803583-9	APPLICATOR BASIC ASSEMBLY, SF	46
-	1	1	1	1	1803515-1	RAM ASSEMBLY, SF ATLANTIC	44
-	1	1	1	1	1803602-1	SCR, BHSC, RoHS (M8 X 25)	41
-	1	1	1	1	1-1752356-8	SUPPORT, TERMINAL	34
-	2	2	2	2	2079383-5	SCR, BHSC, RoHS (M4 X 20)	33
-	2	2	2	2	2-2844962-6	SPACER, CYLINDRICAL, STRIP GUIDE	30
-	1	1	1	1	2844992-2	ASSEMBLY, STRIP GUIDE	29
-	1	1	1	1	1320928-2	STRIP GUIDE	24
-	1	1	1	1	2168083-2	SCR, SKT HD CAP, RoHS, M4 X 8.0	21
-	3	3	3	3	1-18028-2	WASHER, FLAT, REG M4	20
-	1	1	1	1	2119533-1	STRIPPER, SIDE FEED	19
-	1	1	1	1	133264-1	HOLD DOWN	18
-	1	1	1	1	2119806-1	INSERT, SHEAR	13
-	1	1	1	1	3-22280-3	SPRING, COMPRESSION	12
-	1	1	1	1	1-356885-4	STOP, SHEAR	11
-	1	1	1	1	2119805-1	SHEAR HOLDER, FRONT	10
-	1	1	1	1	1803095-6	FLOATING SHEAR, FRONT	9
-	1	2	2	1	4-1333203-2	ANVIL, COMBINATION	8
-	1	1	1	1	2119780-9	DEPRESSOR, SHEAR	5
-	1	1	1	1	238011-9	BLOCK, CRIMPER SPACER	4
-	1	2	2	1	1-2119784-8	CRIMPER, INSULATION O PREMIUM	3
-	1	1	1	1	455888-1	SPACER, CRIMPER	2
-	1	2	2	1	1-1752057-3	CRIMPER, WIRE PREMIUM, STEPPED	1

ATLANTIC VERSION
Shown on sheets 1 of 4 & 2 of 4
(Pacific version shown on sheets 3 of 4 & 4 of 4)

DIMENSIONS:		TOLERANCES UNLESS OTHERWISE SPECIFIED:		MATERIAL:	
mm	0 PLC ±	1 PLC ±	2 PLC ±	3 PLC ±	4 PLC ±
	ANGLES ±	FINISH ±			

OWN	D. WEAVER	26AUG2011
CHK	C. MOYER	26AUG2011
APVD	T. ELBIN	26AUG2011
NAME	Ocean Side Feed Applicator	
SIZE	CAGE CODE	DRAWING NO
A1	00779	2151468
Customer Accessible Production Drawing	SCALE	1:2
SHEET	1	OF 4
REV	P2	

LOC	DIST	REVISIONS					
		P	LTN	DESCRIPTION	DATE	OWN	APVD
A	66	-	-	SEE SHEET 1	-	-	-

FEED TYPE MECHANICAL

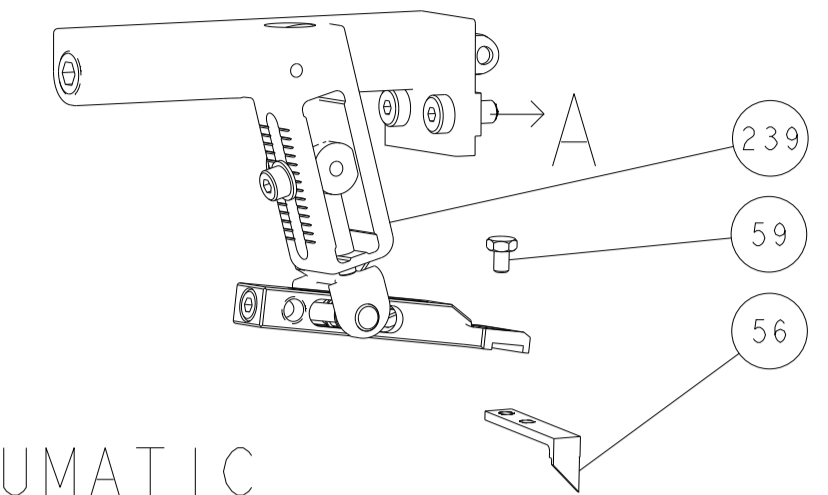

PNEUMATIC

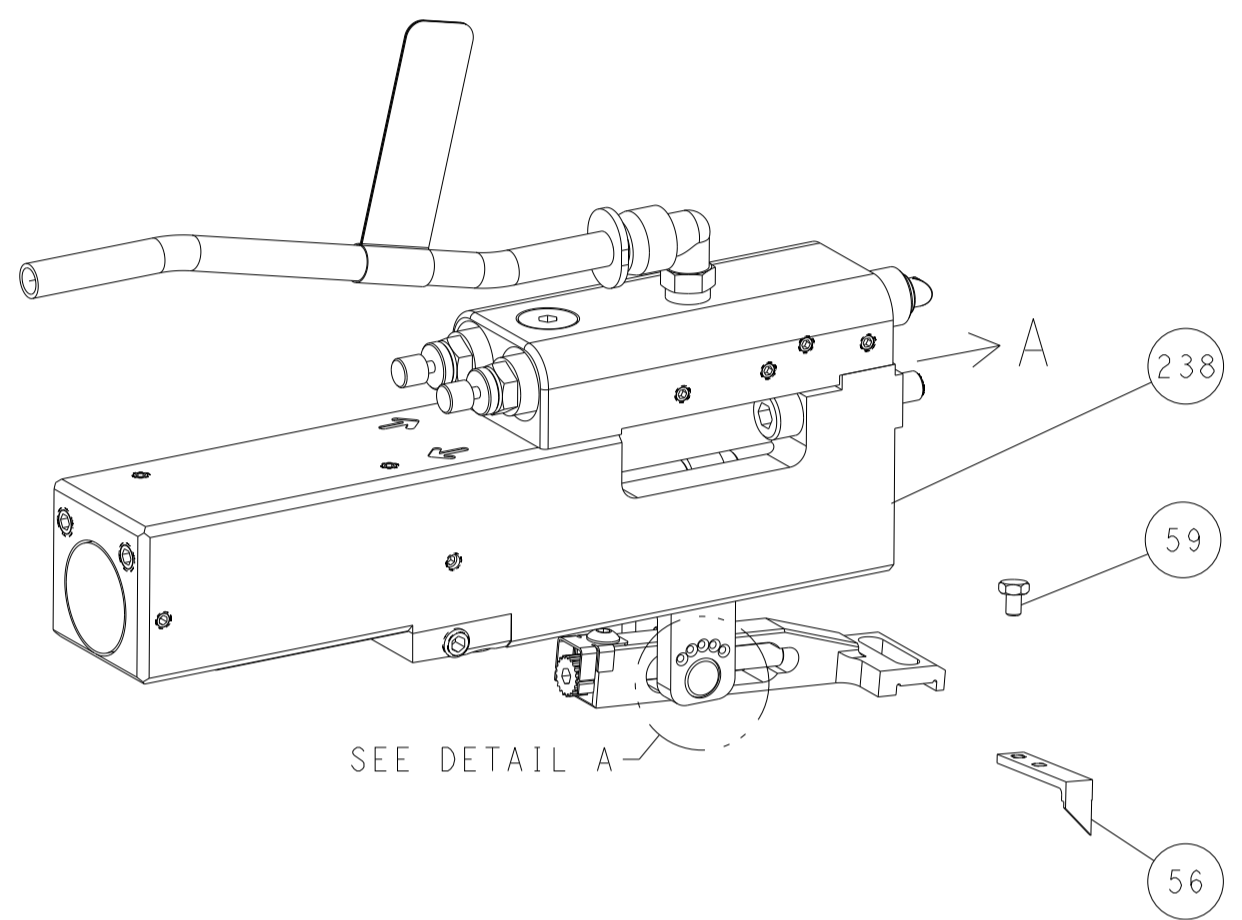

FEED SPRING SETTING POSITION (SHOWN FROM REAR SIDE)



DETAIL A

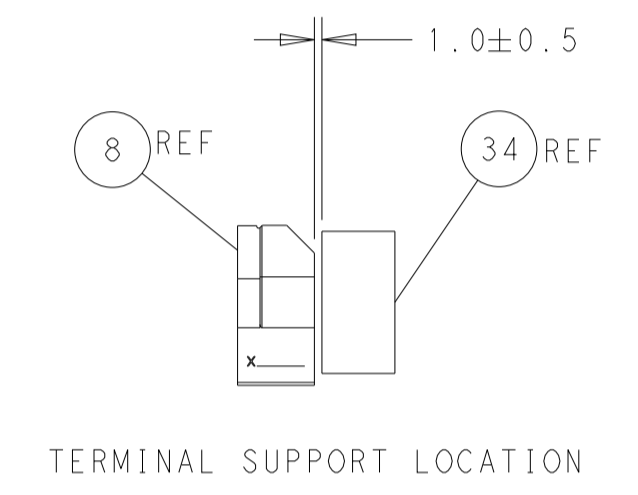
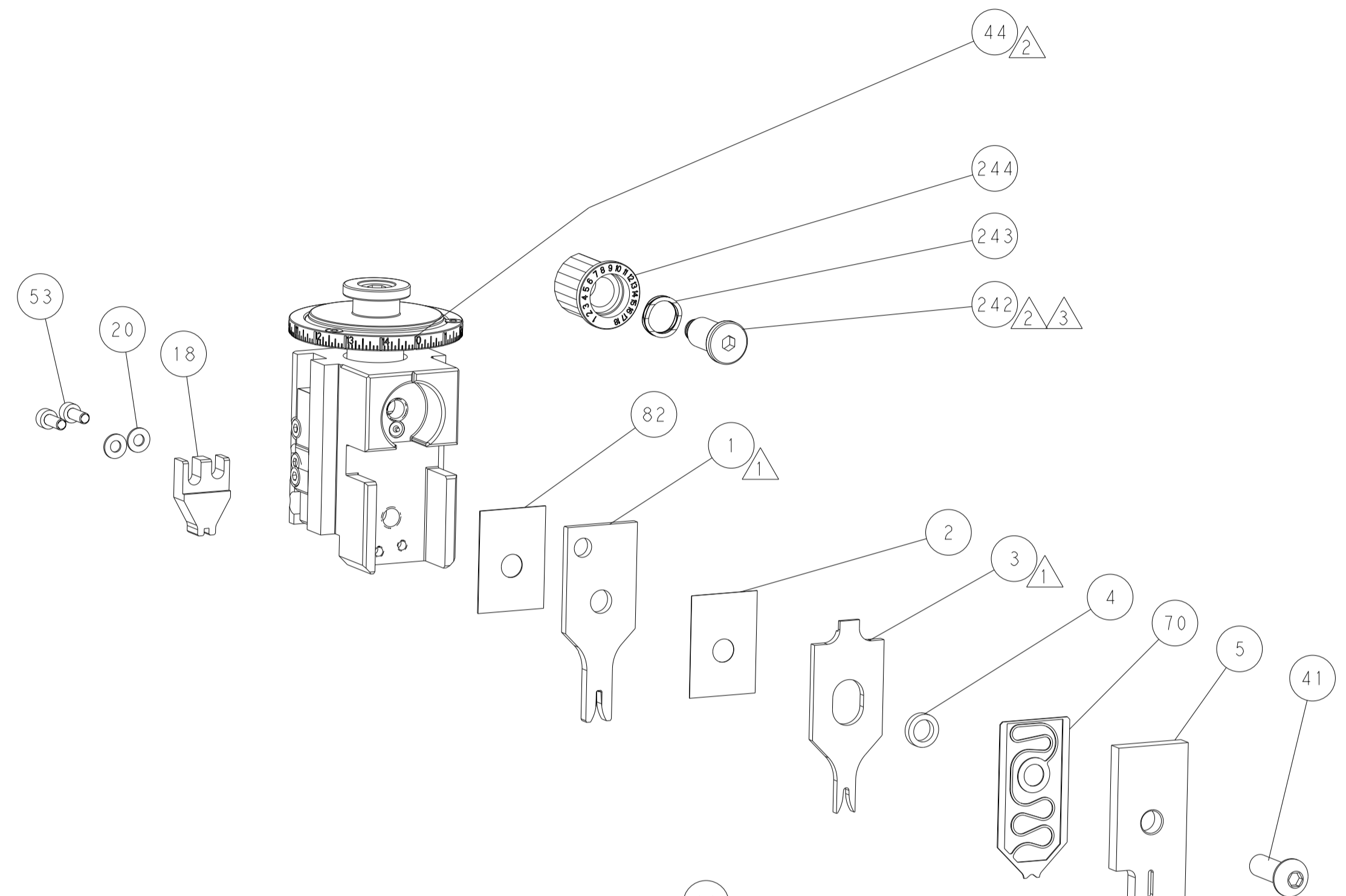

TERMINAL SUPPORT LOCATION

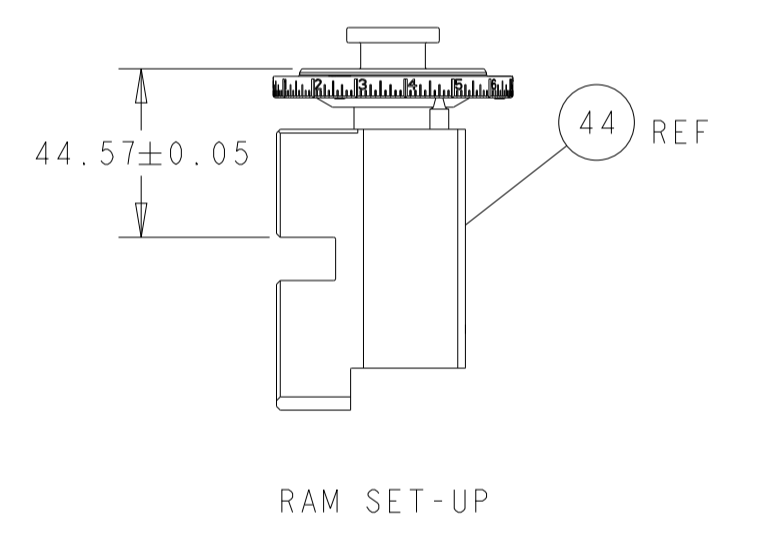

RAM SET-UP

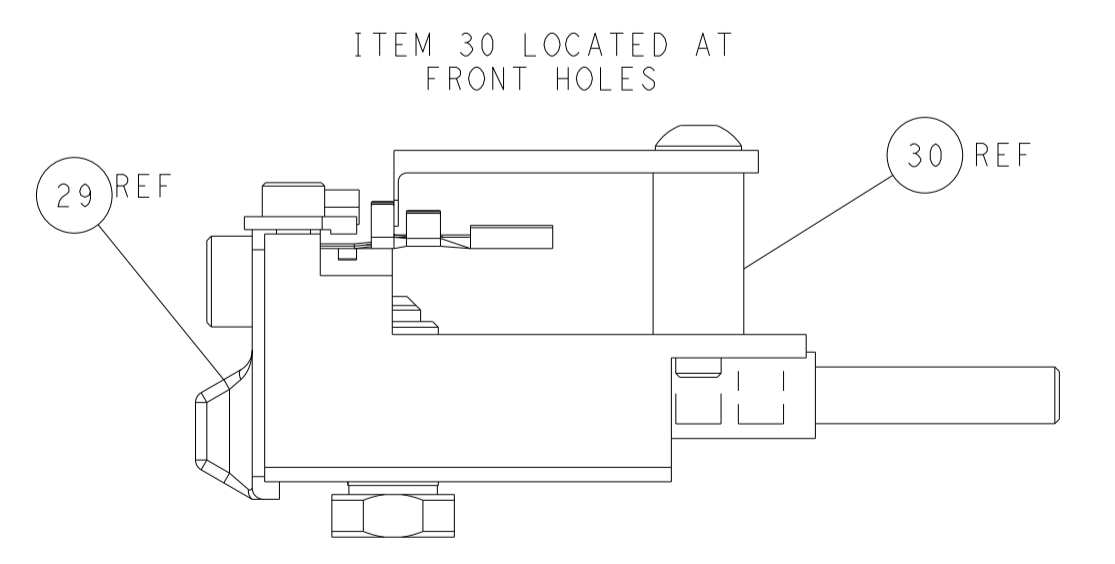

FEED TRACK POSITION GUIDE BY INSULATION BARREL

CAM POSITIONS

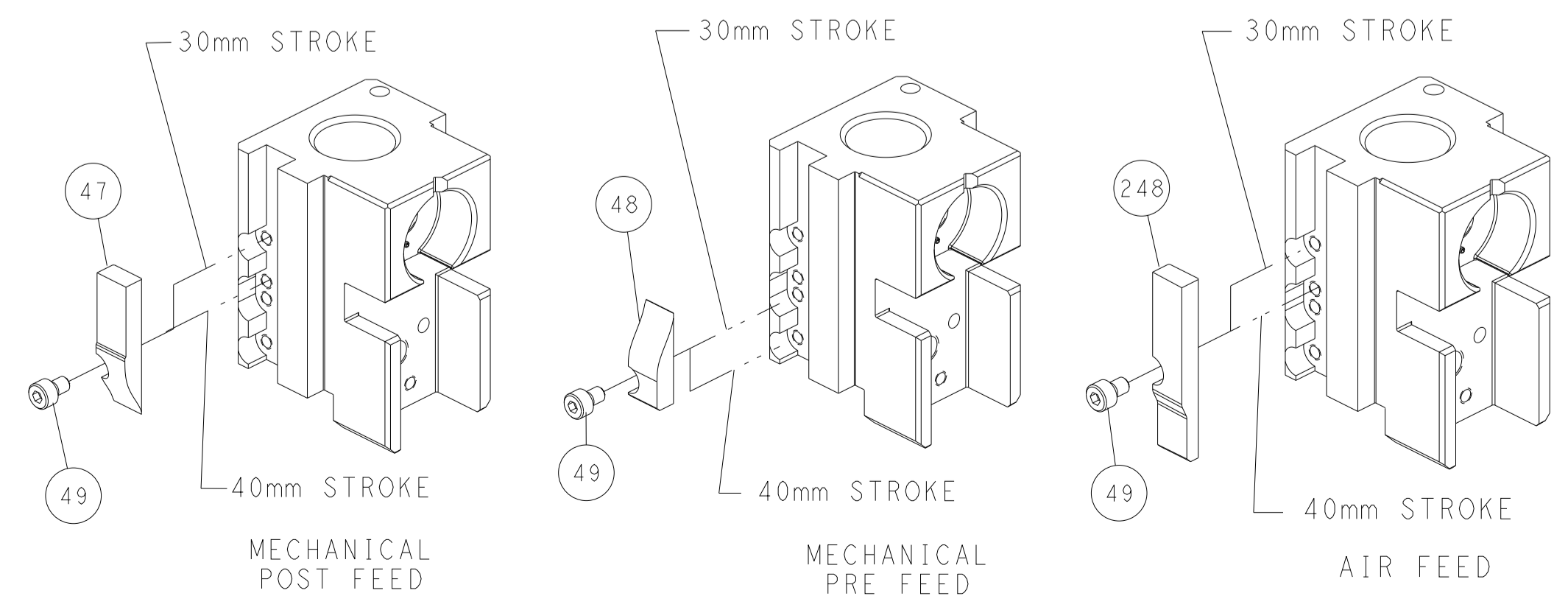

ATLANTIC VERSION
 Shown on sheets 1 of 4 & 2 of 4
 (Pacific version shown on sheets 3 of 4 & 4 of 4)

<small>THIS DRAWING IS UNPUBLISHED. RELEASED FOR PUBLICATION 2011. COPYRIGHT 2011 BY TYCO ELECTRONICS CORPORATION. ALL RIGHTS RESERVED.</small>		DWN B. WEAVER 26AUG2011 CHK C. MOYER 26AUG2011 APVD T. ELBIN 26AUG2011	TE Connectivity Harrisburg, PA 17105-3608
DIMENSIONS: mm TOLERANCES UNLESS OTHERWISE SPECIFIED: 0 PLC ± 1 PLC ± 2 PLC ± 3 PLC ± 4 PLC ± ANGLES FINISH ±		NAME: Ocean Side Feed Applicator SIZE: A1 CAGE CODE: 00779 DRAWING NO: C=2151468 WEIGHT: - SCALE: 1:2 SHEET 2 OF 4 REV P2	RESTRICTED TO: - Customer Accessible Production Drawing

PART NUMBER	REVISION	DESCRIPTION	FEED TYPE
2-2151468-1	P	FINE CRIMP HEIGHT ADJUST	MECHANICAL
2-2151468-2	P	FINE CRIMP HEIGHT ADJUST	PNEUMATIC
7-2151468-7	L	CRIMP TOOLING KIT	-

PACIFIC VERSION TERMINATOR
INTERFACE ADAPTER



APPLICATOR DATA		
CRIMP	SIZE	TYPE
WIRE	1.78 mm [.070]	F
INSUL	2.29 mm [.090]	O
APPLICATOR INSTRUCTIONS 408-35042		

TERMINAL DATA: TE TERMINAL		TE CRIMP SPECIFICATION	
TERMINAL NAME: MCON-1.2 CB			
WIRE STRIP LENGTH	INSULATION DIAMETER RANGE		
3.00-3.60 mm [.118-.142 IN]	Ø 1.60-2.40 mm [.063-.094 IN]		
TERMINAL APPLICATION SPECIFICATION	114-18464	-	-
TERMINALS APPLIED			
TE TERMINAL	TE TERMINAL	TE TERMINAL	TE TERMINAL
1452503-1	1452503-2	1452503-3	

TERMINAL DATA: TE TERMINAL		TE CRIMP SPECIFICATION	
TERMINAL NAME: MCON-1.2 CB			
WIRE STRIP LENGTH	INSULATION DIAMETER RANGE		
3.00-3.60 mm [.118-.142 IN]	Ø 1.60-2.40 mm [.063-.094 IN]		
TERMINAL APPLICATION SPECIFICATION	114-18464	-	-
TERMINALS APPLIED			
TE TERMINAL	TE TERMINAL	TE TERMINAL	TE TERMINAL
1718352-1	1718352-2	1718352-3	

WIRE SIZE	CRIMP HEIGHT mm [INCH]	CRIMP HEIGHT REFERENCE SETTING
1.50mm2	1.36 +/- 0.05 [.054 +/- .002]	3.3
16 AWG	1.31 +/- 0.05 [.052 +/- .002]	3.8
1.00mm2	1.18 +/- 0.05 [.046 +/- .002]	5.2
18 AWG	1.11 +/- 0.05 [.044 +/- .002]	6.0

WIRE SIZE	CRIMP HEIGHT mm [INCH]	CRIMP HEIGHT REFERENCE SETTING
1.50mm2	1.28 +/- 0.05 [.050 +/- .002]	4.2
1.00mm2	1.10 +/- 0.05 [.043 +/- .002]	6.1

- RECOMMENDED SPARE PARTS
 - REFER TO SUPPLIED INSTRUCTION SHEET FOR CLEANING, LUBRICATION AND STORAGE OF APPLICATOR.
 - APPLY PART NUMBER 2-23419-6 LOCTITE TO THREADS OF ITEM 242.
 - CRIMP HEIGHT REFERENCE SETTING WAS THE SETTING USED WHEN THE APPLICATOR WAS QUALIFIED AT THE FACTORY. ADJUSTMENT MAY BE NECESSARY WHEN RUNNING APPLICATOR IN THE FIELD.
 - TERMINAL LUBRICANT IS RECOMMENDED.
6. UNLESS SPECIFIED OTHERWISE TORQUE VALUES SHALL BE USED PER DOCUMENT, 101-35000.

***WARNING**
ON INSTALLATION, SET WIRE DISC TO CRIMP HEIGHT REFERENCE SETTING FOR LARGEST WIRE SIZE. CRIMP HEIGHT REFERENCE SETTINGS GREATER THAN THE VALUE SHOWN MAY CAUSE DAMAGE TO THE CRIMP TOOLING, REFER TO THE INSTRUCTION SHEET FOR PROPER SETUP AND ADJUSTMENTS.

ENTRY LEVEL APPLICATOR		ITEM SUBSTITUTION LIST		
PART NUMBER	SAME AS	ITEM	ITEM DESCRIPTION	SUBSTITUTE PART NUMBER
8-2151468-1	2151468-1	1	WIRE CRIMPER	1-1803621-3
8-2151468-2	2151468-2	3	INSULATION CRIMPER	1-1803604-8
9-2151468-1	2-2151468-1	46	BASIC SUB -ASSEMBLY	1803940-9
9-2151468-2	2-2151468-2	141	BASIC SUB -ASSEMBLY	1-1803940-0
			LUBRICATOR	DELETE

PACIFIC VERSION
Shown on sheets 3 of 4 & 4 of 4
(Atlantic version shown on sheets 1 of 4 & 2 of 4)

LOC	DIST	REVISIONS					
A	66	P	LTN	DESCRIPTION	DATE	OWN	APVD
		-		SEE SHEET 1	-	-	-

-	1	1	2119082-8	CAM, SNAIL, INSULATION ADJUSTMENT	244
-	1	1	2079764-1	WASHER, WAVE SPRING, CREST-TO-CREST	243
3	-	1	2119083-1	RETAINER, INSULATION DIAL	242
-	1	1	7-18023-7	SCR, SKT HD CAP M3 X 4.0	241
-	-	1	2119580-1	MECHANICAL FEED ASSEMBLY	239
-	1	-	2844940-1	AIR FEED MODULE	238
-	REF	REF	994970-2	COUNTER, MAGNETIC	164
-	1	-	2119641-2	FEED CAM, AIR FEED	151
-	1	1	2168083-8	SCR, SKT HD CAP, RoHS, M4 X 16	144
-	4	4	2168083-9	SCR, SKT HD CAP, RoHS, M4 X 20	143
-	-	1	2119653-2	FEED CAM, POST FEED	142
-	1	1	1-1803583-0	APPLICATOR BASIC ASSEMBLY, SF	141
-	1	1	1803516-1	RAM ASSEMBLY, SF PACIFIC	140
-	1	1	1-18028-2	WASHER, FLAT, REG M4	119
5	-	1	2119955-1	ASSY, LUBRICATOR, SIDE FEED	113
-	1	1	2844908-1	SCREW, LOCKING	99
-	1	1	2844907-1	POST, LOCKING	98
-	1	1	455888-4	SPACER, CRIMPER	82
-	1	1	22278-8	SPRING, COMPRESSION	77
-	1	1	854769-4	HOLDER, INS	74
-	1	1	1803607-3	DOCUMENTATION PACKAGE	71
-	1	1	2119791-9	DEPRESSOR, WIRE	70
-	1	1	2119740-1	TAG, IDENTIFICATION	67
-	2	2	2168078-1	SCREW, DRIVE, RH, RoHS, 2 x .188	66
-	1	1	5-18022-5	SCR, HEX HD CAP, M4 X 6.0	59
-	1	1	21028-2	PIN, SLOTTED SPRING .062 X .250	58
-	1	1	1338685-1	PAWL, FEED	56
-	2	2	1-2168083-0	SCR, SKT HD CAP, RoHS, M4 X 10	53
-	1	2	18023-9	SCR, SKT HD CAP M4 X 6.0	49
-	-	1	2119652-1	FEED CAM, PRE FEED	48
-	1	1	1803602-1	SCR, BHSC, RoHS (M8 X 25)	41
-	1	1	1-1752356-8	SUPPORT, TERMINAL	34
-	2	2	2079383-5	SCR, BHSC, RoHS (M4 X 20)	33
-	2	2	2-2844962-6	SPACER, CYLINDRICAL, STRIP GUIDE	30
-	1	1	2844992-2	ASSEMBLY, STRIP GUIDE	29
-	1	1	1320928-2	STRIP GUIDE	24
-	1	1	2168083-2	SCR, SKT HD CAP, RoHS, M4 X 8.0	21
-	3	3	1-18028-2	WASHER, FLAT, REG M4	20
-	1	1	2119533-1	STRIPPER, SIDE FEED	19
-	1	1	1333264-1	HOLD DOWN	18
1	-	1	2119806-1	INSERT, SHEAR	13
-	1	1	3-22280-3	SPRING, COMPRESSION	12
-	1	1	1-356885-4	STOP, SHEAR	11
-	1	1	2119805-1	SHEAR HOLDER, FRONT	10
-	1	1	1803095-6	FLOATING SHEAR, FRONT	9
1	1	1	4-1333203-2	ANVIL, COMBINATION	8
1	1	1	2119780-9	DEPRESSOR, SHEAR	5
-	1	1	238011-9	BLOCK, CRIMPER SPACER	4
1	1	1	1-2119784-8	CRIMPER, INSULATION O PREMIUM	3
1	1	1	455888-1	SPACER, CRIMPER	2
1	1	1	1-1752057-3	CRIMPER, WIRE PREMIUM, STEPPED	1

DIMENSIONS:		TOLERANCES UNLESS OTHERWISE SPECIFIED:		DWG: B. WEAVER 26AUG2011		CHK: C. MOYER 26AUG2011		APVD: T. ELBIN 26AUG2011		NAME: Ocean Side Feed Applicator	
mm	0 PLC ±	1 PLC ±	2 PLC ±	3 PLC ±	4 PLC ±	ANGLES ±	FINISH	SIZE: A1	CAGE CODE: 00779	DRAWING NO: C=2151468	RESTRICTED TO: -
MATERIAL:		FINISH:		WEIGHT:		SCALE: 1:2		SHEET: 3 OF 4		REV: P2	

LOC		DIST		REVISIONS			
A	66	P	LTN	DESCRIPTION	DATE	DWN	APVD
		-		SEE SHEET 1			

FEED TYPE MECHANICAL

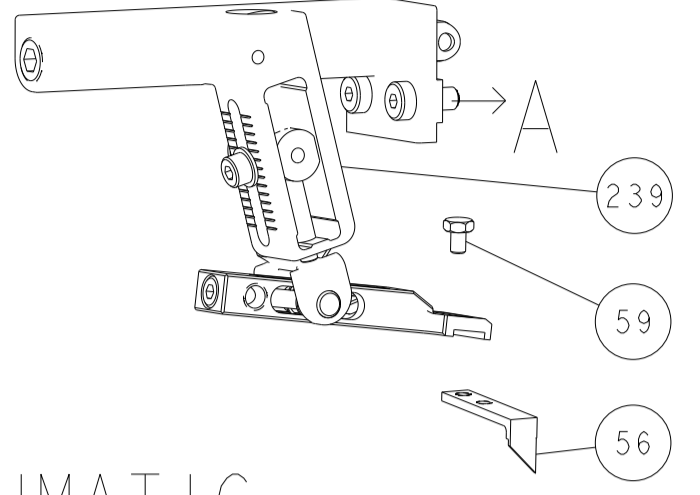

PNEUMATIC

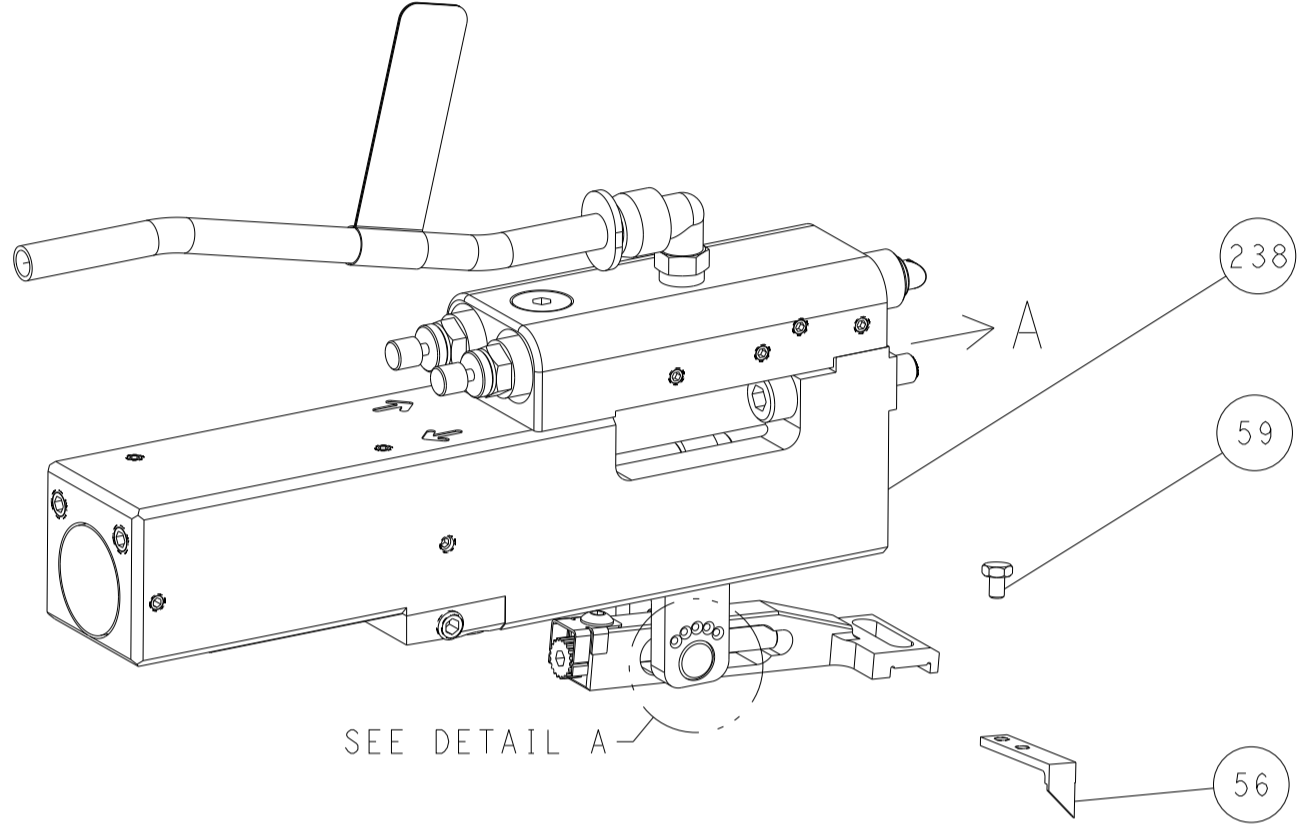

FEED SPRING SETTING POSITION (SHOWN FROM REAR SIDE)

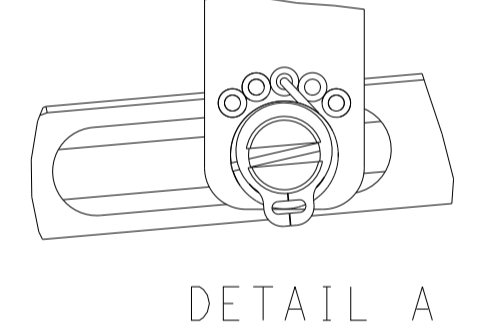

CAM POSITIONS

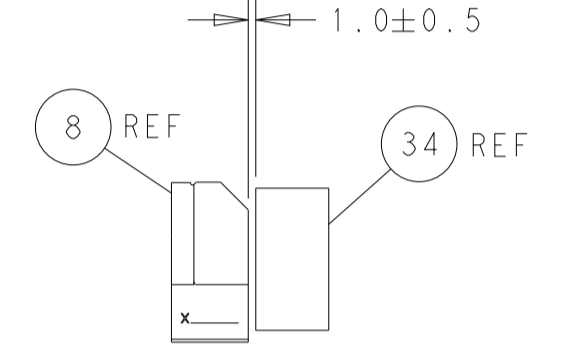
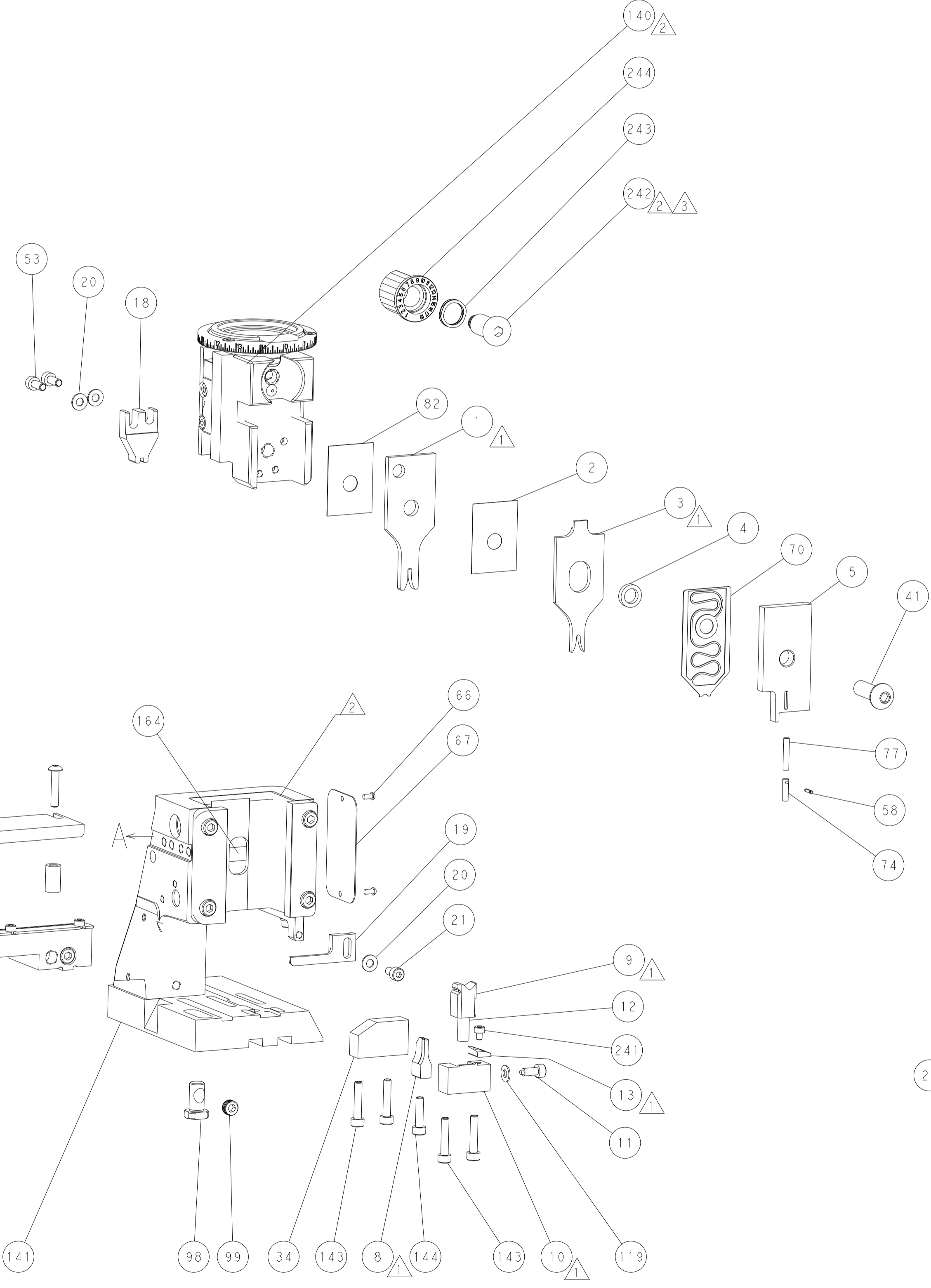
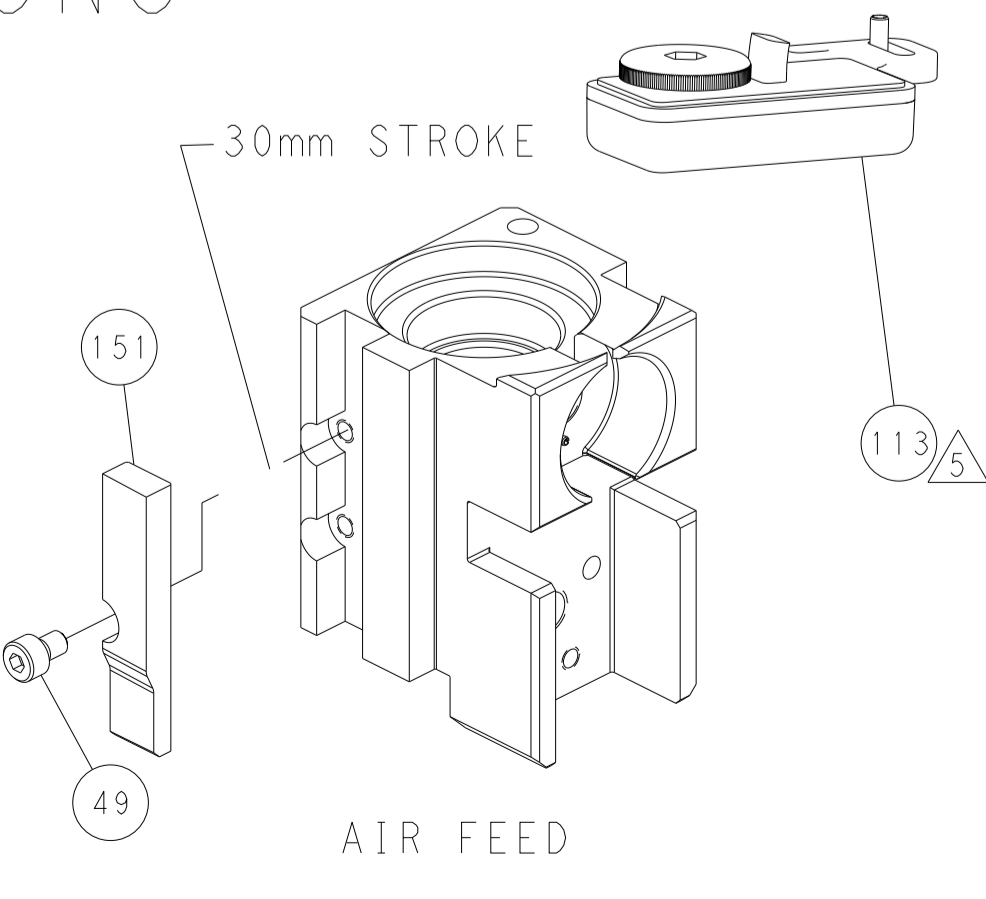
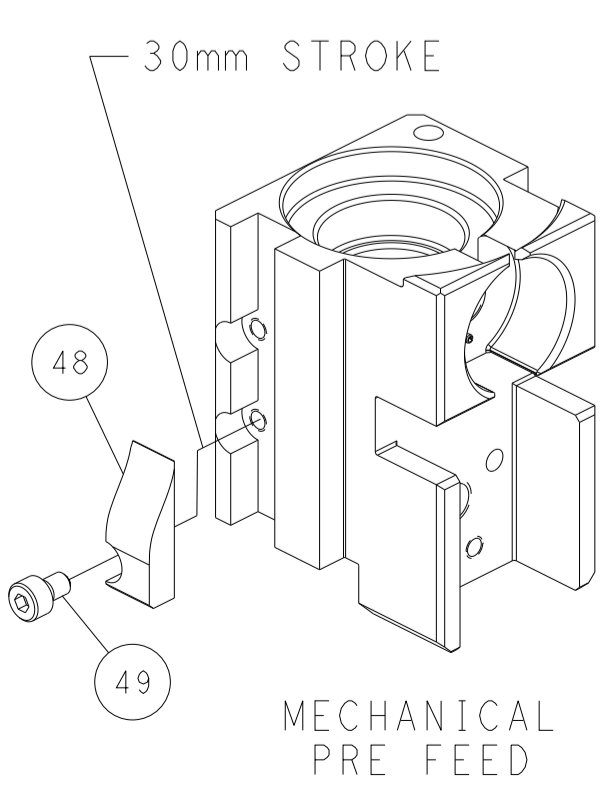
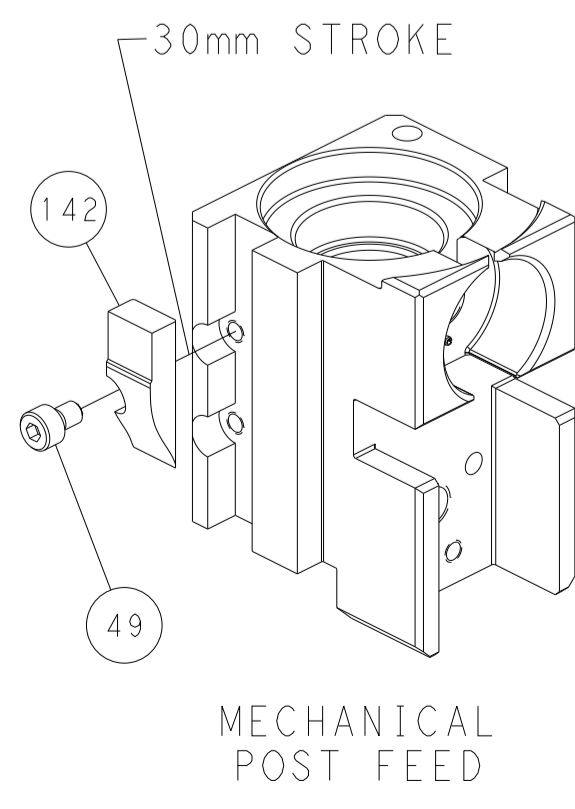

TERMINAL SUPPORT LOCATION

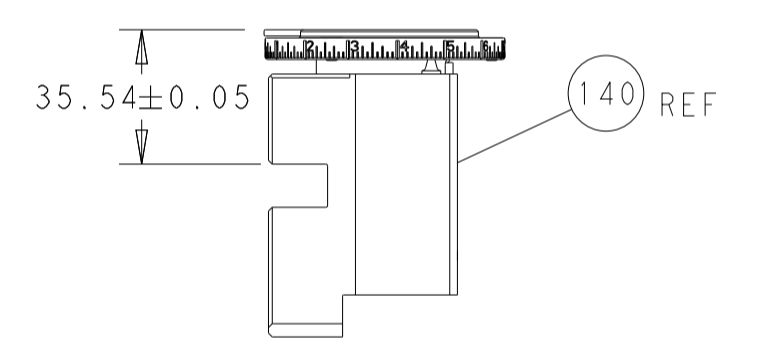

RAM SET-UP

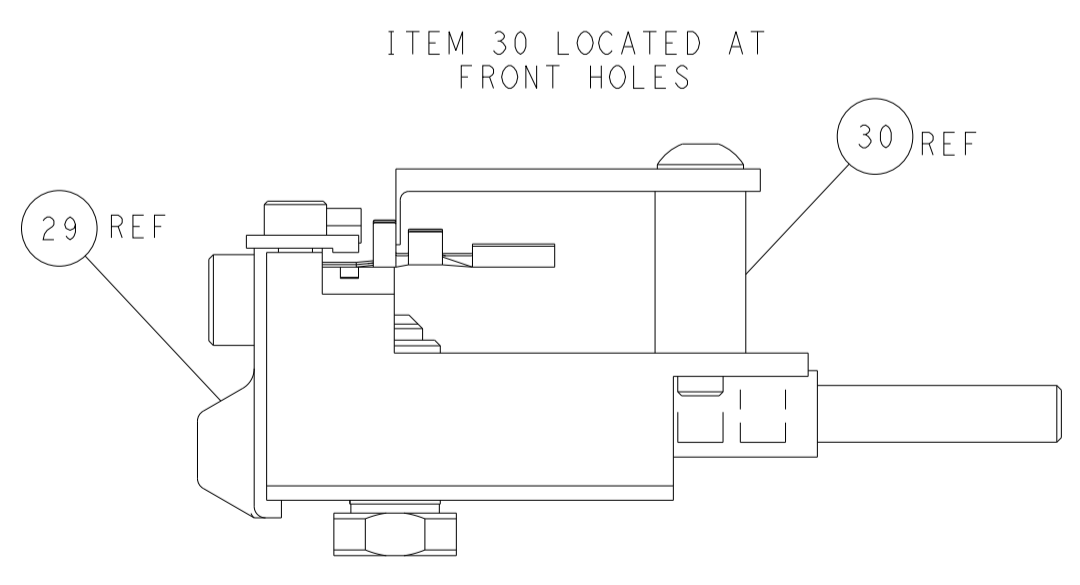

FEED TRACK POSITION GUIDE BY INSULATION BARREL

PACIFIC VERSION
 Shown on sheets 3 of 4 & 4 of 4
 (Atlantic version shown on sheets 1 of 4 & 2 of 4)

<small>THIS DRAWING IS A CONTROLLED DOCUMENT FOR TYCO ELECTRONICS CORPORATION. IT IS THE PROPERTY OF TYCO ELECTRONICS CORPORATION AND IS NOT TO BE REPRODUCED OR TRANSMITTED IN ANY FORM OR BY ANY MEANS, ELECTRONIC OR MECHANICAL, INCLUDING PHOTOCOPYING, RECORDING, OR BY ANY INFORMATION STORAGE AND RETRIEVAL SYSTEM, WITHOUT THE WRITTEN PERMISSION OF TYCO ELECTRONICS CORPORATION.</small>		DWN: B. WEAVER 26AUG2011 CHK: C. MOYER 26AUG2011 APVD: T. ELBIN 26AUG2011	NAME: TE Connectivity Harrisburg, PA 17105-3608
DIMENSIONS: mm TOLERANCES UNLESS OTHERWISE SPECIFIED: 0 PLC ± 1 PLC ± 2 PLC ± 3 PLC ± 4 PLC ± ANGLES ± MATERIAL:	PRODUCT SPEC: APPLICATION SPEC: WEIGHT: SCALE: 1:2	SIZE: A1 CAGE CODE: 00779 DRAWING NO: 2151468	RESTRICTED TO: SHEET 4 OF 4 REV P2