



PCA9641

2-channel I²C-bus master arbiter

Rev. 2.1 — 27 October 2015

Product data sheet

1. General description

The PCA9641 is a 2-to-1 I²C master demultiplexer with an arbiter function. It is designed for high reliability dual master I²C-bus applications where correct system operation is required, even when two I²C-bus masters issue their commands at the same time. The arbiter will select a winner and let it work uninterrupted, and the losing master will take control of the I²C-bus after the winner has finished. The arbiter also allows for queued requests where a master requests the downstream bus while the other master has control.

A race condition occurs when two masters try to access the downstream I²C-bus at almost the same time. The PCA9641 intelligently selects one winning master and the losing master gains control of the bus after the winning master gives up the bus or the reserve time has expired.

Multiple transactions can be done without interruption. The time needed for multiple transactions on the downstream bus can be reserved by programming the Reserve Time register. During the reserve time, the downstream bus cannot be lost.

Software reset allows a master to send a reset through the I²C-bus to put the PCA9641's registers into the power-on reset condition.

The Device ID of the PCA9641 can be read by the master and includes manufacturer, device type and revision.

When there is no activity on the downstream I²C-bus over 100 ms, optionally the PCA9641 will disconnect the downstream bus to both masters to avoid a lock-up on the I²C-bus.

The interrupt outputs are used to provide an indication of which master has control of the bus, and which master has lost the downstream bus. One interrupt input (INT_IN) collects downstream information and propagates it to the two upstream I²C-buses (INT0 and INT1) if enabled. INT0 and INT1 are also used to let the master know if the shared mail box has any new mail or if the outgoing mail has not been read by the other master. Those interrupts can be disabled and will not generate an interrupt if the masking option is set.

The pass gates of the switches are constructed such that the V_{DD} pin can be used to limit the maximum high voltage, which will be passed by the PCA9641. This allows the use of different bus voltages on each pair, so that 1.8 V, 2.5 V, or 3.3 V devices can communicate with 3.3 V devices without any additional protection.

The PCA9641 does not isolate the capacitive loading on either side of the device, so the designer must take into account all trace and device capacitances on both sides of the device, and pull-up resistors must be used on all channels.



External pull-up resistors pull the bus to the desired voltage level for each channel. All I/O pins are 3.6 V tolerant.

An active LOW reset input allows the PCA9641A to be initialized. Pulling the $\overline{\text{RESET}}$ pin LOW resets the I²C-bus state machine and configures the device to its default state as does the internal Power-On Reset (POR) function.

2. Features and benefits

- 2-to-1 bidirectional master selector
- Channel selection via I²C-bus
- I²C-bus interface logic; compatible with SMBus standards
- 2 active LOW interrupt outputs to master controllers
- Active LOW reset input
- Software reset
- Four address pins allowing up to 112 different addresses
- Arbitration active when two masters try to take the downstream I²C-bus at the same time
- The winning master controls the downstream bus until it is done, as long as it is within the reserve time
- Bus time-out after 100 ms on an inactive downstream I²C-bus (optional)
- Readable device ID (manufacturer, device type, and revision)
- Bus initialization/recovery function
- Low R_{on} switches
- Allows voltage level translation between 1.8 V, 2.3 V, 2.5 V, 3.3 V and 3.6 V buses
- No glitch on power-up
- Supports hot insertion
- Software identical for both masters
- Operating power supply voltage range of 2.3 V to 3.6 V
- All I/O pins are 3.6 V tolerant
- Up to 1 MHz clock frequency
- ESD protection exceeds 6000 V HBM per JESD22-A114 and 1000 V CDM per JESD22-C101
- Latch-up testing is done to JEDEC Standard JESD78 which exceeds 100 mA
- Packages offered: TSSOP16, HVQFN16

3. Applications

- High reliability systems with dual masters
- Gatekeeper multiplexer on long single bus
- Bus initialization/recovery for slave devices without hardware reset
- Allows masters without arbitration logic to share resources

4. Ordering information

Table 1. Ordering information

Type number	Topside marking	Package		
		Name	Description	Version
PCA9641BS	641	HVQFN16	plastic thermal enhanced very thin quad flat package; no leads; 16 terminals; body 3 × 3 × 0.85 mm	SOT758-1
PCA9641PW	PCA9641	TSSOP16	plastic thin shrink small outline package; 16 leads; body width 4.4 mm	SOT403-1

4.1 Ordering options

Table 2. Ordering options

Type number	Orderable part number	Package	Packing method	Minimum order quantity	Temperature
PCA9641BS	PCA9641BSHP	HVQFN16	Reel 13" Q2/T3 *Standard mark SMD	6000	T _{amb} = -40 °C to +85 °C
PCA9641PW	PCA9641PWJ	TSSOP16	Reel 13" Q1/T1 *Standard mark SMD	2500	T _{amb} = -40 °C to +85 °C

5. Block diagram

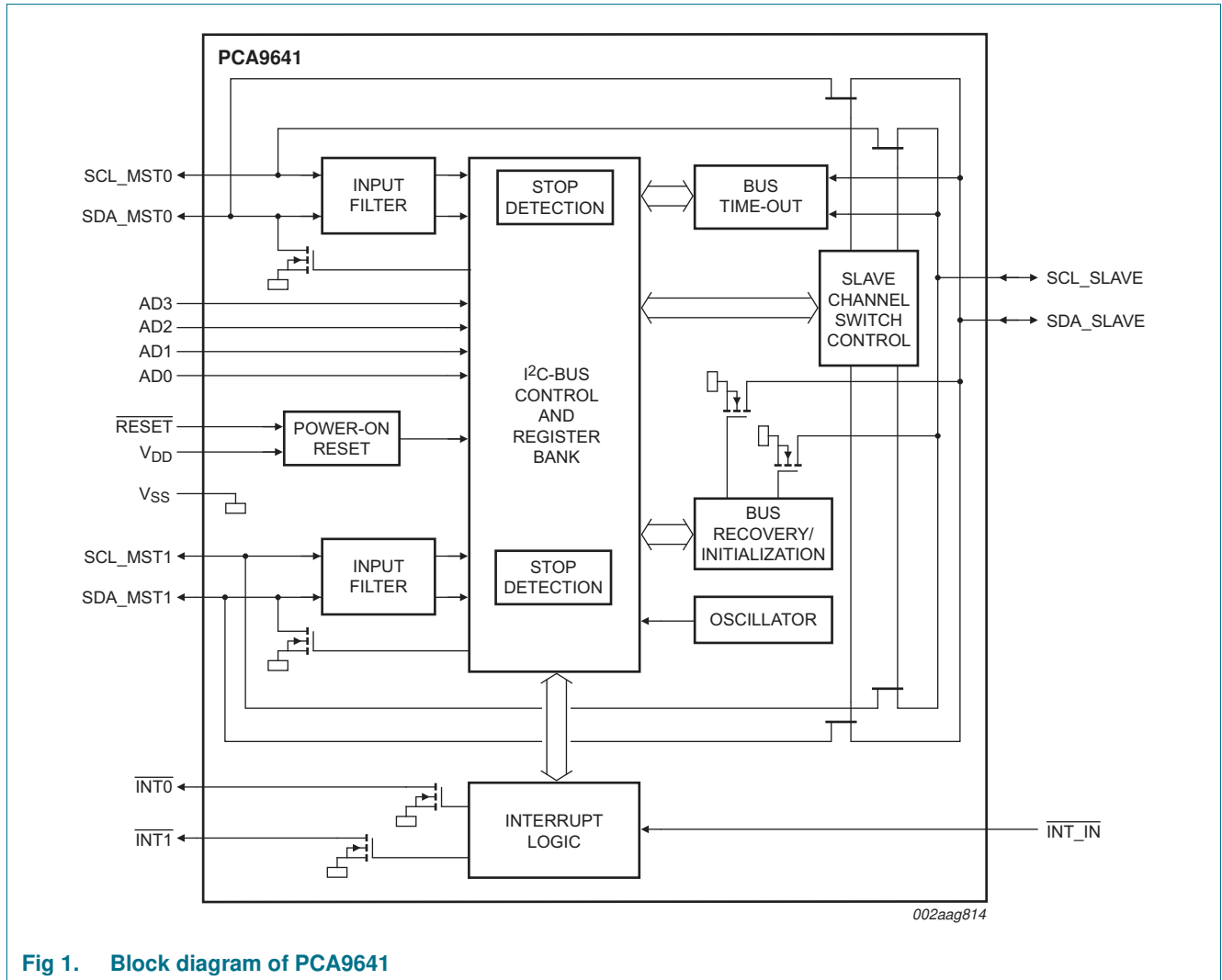

Fig 1. Block diagram of PCA9641

6. Pinning information

6.1 Pinning

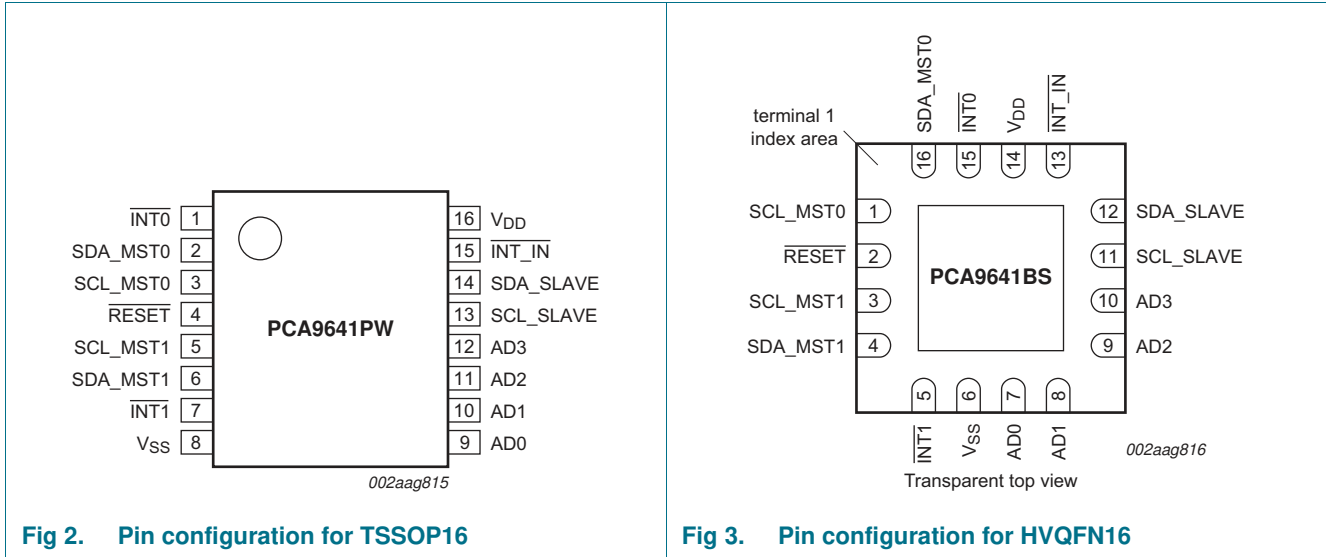

Fig 2. Pin configuration for TSSOP16

Fig 3. Pin configuration for HVQFN16

6.2 Pin description

Table 3. Pin description

Symbol	Pin		Description
	TSSOP16	HVQFN16	
INT0	1	15	active LOW interrupt output 0 (external pull-up required)
SDA_MST0	2	16	serial data master 0 (external pull-up required)
SCL_MST0	3	1	serial clock master 0 (external pull-up required)
RESET	4	2	active LOW reset input (external pull-up required)
SCL_MST1	5	3	serial clock master 1 (external pull-up required)
SDA_MST1	6	4	serial data master 1 (external pull-up required)
INT1	7	5	active LOW interrupt output 1 (external pull-up required)
V _{SS}	8	6 ^[1]	supply ground
AD0	9	7	address input 0 (externally held to V _{SS} , V _{DD} , pull-up to V _{DD} or pull-down to V _{SS})
AD1	10	8	address input 1 (externally held to V _{SS} , V _{DD} , pull-up to V _{DD} or pull-down to V _{SS})
AD2	11	9	address input 2 (externally held to V _{SS} , V _{DD} , pull-up to V _{DD} or pull-down to V _{SS})
AD3	12	10	address input 3 (externally held to V _{SS} , V _{DD} , pull-up to V _{DD} or pull-down to V _{SS})
SCL_SLAVE	13	11	serial clock slave (external pull-up required)
SDA_SLAVE	14	12	serial data slave (external pull-up required)
INT_IN	15	13	active LOW interrupt input (external pull-up required)
V _{DD}	16	14	supply voltage

[1] HVQFN16 package die supply ground is connected to both the V_{SS} pin and the exposed center pad. The V_{SS} pin must be connected to supply ground for proper device operation. For enhanced thermal, electrical, and board-level performance, the exposed pad needs to be soldered to the board using a corresponding thermal pad on the board, and for proper heat conduction through the board thermal vias need to be incorporated in the printed-circuit board in the thermal pad region.

7. Functional description

Refer to [Figure 1 “Block diagram of PCA9641”](#).

7.1 Device address

Following a START condition, the upstream master that wants to control the I²C-bus or make a status check must send the address of the slave it is accessing. To conserve power, no internal pull-up resistors are incorporated on the hardware selectable pins and they must be connected to V_{DD}, V_{SS}, pull-up to V_{DD} or pull-down to V_{SS} directly. PCA9641 can decode 112 addresses, depending on AD3, AD2, AD1 and AD0, and which are found in [Table 5 “Address maps”](#).

At power-up or hardware/software reset, the quinary input pads are sampled and set the slave address of the device internally. To conserve power, once the slave address is determined, the quinary input pads are turned off and will not be sampled until the next time the device is power cycled. [Table 4](#) lists the five possible connections for the quinary input pads along with the external resistor values that must be used.

Table 4. Quinary input pad connection

Pad connection (pins AD3, AD2, AD1, AD0)	Mnemonic	External resistor	
		Min	Max
tie to ground	GND	0 kΩ	17.9 kΩ
resistor pull-down to ground	PD	34.8 kΩ	270 kΩ
resistor pull-up to V _{DD}	PU	31.7 kΩ	340 kΩ
tie to V _{DD}	V _{DD}	0 kΩ	22.1 kΩ

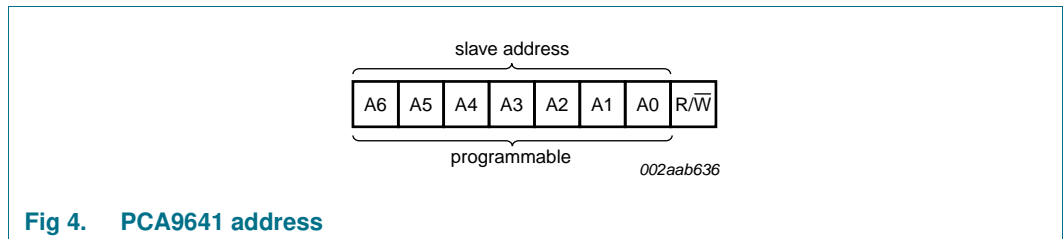

Fig 4. PCA9641 address

7.2 Address maps

Table 5. Address maps

Do not use any other combination addresses to decode hardware addresses.

Pin connectivity				Address of PCA9641								Address byte value		7-bit hexadecimal address without R/W
AD3	AD2	AD1	AD0	A6	A5	A4	A3	A2	A1	A0	R/W	Write	Read	
V _{SS}	V _{SS}	V _{SS}	V _{SS}	1	1	1	0	0	0	0	-	E0h	E1h	70h
V _{SS}	V _{SS}	V _{SS}	V _{DD}	1	1	1	0	0	0	1	-	E2h	E3h	71h
V _{SS}	V _{SS}	V _{DD}	V _{SS}	1	1	1	0	0	1	0	-	E4h	E5h	72h
V _{SS}	V _{SS}	V _{DD}	V _{DD}	1	1	1	0	0	1	1	-	E6h	E7h	73h
V _{SS}	V _{DD}	V _{SS}	V _{SS}	1	1	1	0	1	0	0	-	E8h	E9h	74h
V _{SS}	V _{DD}	V _{SS}	V _{DD}	1	1	1	0	1	0	1	-	EAh	EBh	75h
V _{SS}	V _{DD}	V _{DD}	V _{SS}	1	1	1	0	1	1	0	-	ECh	EDh	76h
V _{SS}	V _{DD}	V _{DD}	V _{DD}	1	1	1	0	1	1	1	-	Eeh	Efh	77h
V _{DD}	V _{SS}	V _{SS}	PD	0	0	0	1	0	0	0	-	10h	11h	08h
V _{DD}	V _{SS}	V _{SS}	PU	0	0	0	1	0	0	1	-	12h	13h	09h
V _{DD}	V _{SS}	V _{DD}	PD	0	0	0	1	0	1	0	-	14h	15h	0Ah
V _{DD}	V _{SS}	V _{DD}	PU	0	0	0	1	0	1	1	-	16h	17h	0Bh
V _{DD}	V _{DD}	V _{SS}	PD	0	0	0	1	1	0	0	-	18h	19h	0Ch
V _{DD}	V _{DD}	V _{SS}	PU	0	0	0	1	1	0	1	-	1Ah	1Bh	0Dh
V _{DD}	V _{DD}	V _{DD}	PD	0	0	0	1	1	1	0	-	1Ch	1Dh	0Eh
V _{DD}	V _{DD}	V _{DD}	PU	0	0	0	1	1	1	1	-	1Eh	1Fh	0Fh
V _{SS}	V _{SS}	PD	V _{SS}	0	0	1	0	0	0	0	-	20h	21h	10h
V _{SS}	V _{SS}	PD	V _{DD}	0	0	1	0	0	0	1	-	22h	23h	11h
V _{SS}	V _{SS}	PU	V _{SS}	0	0	1	0	0	1	0	-	24h	25h	12h
V _{SS}	V _{SS}	PU	V _{DD}	0	0	1	0	0	1	1	-	26h	27h	13h
V _{SS}	V _{DD}	PD	V _{SS}	0	0	1	0	1	0	0	-	28h	29h	14h
V _{SS}	V _{DD}	PD	V _{DD}	0	0	1	0	1	0	1	-	2Ah	2Bh	15h
V _{SS}	V _{DD}	PU	V _{SS}	0	0	1	0	1	1	0	-	2Ch	2Dh	16h
V _{SS}	V _{DD}	PU	V _{DD}	0	0	1	0	1	1	1	-	2Eh	2Fh	17h
V _{DD}	V _{SS}	PD	V _{SS}	0	0	1	1	0	0	0	-	30h	31h	18h
V _{DD}	V _{SS}	PD	V _{DD}	0	0	1	1	0	0	1	-	32h	33h	19h
V _{DD}	V _{SS}	PU	V _{SS}	0	0	1	1	0	1	0	-	34h	35h	1Ah
V _{DD}	V _{SS}	PU	V _{DD}	0	0	1	1	0	1	1	-	36h	37h	1Bh
V _{DD}	V _{DD}	PD	V _{SS}	0	0	1	1	1	0	0	-	38h	39h	1Ch
V _{DD}	V _{DD}	PD	V _{DD}	0	0	1	1	1	0	1	-	3Ah	3Bh	1Dh
V _{DD}	V _{DD}	PU	V _{SS}	0	0	1	1	1	1	0	-	3Ch	3Dh	1Eh
V _{DD}	V _{DD}	PU	V _{DD}	0	0	1	1	1	1	1	-	3Eh	3Fh	1Fh
V _{SS}	V _{SS}	PD	PD	0	1	0	0	0	0	0	-	40h	41h	20h
V _{SS}	V _{SS}	PD	PU	0	1	0	0	0	0	1	-	42h	43h	21h
V _{SS}	V _{SS}	PU	PD	0	1	0	0	0	1	0	-	44h	45h	22h
V _{SS}	V _{SS}	PU	PU	0	1	0	0	0	1	1	-	46h	47h	23h
V _{SS}	V _{DD}	PD	PD	0	1	0	0	1	0	0	-	48h	49h	24h
V _{SS}	V _{DD}	PD	PU	0	1	0	0	1	0	1	-	4Ah	4Bh	25h

Table 5. Address maps ...continued

Do not use any other combination addresses to decode hardware addresses.

Pin connectivity				Address of PCA9641								Address byte value		7-bit hexadecimal address without R/W
AD3	AD2	AD1	AD0	A6	A5	A4	A3	A2	A1	A0	R/W	Write	Read	
V _{SS}	V _{DD}	PU	PD	0	1	0	0	1	1	0	-	4Ch	4Dh	26h
V _{SS}	V _{DD}	PU	PU	0	1	0	0	1	1	1	-	4Eh	4Fh	27h
V _{DD}	V _{SS}	PD	PD	0	1	0	1	0	0	0	-	50h	51h	28h
V _{DD}	V _{SS}	PD	PU	0	1	0	1	0	0	1	-	52h	53h	29h
V _{DD}	V _{SS}	PU	PD	0	1	0	1	0	1	0	-	54h	55h	2Ah
V _{DD}	V _{SS}	PU	PU	0	1	0	1	0	1	1	-	56h	57h	2Bh
V _{DD}	V _{DD}	PD	PD	0	1	0	1	1	0	0	-	58h	59h	2Ch
V _{DD}	V _{DD}	PD	PU	0	1	0	1	1	0	1	-	5Ah	5Bh	2Dh
V _{DD}	V _{DD}	PU	PD	0	1	0	1	1	1	0	-	5Ch	5Dh	2Eh
V _{DD}	V _{DD}	PU	PU	0	1	0	1	1	1	1	-	5Eh	5Fh	2Fh
V _{SS}	PD	V _{SS}	V _{SS}	0	1	1	0	0	0	0	-	60h	61h	30h
V _{SS}	PD	V _{SS}	V _{DD}	0	1	1	0	0	0	1	-	62h	63h	31h
V _{SS}	PD	V _{DD}	V _{SS}	0	1	1	0	0	1	0	-	64h	65h	32h
V _{SS}	PD	V _{DD}	V _{DD}	0	1	1	0	0	1	1	-	66h	67h	33h
V _{SS}	PU	V _{SS}	V _{SS}	0	1	1	0	1	0	0	-	68h	69h	34h
V _{SS}	PU	V _{SS}	V _{DD}	0	1	1	0	1	0	1	-	6Ah	6Bh	35h
V _{SS}	PU	V _{DD}	V _{SS}	0	1	1	0	1	1	0	-	6Ch	6Dh	36h
V _{SS}	PU	V _{DD}	V _{DD}	0	1	1	0	1	1	1	-	6Eh	6Fh	37h
V _{DD}	PD	V _{SS}	V _{SS}	0	1	1	1	0	0	0	-	70h	71h	38h
V _{DD}	PD	V _{SS}	V _{DD}	0	1	1	1	0	0	1	-	72h	73h	39h
V _{DD}	PD	V _{DD}	V _{SS}	0	1	1	1	0	1	0	-	74h	75h	3Ah
V _{DD}	PD	V _{DD}	V _{DD}	0	1	1	1	0	1	1	-	76h	77h	3Bh
V _{DD}	PU	V _{SS}	V _{SS}	0	1	1	1	1	0	0	-	78h	79h	3Ch
V _{DD}	PU	V _{SS}	V _{DD}	0	1	1	1	1	0	1	-	7Ah	7Bh	3Dh
V _{DD}	PU	V _{DD}	V _{SS}	0	1	1	1	1	1	0	-	7Ch	7Dh	3Eh
V _{DD}	PU	V _{DD}	V _{DD}	0	1	1	1	1	1	1	-	7Eh	7Fh	3Fh
V _{SS}	PD	V _{SS}	PD	1	0	0	0	0	0	0	-	80h	81h	40h
V _{SS}	PD	V _{SS}	PU	1	0	0	0	0	0	1	-	82h	83h	41h
V _{SS}	PD	V _{DD}	PD	1	0	0	0	0	1	0	-	84h	85h	42h
V _{SS}	PD	V _{DD}	PU	1	0	0	0	0	1	1	-	86h	87h	43h
V _{SS}	PU	V _{SS}	PD	1	0	0	0	1	0	0	-	88h	89h	44h
V _{SS}	PU	V _{SS}	PU	1	0	0	0	1	0	1	-	8Ah	8Bh	45h
V _{SS}	PU	V _{DD}	PD	1	0	0	0	1	1	0	-	8Ch	8Dh	46h
V _{SS}	PU	V _{DD}	PU	1	0	0	0	1	1	1	-	8Eh	8Fh	47h
V _{DD}	PD	V _{SS}	PD	1	0	0	1	0	0	0	-	90h	91h	48h
V _{DD}	PD	V _{SS}	PU	1	0	0	1	0	0	1	-	92h	93h	49h
V _{DD}	PD	V _{DD}	PD	1	0	0	1	0	1	0	-	94h	95h	4Ah
V _{DD}	PD	V _{DD}	PU	1	0	0	1	0	1	1	-	96h	97h	4Bh
V _{DD}	PU	V _{SS}	PD	1	0	0	1	1	0	0	-	98h	99h	4Ch

Table 5. Address maps ...continued

Do not use any other combination addresses to decode hardware addresses.

Pin connectivity				Address of PCA9641								Address byte value		7-bit hexadecimal address without R/W
AD3	AD2	AD1	AD0	A6	A5	A4	A3	A2	A1	A0	R/W	Write	Read	
V _{DD}	PU	V _{SS}	PU	1	0	0	1	1	0	1	-	9Ah	9Bh	4Dh
V _{DD}	PU	V _{DD}	PD	1	0	0	1	1	1	0	-	9Ch	9Dh	4Eh
V _{DD}	PU	V _{DD}	PU	1	0	0	1	1	1	1	-	9Eh	9Fh	4Fh
V _{SS}	PD	PD	V _{SS}	1	0	1	0	0	0	0	-	A0h	A1h	50h
V _{SS}	PD	PD	V _{DD}	1	0	1	0	0	0	1	-	A2h	A3h	51h
V _{SS}	PD	PU	V _{SS}	1	0	1	0	0	1	0	-	A4h	A5h	52h
V _{SS}	PD	PU	V _{DD}	1	0	1	0	0	1	1	-	A6h	A7h	53h
V _{SS}	PU	PD	V _{SS}	1	0	1	0	1	0	0	-	A8h	A9h	54h
V _{SS}	PU	PD	V _{DD}	1	0	1	0	1	0	1	-	AAh	ABh	55h
V _{SS}	PU	PU	V _{SS}	1	0	1	0	1	1	0	-	ACh	ADh	56h
V _{SS}	PU	PU	V _{DD}	1	0	1	0	1	1	1	-	A Eh	A Fh	57h
V _{DD}	PD	PD	V _{SS}	1	0	1	1	0	0	0	-	B0h	B1h	58h
V _{DD}	PD	PD	V _{DD}	1	0	1	1	0	0	1	-	B2h	B3h	59h
V _{DD}	PD	PU	V _{SS}	1	0	1	1	0	1	0	-	B4h	B5h	5Ah
V _{DD}	PD	PU	V _{DD}	1	0	1	1	0	1	1	-	B6h	B7h	5Bh
V _{DD}	PU	PD	V _{SS}	1	0	1	1	1	0	0	-	B8h	B9h	5Ch
V _{DD}	PU	PD	V _{DD}	1	0	1	1	1	0	1	-	BAh	BBh	5Dh
V _{DD}	PU	PU	V _{SS}	1	0	1	1	1	1	0	-	BCh	BDh	5Eh
V _{DD}	PU	PU	V _{DD}	1	0	1	1	1	1	1	-	BEh	BFh	5Fh
V _{SS}	PD	PD	PD	1	1	0	0	0	0	0	-	C0h	C1h	60h
V _{SS}	PD	PD	PU	1	1	0	0	0	0	1	-	C2h	C3h	61h
V _{SS}	PD	PU	PD	1	1	0	0	0	1	0	-	C4h	C5h	62h
V _{SS}	PD	PU	PU	1	1	0	0	0	1	1	-	C6h	C7h	63h
V _{SS}	PU	PD	PD	1	1	0	0	1	0	0	-	C8h	C9h	64h
V _{SS}	PU	PD	PU	1	1	0	0	1	0	1	-	CAh	CBh	65h
V _{SS}	PU	PU	PD	1	1	0	0	1	1	0	-	CCh	CDh	66h
V _{SS}	PU	PU	PU	1	1	0	0	1	1	1	-	CEh	CFh	67h
V _{DD}	PD	PD	PD	1	1	0	1	0	0	0	-	D0h	D1h	68h
V _{DD}	PD	PD	PU	1	1	0	1	0	0	1	-	D2h	D3h	69h
V _{DD}	PD	PU	PD	1	1	0	1	0	1	0	-	D4h	D5h	6Ah
V _{DD}	PD	PU	PU	1	1	0	1	0	1	1	-	D6h	D7h	6Bh
V _{DD}	PU	PD	PD	1	1	0	1	1	0	0	-	D8h	D9h	6Ch
V _{DD}	PU	PD	PU	1	1	0	1	1	0	1	-	DAh	DBh	6Dh
V _{DD}	PU	PU	PD	1	1	0	1	1	1	0	-	DCh	DDh	6Eh
V _{DD}	PU	PU	PU	1	1	0	1	1	1	1	-	DEh	DFh	6Fh

7.3 Command Code

Following the successful acknowledgement of the slave address, the bus master will send a byte to the PCA9641, which will be stored in the Command Code register.

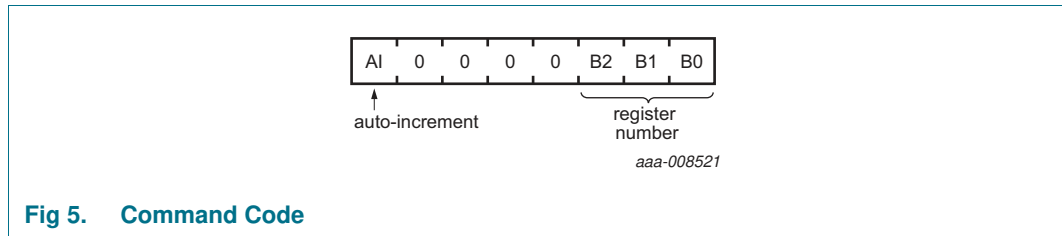

The 3 LSBs are used as a pointer to determine which register will be accessed. If the auto-increment flag is set (AI = 1), the three least significant bits of the Command Code are automatically incremented after a byte has been read or written. This allows the user to program the registers sequentially or to read them sequentially.

- During a read operation, the contents of these bits will roll over to 000b after the last allowed register is accessed (111b).
- During a write operation, the PCA9641 will acknowledge bytes sent to the CONTR, STATUS, RT, INT_STATUS, INT_MSK, MB_LO and MB_HI registers, but will not acknowledge bytes sent to the ID register since it is a read-only register. The 3 LSBs of the Command Code do not roll over to 000b but stay at 111b.

Only the 3 least significant bits are affected by the AI flag.

Unused bits must be programmed with zeros. Any command code (write operation) different from 'AI000 0000', 'AI000 0001', 'AI000 0010', 'AI000 0011', 'AI000 0100', 'AI000 0101', 'AI000 0110' and 'AI000 111' will not be acknowledged. At power-up, this register defaults to all zeros.

Table 6. Command Code register

B2	B1	B0	Register name	Type	Register function
0	0	0	ID	R only	8-bit device ID
0	0	1	CONTR	R/W	control register
0	1	0	STATUS	R/W	status register
0	1	1	RT	R/W	reserve time
1	0	0	INT_STATUS	R/W	interrupt status register
1	0	1	INT_MSK	R/W	interrupt mask register
1	1	0	MB_LO	R/W	low 8 bits of the mail box
1	1	1	MB_HI	R/W	high 8 bits of the mail box

Each system master controls its own set of registers, however they can also read specific bits from the other system master.

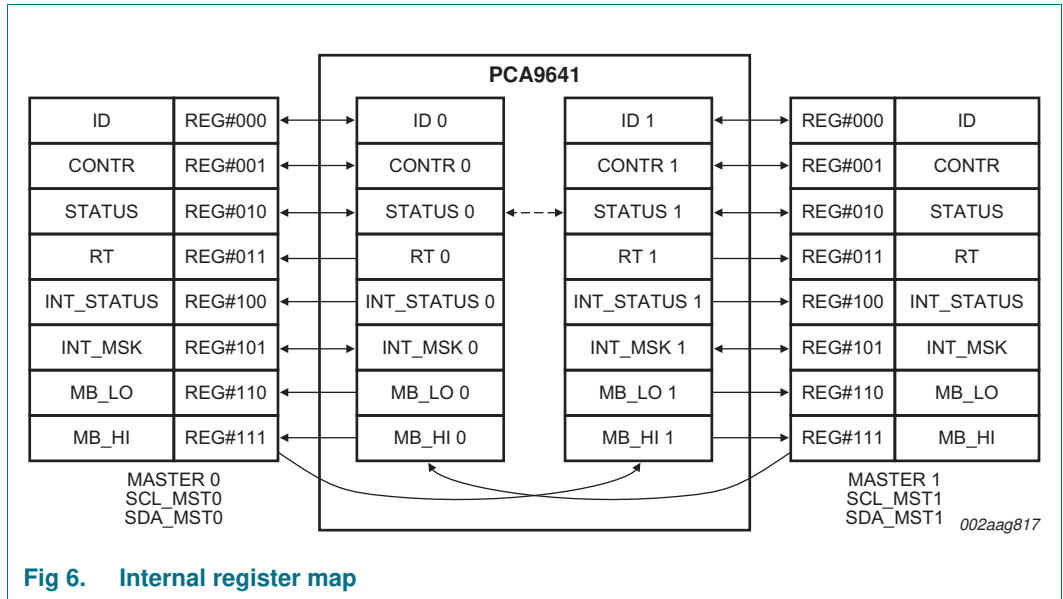

Fig 6. Internal register map

7.4 Power-on reset

When power (from 0 V) is applied to V_{DD}, an internal power-on reset holds the PCA9641 in a reset condition until V_{DD} has reached V_{POR}. At that time, the reset condition is released and the PCA9641 registers and I²C-bus/SMBus state machine initialize to their default states. After that, V_{DD} must be lowered to below V_{POR} and back up to the operating voltage for a power-reset cycle.

7.5 Reset input ($\overline{\text{RESET}}$)

The $\overline{\text{RESET}}$ input can be asserted to initialize the system while keeping the V_{DD} at its operating level. A reset is accomplished by holding the $\overline{\text{RESET}}$ pin LOW for a minimum of t_{w(rst)}. The PCA9641 registers and I²C-bus/SMBus state machine are set to their default state once $\overline{\text{RESET}}$ is LOW (0). When $\overline{\text{RESET}}$ is HIGH (1), normal operation resumes and the I²C downstream bus has no connection to any I²C-bus master.

7.6 Software reset

When granted or non-granted master sends a software reset (see [Section 13 “General call software reset”](#)), PCA9641 will reset all internal registers and:

- If SMBUS_SWRST was enabled before software reset happens, PCA9641 sends SCL LOW for greater than 35 ms to downstream bus following a soft reset.
- If SMBUS_SWRST was disabled before software reset happens, PCA9641 does **not** send SCL LOW to downstream bus following a soft reset.

7.7 Voltage translation

The pass gate transistors of the PCA9641 are constructed such that the V_{DD} voltage can be used to limit the maximum voltage that will be passed from one I²C-bus to another.

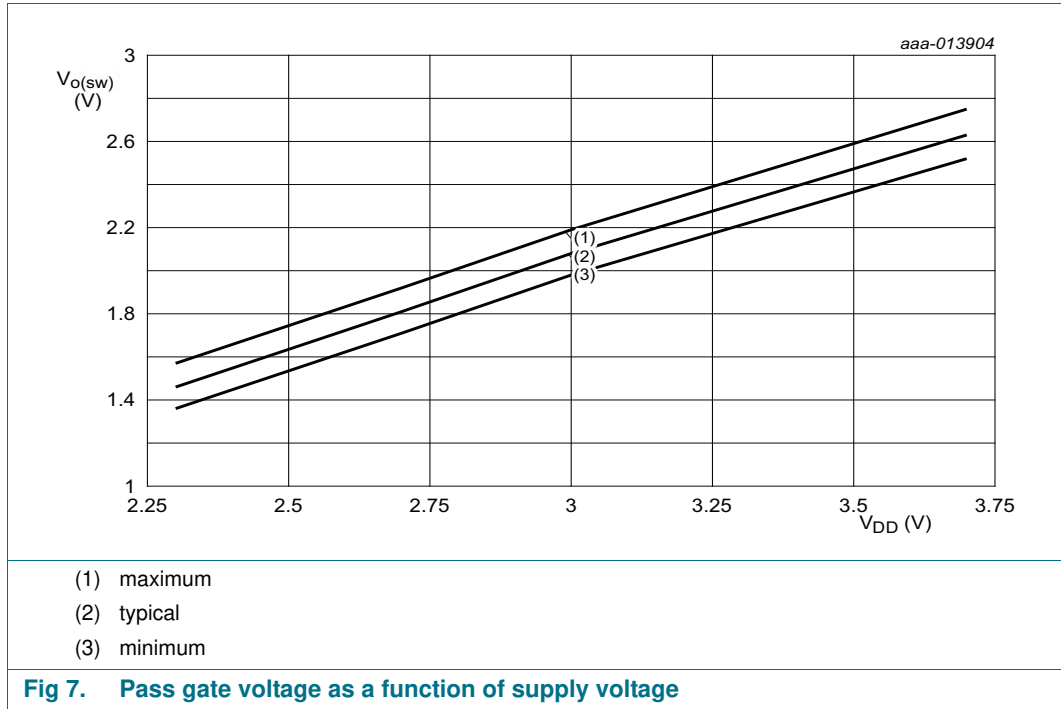

Fig 7. Pass gate voltage as a function of supply voltage

Figure 7 shows the voltage characteristics of the pass gate transistors (note that the graph was generated using the data specified in Section 18 “Static characteristics” of this data sheet). In order for the PCA9641 to act as a voltage translator, the V_{o(sw)} voltage should be equal to, or lower than the lowest bus voltage. For example, if the main buses were running at 3.3 V, and the downstream bus was 2.5 V, then V_{o(sw)} should be equal to or below 2.5 V to effectively clamp the downstream bus voltages. Looking at Figure 7, we see that V_{o(sw)(max)} will be at 2.5 V when the PCA9641 supply voltage is 3.375 V or lower so the PCA9641 supply voltage could be set to 3.3 V. Pull-up resistors can then be used to bring the bus voltages to their appropriate levels (see Figure 20).

More Information on voltage translation can be found in Application Note AN262: PCA954X family of I²C/SMBus multiplexers and switches.

8. Register descriptions

8.1 Register 0: ID register ([B2:B0] = 000b)

This register is holding the last 8 bits of the Device ID. It is used to distinguish between PCA9541 and PCA9641. When a master reads this register, if the value returned from this register is 38h, it is PCA9641, other than this value it is PCA9541.

Table 7. ID - Device ID register (pointer address 00h) bit description
POR = 38h.

Address	Register	Bit	Access	Description
00h	ID	7:0	R only	Hard-coded 38h for PCA9641.

8.2 Register 1: Control register ([B2:B0] = 001b)

The Control register described below is identical for both the masters. Nevertheless, there are physically two internal Control registers, one for each upstream channel. When master 0 reads/writes in this register, the internal CONTR Register 0 will be accessed. When master 1 reads/writes in this register, the internal CONTR Register 1 will be accessed.

Table 8. CONTR - Control register (pointer address 01h) bit description
POR = 00h.
Legend: * default value

Bit	Symbol	Access	Value	Description
7	PRIORITY	R/W		Master can set this register bit for setting priority of the winner when two masters request the downstream bus at the same time. Table 9 shows how PCA9641 selects the winner when 2 masters set their own PRIORITY bit.
			0*	Master can configure the priority bit for the case where two masters request the downstream bus at the same time. See Table 9 for information on how PCA9641 selects the winner.
6	SMBUS_DIS	R/W		When PCA9641 detects an SMBus time-out, if this bit is set, PCA9641 will disconnect I ² C-bus from master to downstream bus.
			0*	Normal operation
			1	Connectivity between master and downstream bus will be disconnected upon detecting an SMBus time-out condition.

Table 8. CONTR - Control register (pointer address 01h) bit description ...continued

POR = 00h.

Legend: * default value

Bit	Symbol	Access	Value	Description
5	IDLE_TIMER_DIS	R/W		After RES_TIME is expired, I ² C-bus idle for more than 100 ms, PCA9641 will disconnect master from downstream bus and takes away its grant if this register bit is enabled. This IDLE_TIMER_DIS function also applies when there is a grant of a request with zero value on RES_TIME.
			0*	Normal operation.
			1	Enable 100 ms idle timer. After reserve timer expires or if reserve timer is disabled, if the downstream bus is idle for more than 100 ms, the connection between master and downstream bus will be disconnected.
4	SMBUS_SWRST	R/W		Non-granted or granted master sends a soft reset, if this bit is set, PCA9641 sets clock LOW for 35 ms following reset of all register values to defaults.
			0*	Normal operation.
			1	Enable sending SMBus time-out to downstream bus, after receiving a general call soft reset from master.
3	BUS_INIT	R/W		Bus initialization for PCA9641 sends one clock out and checks SDA signal. If SDA is HIGH, PCA9641 sends a 'not acknowledge' and a STOP condition. The BUS_INIT function is completed. If SDA is LOW, PCA9641 sends other clock out and checks SDA again. The PCA9641 will send out 9 clocks (maximum), and if SDA is still LOW, PCA9641 determines the bus initialization has failed.
			0*	Normal operation.
			1	Start initialization on next bus connect function to downstream bus.
2	BUS_CONNECT	R/W		Connectivity between master and downstream bus; the internal switch connects I ² C-bus from master to downstream bus only if LOCK_GRANT = 1.
			0*	Do not connect I ² C-bus from master to downstream bus.
			1	Connect downstream bus; the internal switch is closed only if LOCK_GRANT = 1.
1	LOCK_GRANT	R only		This is a status read only register bit. Lock grant status register bit indicates the ownership between reading master and the downstream bus. If this register bit is 1, the reading master has owned the downstream bus. If this register bit is zero, the reading master has not owned the downstream bus.
			0*	This master does not have a lock on the downstream bus.
			1	This master has a lock on the downstream bus.

Table 8. CONTR - Control register (pointer address 01h) bit description ...continued

POR = 00h.

Legend: * default value

Bit	Symbol	Access	Value	Description
0	LOCK_REQ	R/W		Lock request register bit is for a master requesting the downstream bus when it does not have a lock on downstream bus. When a master has a lock on downstream bus, it can give up the ownership by writing zero to LOCK_REQ register bit. When LOCK_REQ becomes zero, LOCK_GRANT bit becomes zero and the internal switch will be open.
			0*	Master is not requesting a lock on the downstream bus or giving up the lock if master had a lock on the downstream bus.
			1	Master is requesting a lock on the downstream bus.

Table 9. How PCA9641 selects winner

Master 0 priority	Master 1 priority	Last master granted	Result
0	0	none	Grant is given to Master 0
0	0	Master 0	Grant is given to Master 1
0	0	Master 1	Grant is given to Master 0
0	1	n/a	Grant is given to Master 1
1	0	n/a	Grant is given to Master 0
1	1	none	Grant is given to Master 1
1	1	Master 0	Grant is given to Master 1
1	1	Master 1	Grant is given to Master 0

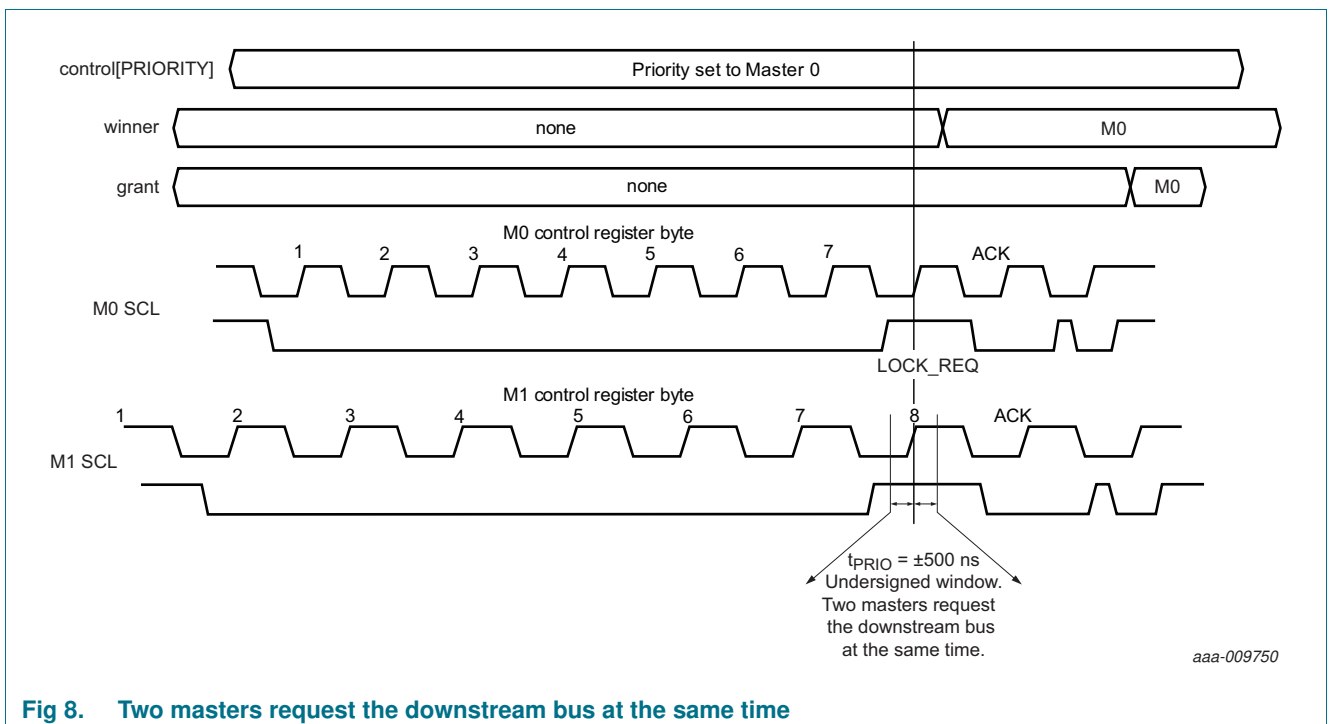

Fig 8. Two masters request the downstream bus at the same time

8.3 Register 2: Status register ([B2:B0] = 010b)

Table 10. STATUS - Status register (pointer address 02h) bit description

POR = 00h.

Legend: * default value

Bit	Symbol	Access	Value	Description
7	SDA_IO	R/W		SDA becomes I/O pin; master can read or write to this register bit. If master reads this bit, the value is the state of the downstream SDA pin. Zero value means SDA is LOW, and one means SDA pin is HIGH. When master writes '0' to this register bit, the downstream SDA pin will assert LOW. If master writes '1' to this register bit, the downstream SDA pin will be pulled HIGH. Remark: SDA becomes I/O pin only when BUS_CONNECT = 0 and LOCK_GRANT = 1.
			0*	When read, indicates the SDA pin of the downstream bus is LOW. When written, PCA9641 drives SDA pin of downstream bus LOW.
			1	When read, indicates the SDA pin of the downstream bus is HIGH. When written, PCA9641 drives SDA pin of the downstream bus HIGH.
6	SCL_IO	R/W		SCL becomes I/O pin; master can read or write to this register bit. If master reads this bit, the value is the state of the downstream SCL pin. Zero value means SCL is LOW, and one means SCL pin is HIGH. When master writes '0' to this register bit, the downstream SCL pin will assert LOW. If master writes '1' to this register bit, the downstream SCL pin will be pulled HIGH. Remark: SCL becomes I/O pin only when BUS_CONNECT = 0 and LOCK_GRANT = 1.
			0*	When read, shows the SCL pin of the downstream bus is LOW. When written, PCA9641 drives SCL pin of downstream bus LOW.
			1	When read, shows the SCL pin of the downstream bus is HIGH. When written, PCA9641 drives SCL pin of the downstream bus HIGH.

Table 10. STATUS - Status register (pointer address 02h) bit description ...continued

POR = 00h.

Legend: * default value

Bit	Symbol	Access	Value	Description
5	TEST_INT	W only		Test interrupt output pin; a master can send an interrupt to itself by writing '1' to this register bit. Writing '0' to this register bit has no effect. To clear this interrupt, master must write '1' to TEST_INT_INT in Interrupt Status register.
			0*	Normal operation
			1	Causes PCA9641 $\overline{\text{INT}}$ pin to go LOW if not masked by TEST_INT_INT in Interrupt Mask register. Allows this master to invoke its Interrupt Service Routine to handle housekeeping tasks.
4	MBOX_FULL	R only		This is a read-only status register bit. If this bit is '0', it indicates no data is available in the mail box. If it is '1', it indicates new data is available in the mail box.
			0*	No data is available for this master.
			1	Mailbox contains data for this master from the other master.
3	MBOX_EMPTY	R only		This is a read-only status register bit. If this bit is '0', it indicates other master mailbox is full, and this master cannot send more data to other master mailbox. If it is '1', it indicates other master is empty and this master can send data to other master mailbox.
			0*	Other master mailbox is full; wait until other master reads data.
			1	Other master mailbox is empty. Other master has read previous data and it is permitted to write new data.
2	BUS_HUNG	R only		This is a read-only status register bit. If this register bit is '0', it indicates the bus is in normal condition. If this bit is '1', it indicates the bus is hung. The hung bus means SDA signal is LOW and SCL signal does not toggle for more than 500 ms or SCL is LOW for 500 ms.
			0*	Normal operation
			1	Downstream bus hung; when SDA signal is LOW and SCL signal does not toggle for more than 500 ms or SCL is LOW for 500 ms.
1	BUS_INIT_FAIL	R only		This is a read-only status register bit. If this register bit is '0', it indicates the bus initialization function has passed. The downstream bus is in idle mode (SCL and SDA are HIGH). If this register bit is '1', it indicates the bus initialization function has failed. The SDA signal could be stuck LOW.
			0*	Normal operation
			1	Bus initialization has failed. SDA still LOW, the downstream bus cannot recover.

Table 10. STATUS - Status register (pointer address 02h) bit description ...continued

POR = 00h.

Legend: * default value

Bit	Symbol	Access	Value	Description
0	OTHER_LOCK	R only		This is a status read-only register bit. Other master lock status indicates the ownership between other master and the downstream bus. If this register bit is '1', the other master has owned the downstream bus. If this register bit is '0', the other master does not own the downstream bus.
			0*	The other master does not have a lock on the downstream bus.
			1	The other master has a lock on the downstream bus.

8.4 Register 3: Reserve Time register ([B2:B0] = 011b)

Reserve time is for when a master wants ownership of the downstream bus without interruption. It can reserve from 1 ms to 255 ms ownership of the downstream bus without interruption.

Table 11. RT - Reserve Time register (pointer address 03h) bit description

POR = 00h.

Bit	Symbol	Access	Value	Description
7 to 0	RES_TIME[7:0]	R/W		Reserve timer. Changes during LOCK_GRANT = 1 will have no effect.
			0	Disable timer or reserve without time limited.
			01h	1 ms
			:	:
			FFh	255 ms

Reserve time cannot be changed after LOCK_GRANT is one.

If a master requests the downstream bus with 00h in Reserve Time register, this master wants the downstream bus forever or until it gives up the bus by setting LOCK_REQ bit to zero.

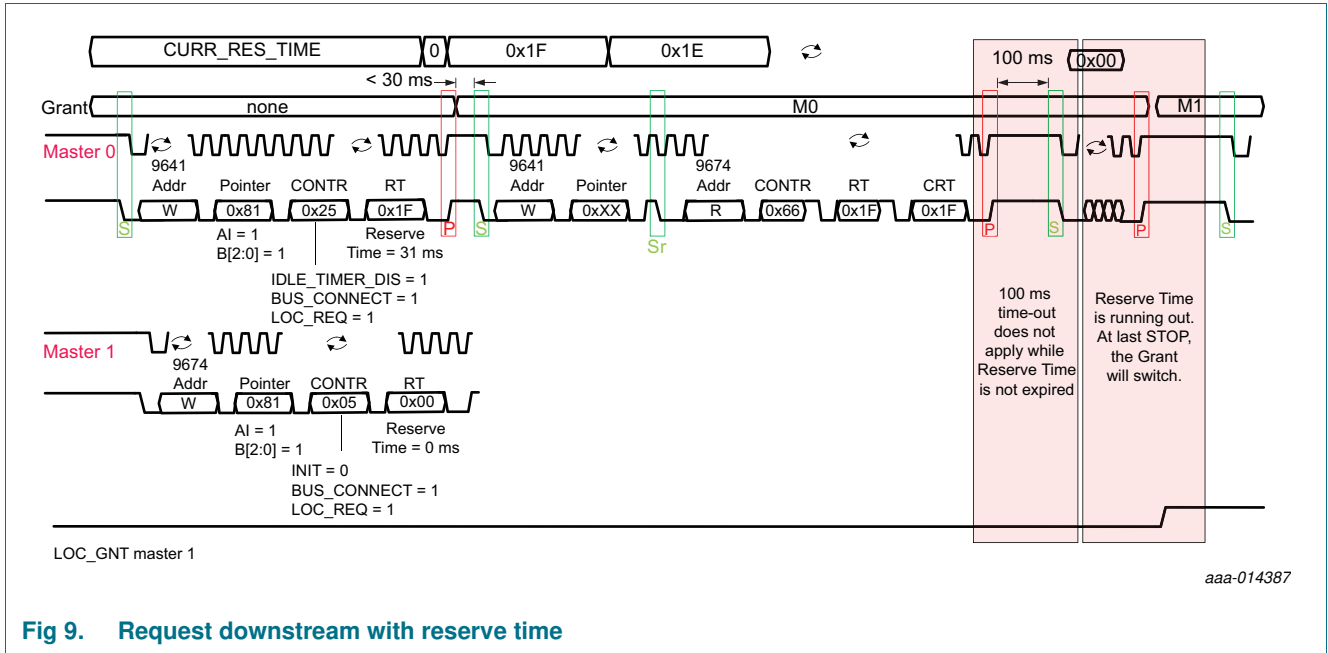

Fig 9. Request downstream with reserve time

8.5 Register 4: Interrupt Status register ([B2:B0] = 100b)

These interrupt status bits are sticky and will remain set until cleared by writing '1'.

The PCA9641 provides seven different types of interrupt.

Table 12. INT_STATUS - Interrupt status register (pointer address 04h) bit description
POR = 00h.

Bit	Symbol	Access	Value	Description
7	-			Reserved.
6	BUS_HUNG_INT	R only		Indicates to both masters that SDA signal is LOW and SCL signal does not toggle for more than 500 ms or SCL is LOW for 500 ms.
			0	No interrupt generated; normal operation.
			1	Interrupt generated; downstream bus cannot recover; when SDA signal is LOW and SCL signal does not toggle for more than 500 ms or SCL is LOW for 500 ms,
5	MBOX_FULL_INT	R/W		Indicates the mailbox has new mail.
			0	No interrupt generated; mailbox is not full.
			1	Interrupt generated; mailbox full.
4	MBOX_EMPTY_INT	R/W		Indicates the sent mail is empty, other master has read the mail.
			0	No interrupt generated; sent mail is not empty.
			1	Interrupt generated; mailbox is empty.
3	TEST_INT_INT	R/W		Indicates this master has sent an interrupt to itself.
			0	No interrupt generated; master has not set the TEST_INT bit in STATUS register.
			1	Interrupt generated; master activates its interrupt pin via the TEST_INT bit in STATUS register.
2	LOCK_GRANT_INT	R/W		Indicates the master has a lock (ownership) on the downstream bus.
			0	No interrupt generated; this master does not have a lock on the downstream bus.
			1	Interrupt generated; this master has a lock on the downstream bus.
1	BUS_LOST_INT	R/W		Indicates the master has involuntarily lost the ownership of the downstream bus.
			0	No interrupt generated; this master is controlling the downstream bus.
			1	Interrupt generated; this master has involuntarily lost the control of the downstream bus.
0	INT_IN_INT	R/W		Indicates that there is an interrupt from the downstream bus to both the granted and non-granted masters.
			0	No interrupt on interrupt input pin $\overline{\text{INT_IN}}$.
			1	Interrupt on interrupt input pin $\overline{\text{INT_IN}}$.

8.6 Register 5: Interrupt Mask register ([B2:B0] = 101b)

Table 13. INT_MSK - Interrupt Mask register (pointer address 05h) bit description
POR = 7Fh.

Bit	Symbol	Access	Value	Description
7	-			Reserved.
6	BUS_HUNG_MSK	R/W	0	Enable output interrupt when BUS_HUNG function is set.
			1	Disable output interrupt when BUS_HUNG function is set.
5	MBOX_FULL_MSK	R/W	0	Enable output interrupt when MBOX_FULL function is set.
			1	Disable output interrupt when MBOX_FULL function is set.
4	MBOX_EMPTY_MSK	R/W	0	Enable output interrupt when MBOX_EMPTY function is set.
			1	Disable output interrupt when MBOX_EMPTY function is set.
3	TEST_INT_MSK	R/W	0	Enable output interrupt when TEST_INT function is set.
			1	Disable output interrupt when TEST_INT function is set.
2	LOCK_GRANT_MSK	R/W	0	Enable output interrupt when LOCK_GRANT function is set.
			1	Disable output interrupt when LOCK_GRANT function is set.
1	BUS_LOST_MSK	R/W	0	Enable output interrupt when BUS_LOST function is set.
			1	Disable output interrupt when BUS_LOST function is set.
0	INT_IN_MSK	R/W	0	Enable output interrupt when INT_IN function is set.
			1	Disable output interrupt when INT_IN function is set.

8.7 Registers 6 and 7: MB registers ([B2:B0] = 110b and 111b)

Table 14. SMB - Shared Mail Box registers (pointer addresses 06h, 07h) bit description
POR = 00h.

Address	Bit	Symbol	Access	Description
06h	7 to 0	MB_LO[7:0]	R/W	Low 8 bits of the mail box.
07h	7 to 0	MB_HI[7:0]	R/W	High 8 bits of the mail box.

8.8 Operating cycle of the downstream bus

8.8.1 Request the downstream bus

When a master seeks control of the bus by requesting its I²C-bus channel to the PCA9641 registers, it must write to the Control register (CONTR, 01h) and Reserve Time register (RT, 03h) optional. LOCK_REQ bit and RT[7:0] allow the master to take control of the bus in a period of RES_TIME without interrupting.

While master 0 is working on the downstream bus, master 1 can request the downstream bus by writing to LOCK_REQ bit in CONTR register and RT register. When the downstream bus is free and RES_TIME is expired, master 1 will have control of the downstream bus.

If Reserve Time is set to 0, it will disable the timer counter. That means the master requests the downstream bus forever or until it gives up the bus.

8.8.2 Acquire the downstream bus

After the master wrote to LOCK_REQ bit and RT register, it must poll LOCK_GRANT bit in CONTR register or wait for interrupt signal ($\overline{\text{INTx}}$ pin) if LOCK_GRANT_MSK bit is set in INT_MSK register for the ownership of the downstream bus.

When LOCK_GRANT bit is one, this master has full control of the downstream bus.

To start communication with downstream slave devices, master must connect to downstream bus by setting BUS_CONNECT = 1.

8.8.3 Give up the downstream bus

The RES_TIME starts countdown after LOCK_GRANT becomes one. When the RES_TIME becomes zero and the I²C-bus is free (SCL_SLAVE and SDA_SLAVE are HIGH) after STOP condition, PCA9641 will clear the LOCK_GRANT bit.

If a master requests the downstream bus with RES_TIME = 0, it must write zero to LOCK_REQ bit to give up its control.

9. Arbitration

9.1 Rules

1. If a master keeps its request asserted after its grant, the master will indefinitely hold the bus.
 - If the bus goes IDLE for 100 ms, it will be disconnected only if the idle time-out function is enabled and the reserve timer has expired.
2. If a master removes its request, then that master will lose its grant.
 - If the other master is requesting the bus, it will be granted.
 - If no master is requesting the bus, PCA9641 will disconnect from both.
3. If a master sets the reserve timer before its grant, the timer will clear its request when it expires.
 - This timer gives a 1 ms to 255 ms window for locking the bus. When the timer expires, it clears the master's request and follows Step [2](#).
 - If the bus is idle for 100 ms and the reserve timer has not expired, the grant will **not** be lost.
 - If the master clears its request and the reserve timer has not expired, the grant will be lost.
4. If both masters request the grant at the same time (close), the winner will be determined as follows:
 - The first master to set the request bit in the register wins. START does not matter, and nothing else really matters as the masters might have different clock frequencies, etc. The master might be doing a burst write with an address rollover, making the control register the last byte it writes. However, if the bit is set in the control register first, it wins.
 - The action of the grant is applied when the winning master's transaction is terminated with a STOP. (It is not OK to do a Re-START when requesting the bus; before accessing the downstream slaves, master must issue a STOP.)
 - If both masters request at the exact same time, and logic cannot determine a winner, the control register priority bit determines which master to give the grant to. See [Section 8.2](#).
5. A write to the control register for a REQUEST will always be answered with an ACK.
 - The master must poll the control register or use the interrupts to determine when the grant is awarded.

9.2 Disconnect events

The following events cause a master to disconnect condition to occur, assuming the conditions from the previous section are satisfied to allow the grant to be removed and the downstream bus to be disconnected.

1. STOP (ideal, this is the cleanest way).
2. Bus IDLE for 100 ms (not ideal).
3. Writing 0 to LOCK_REQ.

10. State machines

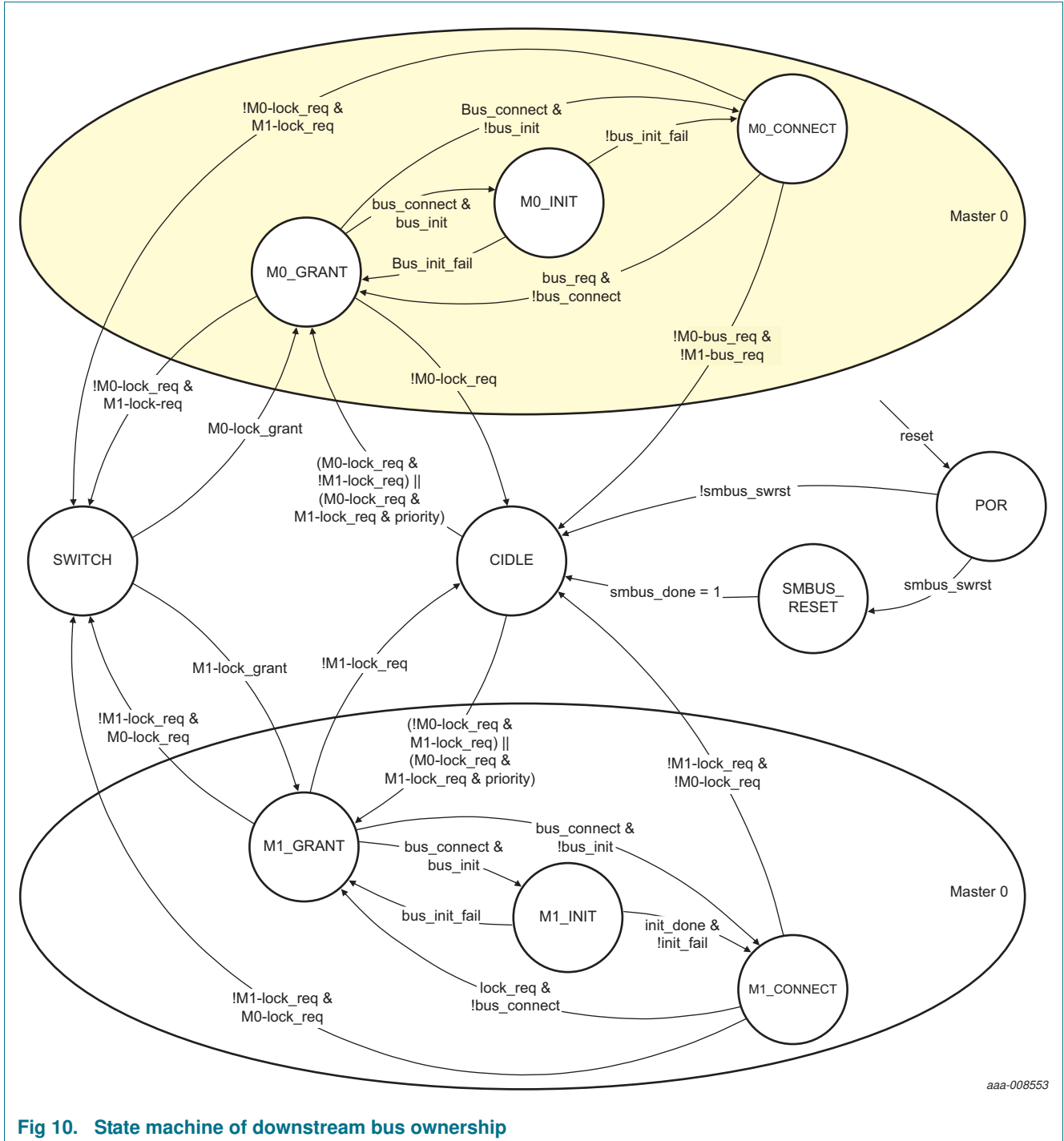

Fig 10. State machine of downstream bus ownership

11. Request grant examples

In the waveform shown in [Figure 11](#), Master 0 initiated a START first. Master 1 was at a higher clock speed and wrote the request bit first, so Master 1 won the arbitration.

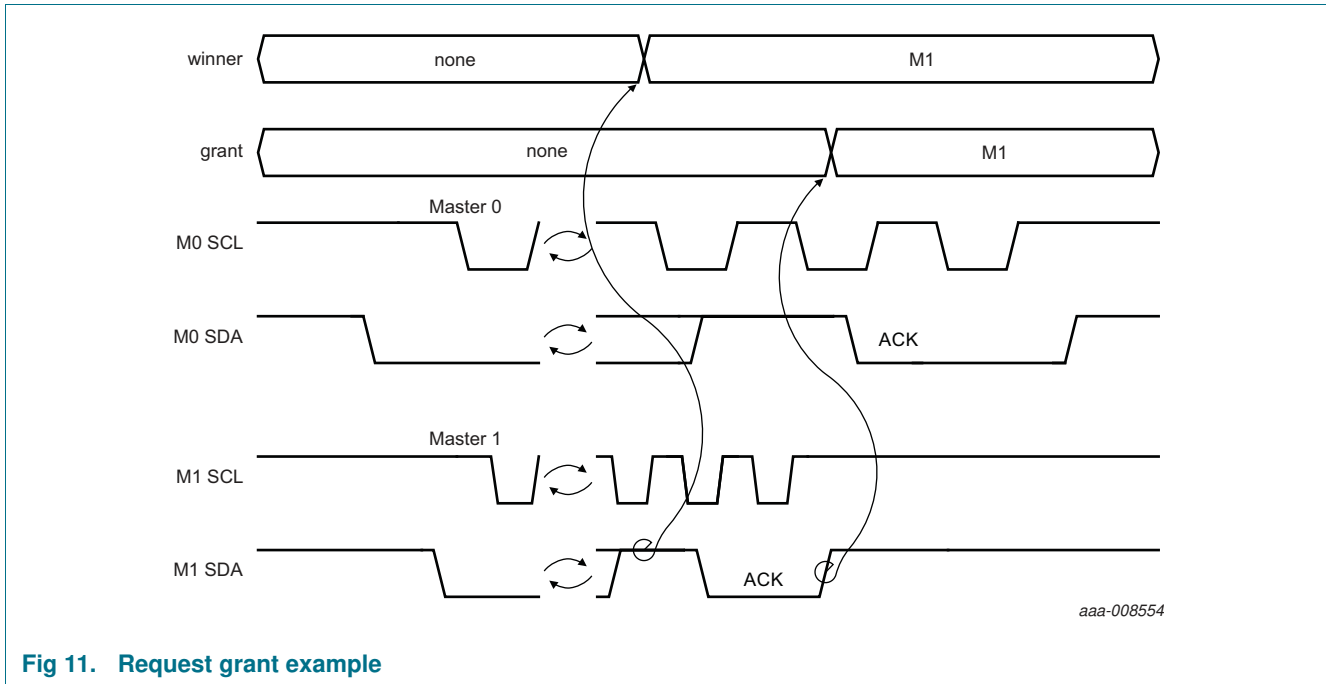

Fig 11. Request grant example

The effects of the arbitration do not take effect until the winning master issues a STOP condition. If the winning master were to continue to write to the next register using auto-incrementing addresses, it would delay the grant until the STOP. The master has 'won' the arbitration, though.

Two masters request the bus at the same time (close enough that the logic cannot tell the difference). See [Figure 8](#) for the waveform. In this case the PRIORITY bits are used to determine the winner. The truth table, [Table 9](#), is for winner selection.

12. Characteristics of the I²C-bus

The information in this section pertains to both M0 and M1 I²C-bus interfaces.

The I²C-bus interface is used to access the device programmable registers. This interface runs as Fast-mode Plus (Fm+) speeds with a general call software reset. The I²C core is composed of the I²C State Machine, shift register, and the start/stop detection logic.

The I²C-bus is for 2-way, 2-line communication between different ICs or modules. The two lines are a serial data line (SDA) and a serial clock line (SCL). Both lines must be connected to a positive supply via a pull-up resistor when connected to the output stages of a device. Data transfer may be initiated only when the bus is not busy.

12.1 Bit transfer

One data bit is transferred during each clock pulse. The data on the SDA line must remain stable during the HIGH period of the clock pulse as changes in the data line at this time will be interpreted as control signals (see [Figure 12](#)).

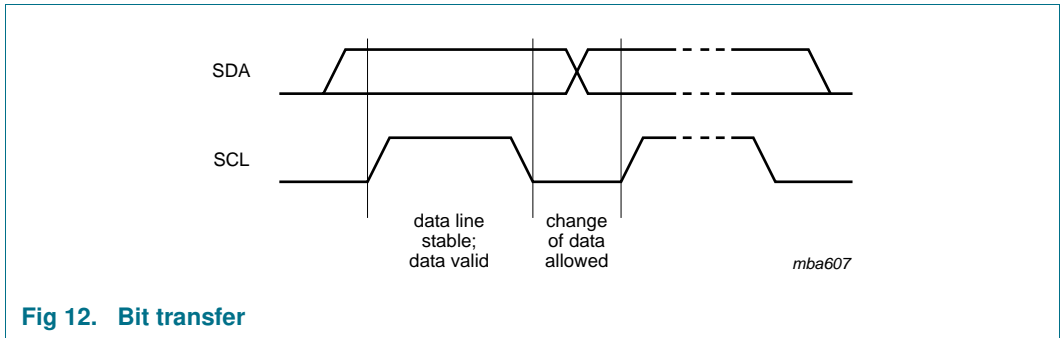

Fig 12. Bit transfer

12.2 START and STOP conditions

Both data and clock lines remain HIGH when the bus is not busy. A HIGH-to-LOW transition of the data line, while the clock is HIGH is defined as the START condition (S). A LOW-to-HIGH transition of the data line while the clock is HIGH is defined as the STOP condition (P) (see [Figure 13](#)).

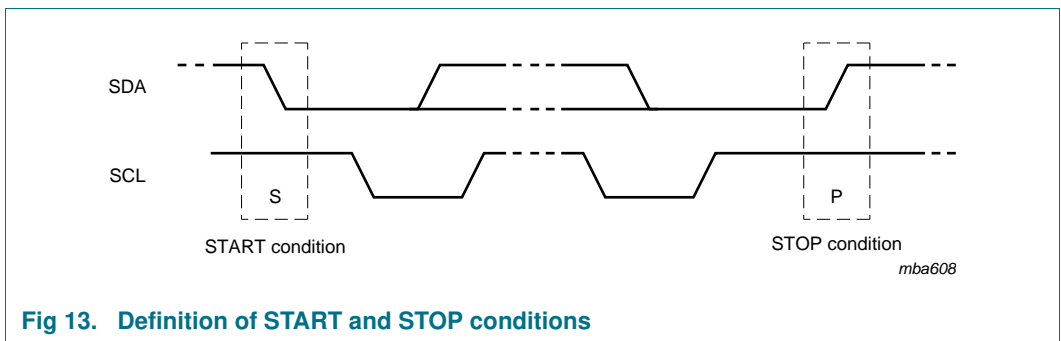

Fig 13. Definition of START and STOP conditions

12.3 System configuration

A device generating a message is a 'transmitter', a device receiving is the 'receiver'. The device that controls the message is the 'master' and the devices which are controlled by the master are the 'slaves' (see [Figure 14](#)).

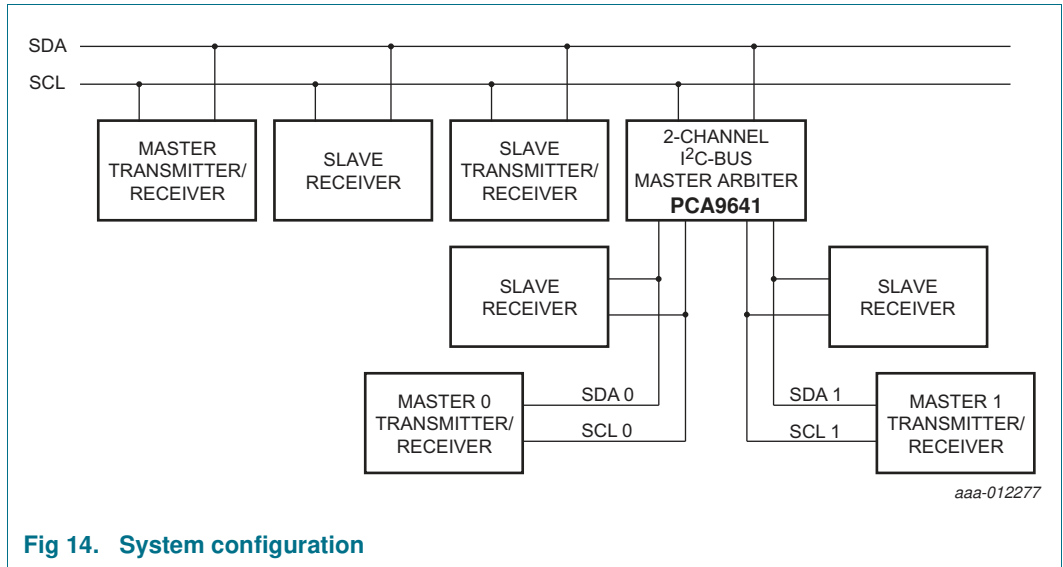

Fig 14. System configuration

12.4 Acknowledge

The number of data bytes transferred between the START and the STOP conditions from transmitter to receiver is not limited. Each byte of eight bits is followed by one acknowledge bit. The acknowledge bit is a HIGH level put on the bus by the transmitter, whereas the master generates an extra acknowledge related clock pulse.

A slave receiver which is addressed must generate an acknowledge after the reception of each byte. Also a master must generate an acknowledge after the reception of each byte that has been clocked out of the slave transmitter. The device that acknowledges has to pull down the SDA line during the acknowledge clock pulse, so that the SDA line is stable LOW during the HIGH period of the acknowledge related clock pulse; set-up and hold times must be taken into account.

A master receiver must signal an end of data to the transmitter by not generating an acknowledge on the last byte that has been clocked out of the slave. In this event, the transmitter must leave the data line HIGH to enable the master to generate a STOP condition.

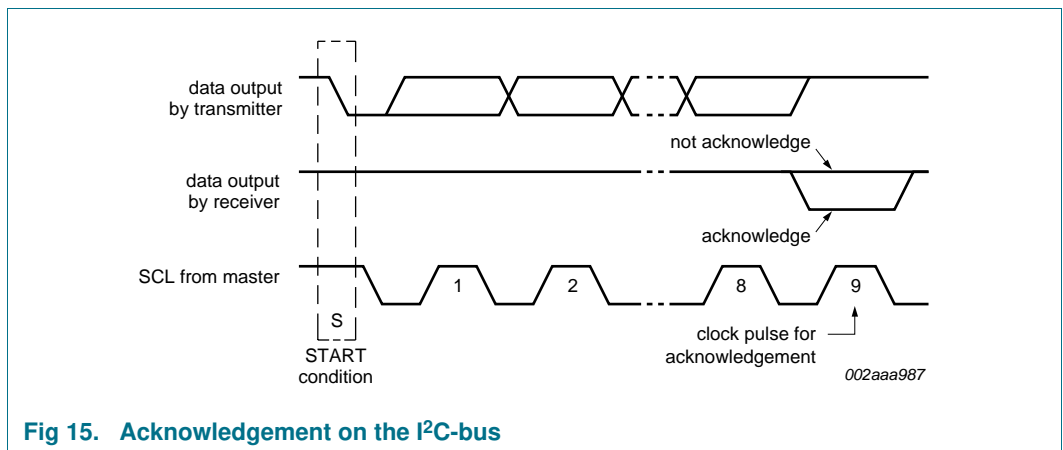

Fig 15. Acknowledgement on the I²C-bus

12.5 Bus transactions

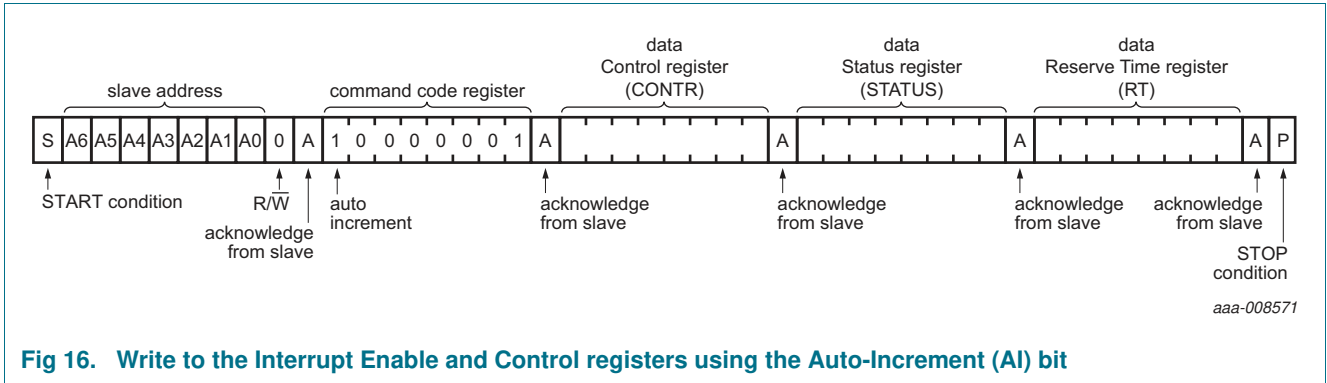

Fig 16. Write to the Interrupt Enable and Control registers using the Auto-Increment (AI) bit

12.6 Auto-increment

Writing to each register carries an overhead of a total of 3 bytes: slave address, command, and data. Auto-increment allows the user to send or receive data continuously where the slave will auto-increment and wrap around on the registers.

The auto-increment is bit 8 of the command byte (see [Figure 5](#)).

By setting the AI bit to 1, the master can send or read N data bytes to or from incrementing addresses that wrap around to 0x0. For example, a write to register address 0x4 will write data byte 1 to address 0x4, data byte 2 to address 0x5, data byte 3 to address 0x6, data byte 4 to address 0x7, data byte 5 to address 0x0, data byte 6 to address 0x1, data byte 7 to address 0x2 and data byte 8 to address 0x3. The read occurs in much the same way. When write to read register only, the write will not affect the value.

The master stops an auto-increment write by sending a STOP bit after the final slave ACK. The master stops a read by NACKing the final byte and sending a STOP bit.

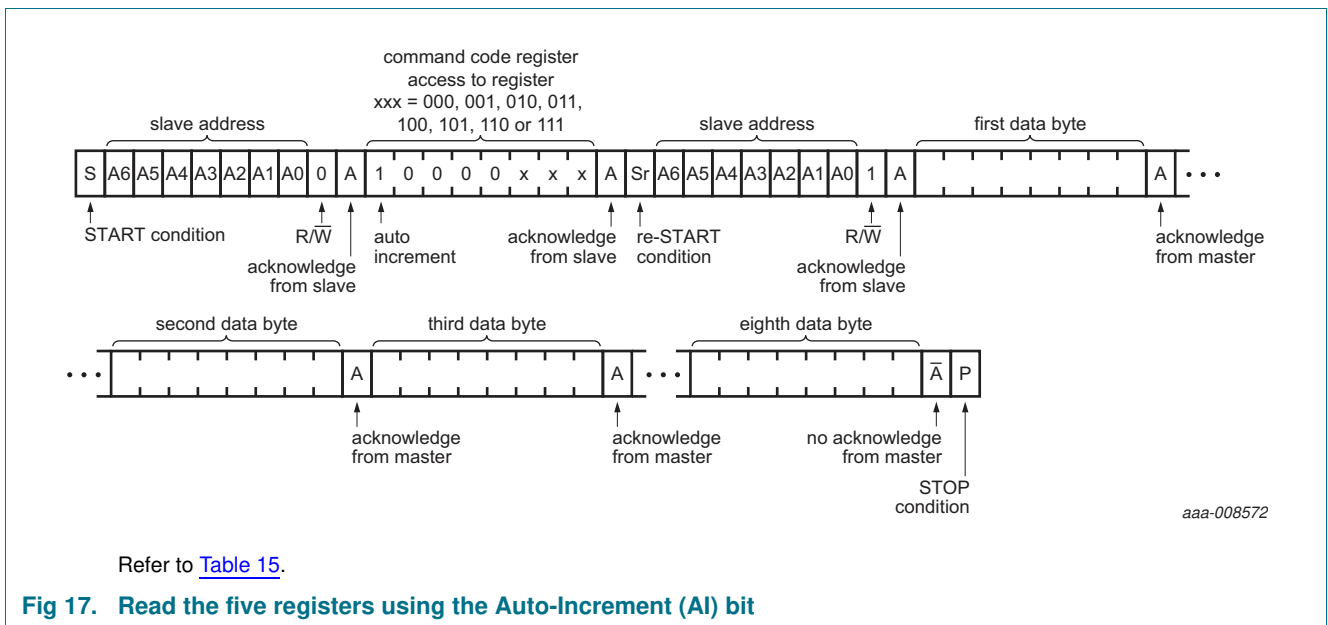

Fig 17. Read the five registers using the Auto-Increment (AI) bit

Remark: If an eighth data byte is read, the first register will be accessed.

Table 15. Read/write the registers using Auto-Increment

Command code	First data byte	Second data byte	Third data byte	Fourth data byte	Fifth data byte	Sixth data byte	Seventh data byte	Eighth data byte
1000 0000	ID	CONTR	STATUS	RT	INT_STATUS	INT_MASK	MB_LO	MB_HI
1000 0001	CONTR	STATUS	RT	INT_STATUS	INT_MASK	MB_LO	MB_HI	ID
1000 0010	STATUS	RT	INT_STATUS	INT_MASK	MB_LO	MB_HI	ID	CONTR
1000 0011	RT	INT_STATUS	INT_MASK	MB_LO	MB_HI	ID	CONTR	STATUS
1000 0100	INT_STATUS	INT_MASK	MB_LO	MB_HI	ID	CONTR	STATUS	RT

Table 15. Read/write the registers using Auto-Increment ...continued

Command code	First data byte	Second data byte	Third data byte	Fourth data byte	Fifth data byte	Sixth data byte	Seventh data byte	Eighth data byte
1000 0101	INT_MASK	MB_LO	MB_HI	ID	CONTR	STATUS	RT	INT_STATUS
1000 0110	MB_LO	MB_HI	ID	CONTR	STATUS	RT	INT_STATUS	INT_MASK
1000 0111	MB_HI	ID	CONTR	STATUS	RT	INT_STATUS	INT_MASK	MB_LO

13. General call software reset

The Software Reset Call allows all the devices in the I²C-bus to be reset to the power-up state value through a specific formatted I²C-bus command. To be performed correctly, it implies that the I²C-bus is functional and that there is no device hanging the bus.

The Software Reset sequence is defined as following:

1. A START command is sent by the I²C-bus master.
2. The reserved General Call I²C-bus address '0000 000' with the R/W bit set to 0 (write) is sent by the I²C-bus master.
3. The device(s) acknowledge(s) after seeing the General Call address '0000 0000' (00h) only. If the R/W bit is set to 1 (read), no acknowledge is returned to the I²C-bus master.
4. Once the General Call address has been sent and acknowledged, the master sends 1 byte. The value of the byte must be equal to 06h. The device acknowledges this value only. If the byte is not equal to 06h, the device does not acknowledge it. If more than 1 byte of data is sent, the device does not acknowledge any more.
5. Once the right byte has been sent and correctly acknowledged, the master sends a STOP command to end the Software Reset sequence: the slave device then resets to the default value (power-up value) and is ready to be addressed again within the specified bus free time. If the master sends a Repeated START instead, no reset is performed.
6. PCA9641 will issue the bus recovery procedure.

The I²C-bus master must interpret a non-acknowledge from the slave device (at any time) as a 'Software Reset Abort'. Slave device does not initiate a reset of its registers.

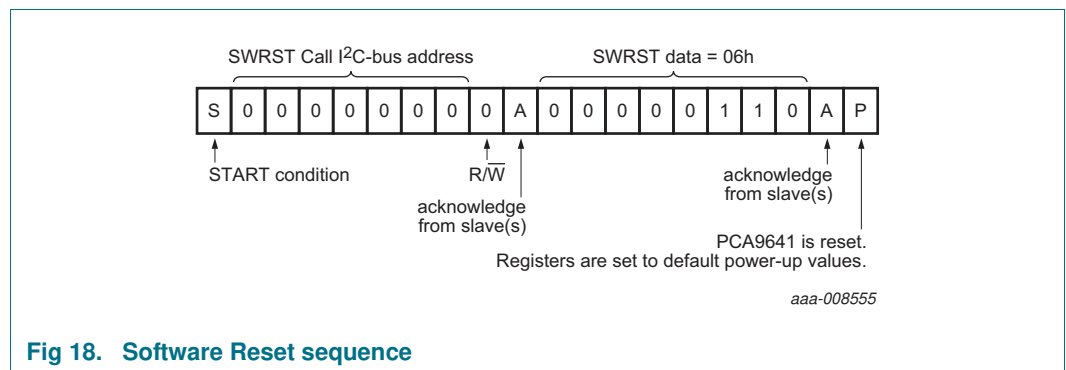

Fig 18. Software Reset sequence

14. Device ID (PCA9641 ID field)

The Device ID field is a 3-byte read-only (24 bits) word giving the following information:

- The first 12 bits are for the manufacturer name, unique per manufacturer (for example, NXP).
- The next 9 bits are for the part identification, assigned by manufacturer.
- The last 3 bits are for the die revision, assigned by manufacturer (for example, Rev X).

The Device ID is read-only, hardwired in the device and can be accessed as follows:

1. START command.
2. The master sends the Reserved Device ID I²C-bus address '1111 100' with the R/W bit set to 0 (write).
3. The master sends the I²C-bus slave address of the slave device it needs to identify. The LSB is a 'Don't care' value. Only one device must acknowledge this byte (the one that has the I²C-bus slave address).
4. The master sends a Re-START command.

Remark: A STOP command followed by a START command will reset the slave state machine and the Device ID read cannot be performed.

Remark: A STOP command or a Re-START command followed by an access to another slave device will reset the slave state machine and the Device ID read cannot be performed.

5. The master sends the Reserved Device ID I²C-bus address '1111 100' with the R/W bit set to 1 (read).
6. The device ID read can be done, starting with the 12 manufacturer bits (first byte + 4 MSB of the second byte), followed by the 9 part identification bits and then the 3 die revision bits (3 LSB of the third byte).
7. The master ends the reading sequence by NACKing the last byte, thus resetting the slave device state machine and allowing the master to send the STOP command.

Remark: The reading of the Device ID can be stopped anytime by sending a NACK command.

Remark: If the master continues to ACK the bytes after the third byte, the PCA9641 rolls back to the first byte and keeps sending the Device ID sequence until a NACK has been detected.

Table 16. PCA9641 ID field

Byte 3						Byte 2						Byte 1											
0	0	0	0	0	0	0	0	0	0	0	1	0	0	0	0	0	0	1	1	1	0	0	0
Bits [23:11]						Bits [10:3]						Bits [2:0]											
Manufacturer ID						Part ID						Revision											

15. Shared mailbox

Shared mailbox contains two 8-bit bidirectional mailboxes used for communication between the two masters. Each master has MB_HI and MB_LO registers on their address map. The mailbox uses a MBOX_FULL and MBOX_EMPTY status to assist in the flow of data and prevent data loss or corruption.

When a master is sending data via the mailbox, it must check the MBOX_EMPTY status bit. If the MBOX_EMPTY status bit is zero (not EMPTY), then it contains data for the other master that has not been read, and writing at this time would result in data loss/corruption. When the MBOX_EMPTY status bit is one (EMPTY), the master may write to the mailbox. In order to send data through the mailbox, the master must write the entire 16 bits, starting with MB_LO and finishing with MB_HI. If the mailbox is written in reverse order, it will not activate the FULL flag on the receiving master. Once the mailbox has been written, the transmitting master's MBOX_EMPTY status bit is cleared (0), and the receiving master's MBOX_FULL status bit is set (1).

When a master's MBOX_FULL status bit is set, it means that there is data in the mailbox from the other master that has not been read. The master may read the mailbox in any order, but the FULL flag will not be cleared until both MB_LO and MB_HI have been read. When they have been read, the sending master's MBOX_EMPTY status bit is set, indicating the data has been read and the mailbox is ready for more data. When they have been read, the receiving master's MBOX_FULL status bit is cleared, indicating there is no new data in the mailbox to be read.

When a master **writes** the mailbox registers, it is sending data to the other master's mailbox. When a master **reads** the mailbox, it is reading from its own mailbox. It is not possible to write data into the mailbox and read it back.

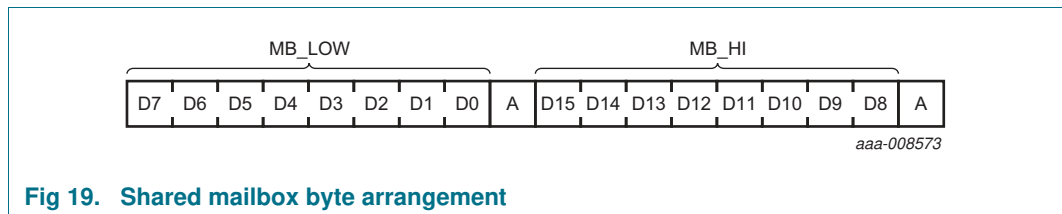

Fig 19. Shared mailbox byte arrangement

16. Application design-in information

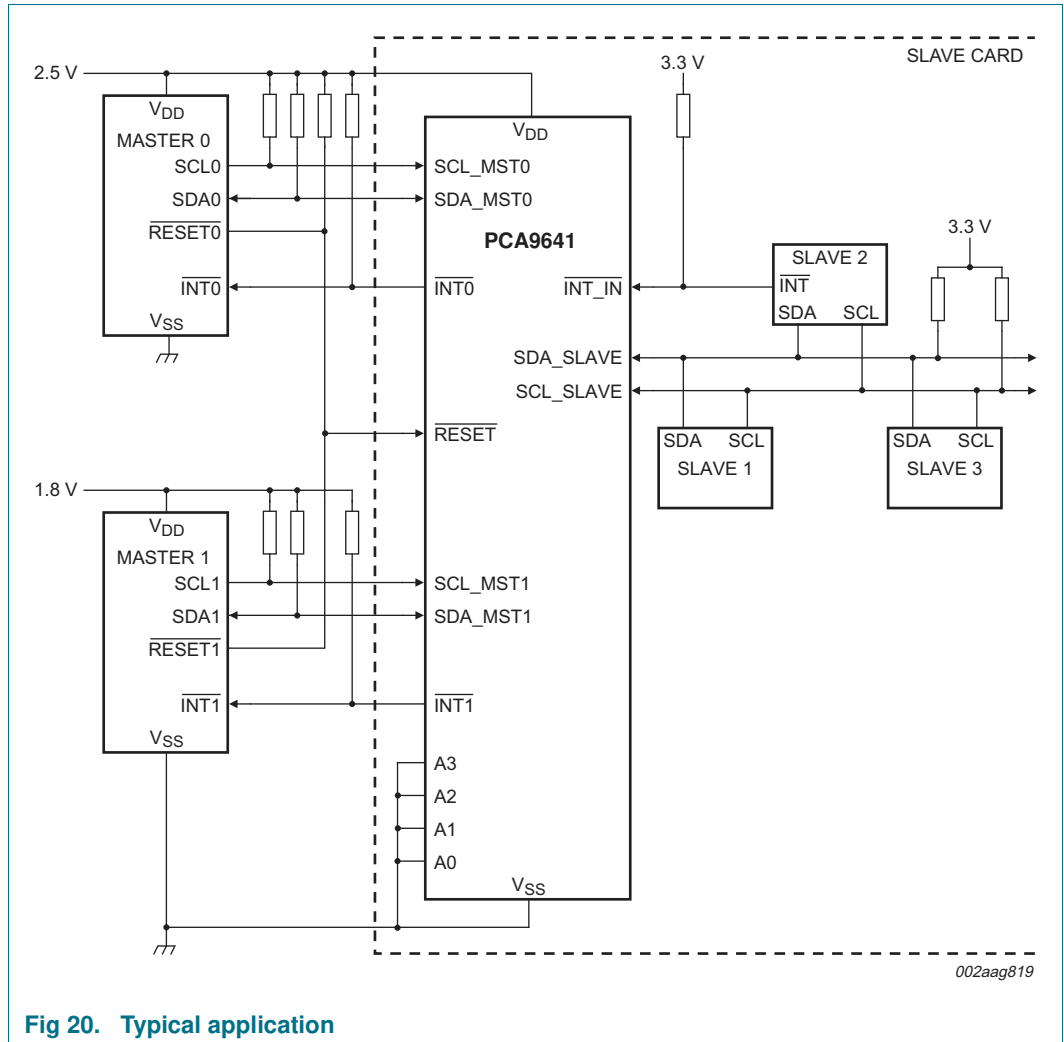

Fig 20. Typical application

16.1 Specific applications

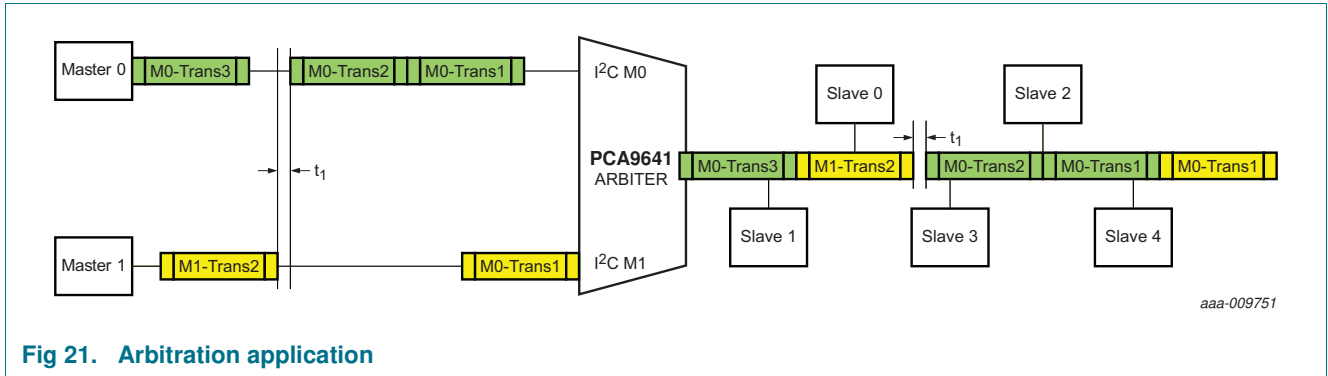

Fig 21. Arbitration application

The PCA9641 is a 2-to-1 I²C-bus master arbiter designed for dual masters sharing the same downstream slave devices. Any master can request the downstream bus at any time and PCA9641 will let the master know when it is its turn to control the downstream bus. The master will not overwrite the other master's transactions, and no advance software is needed. In high reliability I²C-bus applications, the PCA9641 will switch between masters when the downstream bus is free and clear. If the downstream bus hangs, PCA9641 will remotely recover the bus by multiple ways, such as smart initialization, SMBus time-out, remote toggling of SCL and SDA.

16.2 High reliability systems

In a typical multipoint application, shown in [Figure 22](#), the two masters (for example, primary and back-up) are located on separate I²C-buses that connect to multiple downstream I²C-bus slave cards/devices via a PCA9641 for non-hot swap applications to provide high reliability of the I²C-bus.

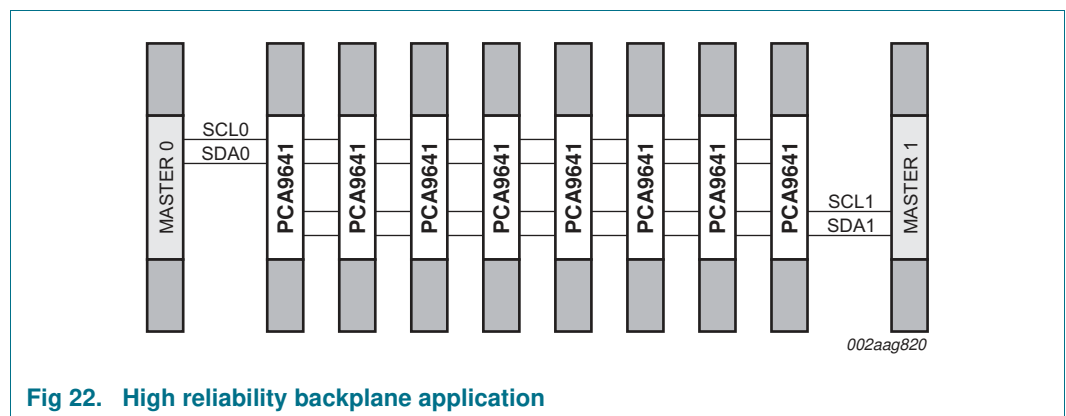

Fig 22. High reliability backplane application

I²C-bus commands are sent via the primary or back-up master and either master can take command of the I²C-bus. Either master at any time can gain control of the slave devices if the other master is disabled or removed from the system. The failed master is isolated from the system and will not affect communication between the on-line master and the slave devices located on the cards.

For even higher reliability in multipoint backplane applications, two dedicated masters can be used for every card as shown in [Figure 23](#).

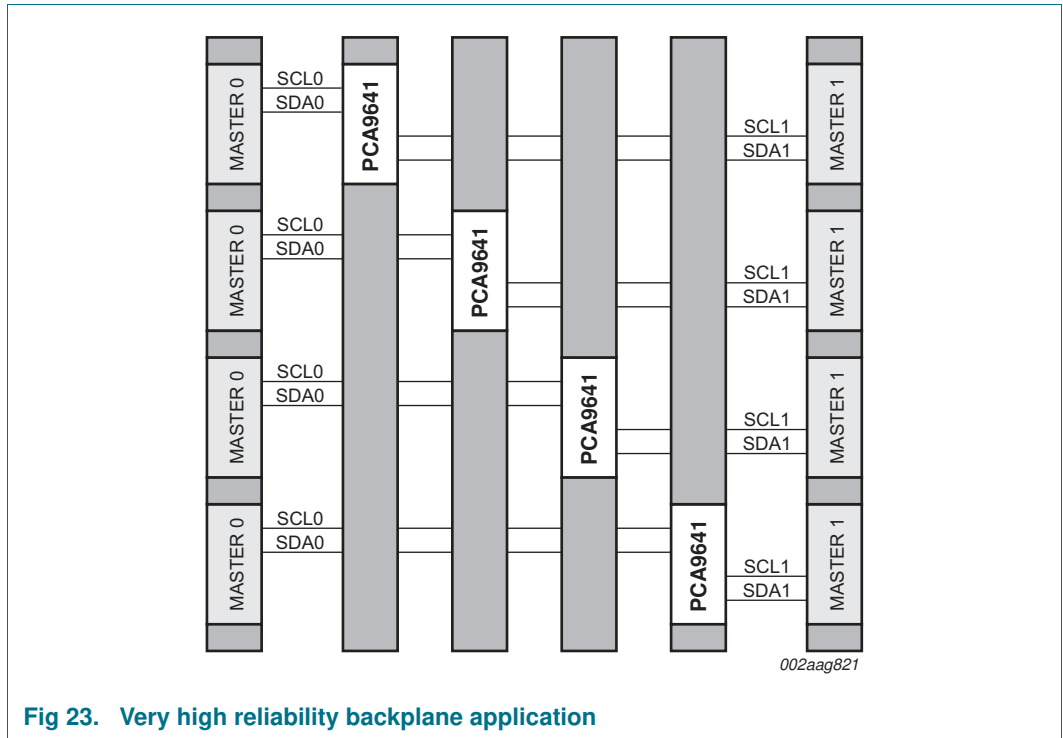

Fig 23. Very high reliability backplane application

16.3 Masters with shared resources

Some masters may not be multi-master capable or some masters may not work well together and continually lock up the bus. The PCA9641 can be used to separate the masters, as shown in Figure 24, but still allow shared access to slave devices, such as Field Replaceable Unit (FRU) EEPROMs or temperature sensors.

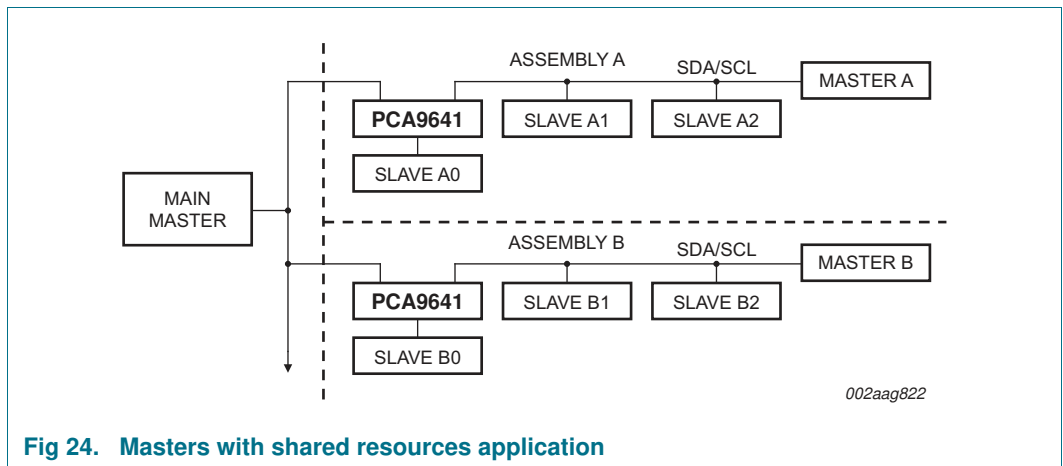

Fig 24. Masters with shared resources application

16.4 Gatekeeper multiplexer

The PCA9641 can act as a gatekeeper multiplexer in applications where there are multiple I²C-bus devices with the same fixed address (for example, EEPROMs with address of 'Z' as shown in [Figure 25](#)) connected in a multipoint arrangement to the same bus master by using one PCA9641 per card/device. Since each PCA9641 has its own unique address (for example, 'A', 'B', 'C', and so on), the EEPROMs can be connected to the master, one at a time, by connecting one PCA9641 (Master 0 position) while keeping the rest of the cards/devices isolated (off position).

The alternative, shown with dashed lines, is to use a PCA9548A 1-to-8 channel switch on the master card and run eight I²C-bus devices, one to each EEPROM card, to multiplex the master to each card. The number of card pins used is the same in either case, but there are seven fewer pairs of SDA/SCL traces on the printed-circuit board if the PCA9641 is used.

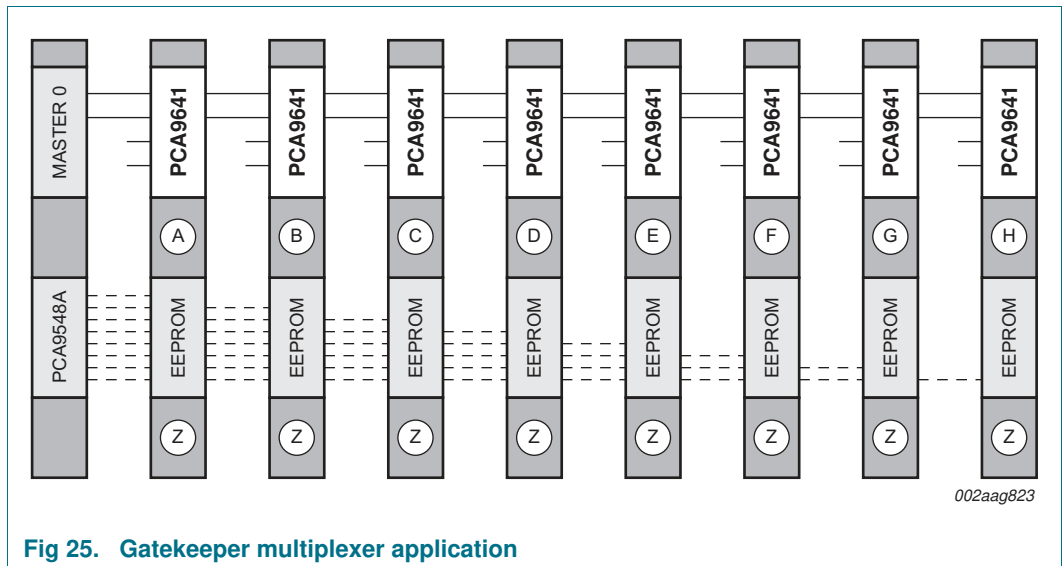

Fig 25. Gatekeeper multiplexer application

16.5 Bus initialization/recovery to initialize slaves without hardware reset

If the I²C-bus is hung, I²C-bus devices without a hardware reset pin (for example, Slave 1 and Slave 2 in Figure 26) can be isolated from the master by the PCA9641. The PCA9641 disconnects the hung bus if IDLE_TIMER_DIS was set or over 500 ms, restoring the master's control of the rest of the bus (for example, Slave 0). The bus master can then command the PCA9641 to send nine clock pulses/STOP condition to reset the downstream I²C-bus devices before they are reconnected to the master or leave the downstream devices isolated.

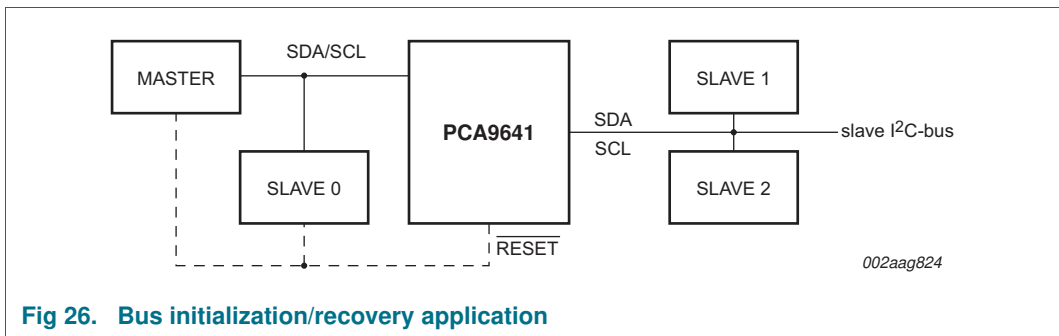

Fig 26. Bus initialization/recovery application

16.6 Power-on reset requirements

In the event of a glitch or data corruption, PCA9641 can be reset to its default conditions by using the power-on reset feature. Power-on reset requires that the device go through a power cycle to be completely reset. This reset also happens when the device is powered on for the first time in an application.

The two types of power-on reset are shown in Figure 27 and Figure 28.

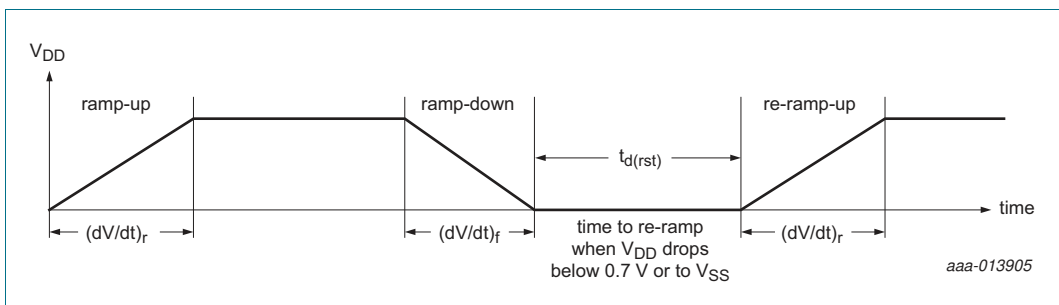

Fig 27. V_{DD} is lowered below 0.7 V or 0 V and then ramped up to V_{DD}

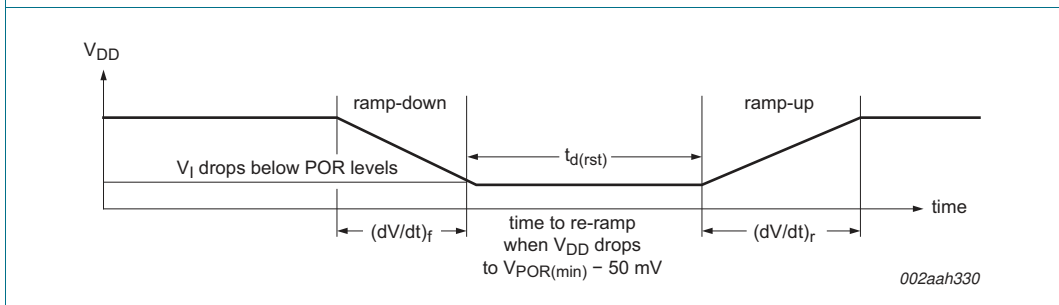

Fig 28. V_{DD} is lowered below the POR threshold, then ramped back up to V_{DD}

[Table 17](#) specifies the performance of the power-on reset feature for PCA9641 for both types of power-on reset.

Table 17. Recommended supply sequencing and ramp rates

$T_{amb} = 25\text{ }^{\circ}\text{C}$ (unless otherwise noted). Not tested; specified by design.

Symbol	Parameter	Condition	Min	Typ	Max	Unit
$(dV/dt)_f$	fall rate of change of voltage	Figure 27	0.1	-	2000	ms
$(dV/dt)_r$	rise rate of change of voltage	Figure 27	0.1	-	2000	ms
$t_{d(rst)}$	reset delay time	Figure 27 ; re-ramp time when V_{DD} drops to V_{SS}	1	-	-	μs
		Figure 28 ; re-ramp time when V_{DD} drops to $V_{POR(min)} - 50\text{ mV}$	1	-	-	μs
$\Delta V_{DD(gl)}$	glitch supply voltage difference	Figure 29	[1]	-	1	V
$t_{w(gl)VDD}$	supply voltage glitch pulse width	Figure 29	[1]	-	10	μs
$V_{POR(trip)}$	power-on reset trip voltage	falling V_{DD}	0.7	-	-	V
		rising V_{DD}	-	-	1.8	V
$t_{REC;STA}$	recovery time to START condition	refer to Figure 33	155	-	-	μs

[1] Glitch width and ΔV_{DD} voltage that will not cause a functional disruption.

Glitches in the power supply can also affect the power-on reset performance of this device. The glitch width ($t_{w(gl)VDD}$) and glitch height ($\Delta V_{DD(gl)}$) are dependent on each other. The bypass capacitance, source impedance, and device impedance are factors that affect power-on reset performance. [Figure 29](#) and [Table 17](#) provide more information on how to measure these specifications.

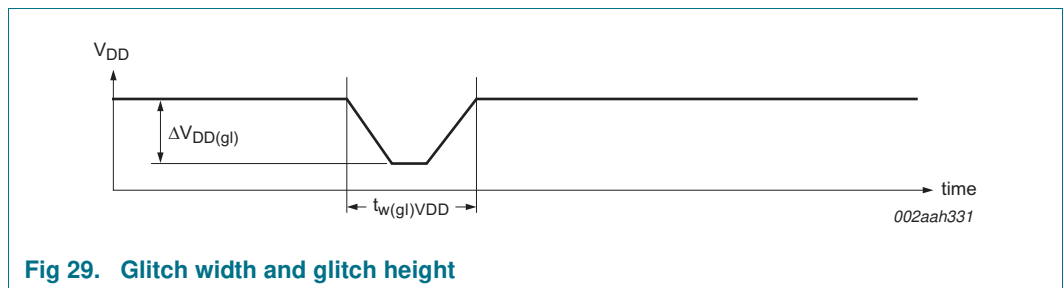

Fig 29. Glitch width and glitch height

V_{POR} is critical to the power-on reset. V_{POR} is the voltage level at which the reset condition is released and all the registers and the I²C-bus/SMBus state machine are initialized to their default states. The value of V_{POR} differs based on the V_{DD} being lowered to or from 0 V. [Figure 30](#) and [Table 17](#) provide more details on this specification.

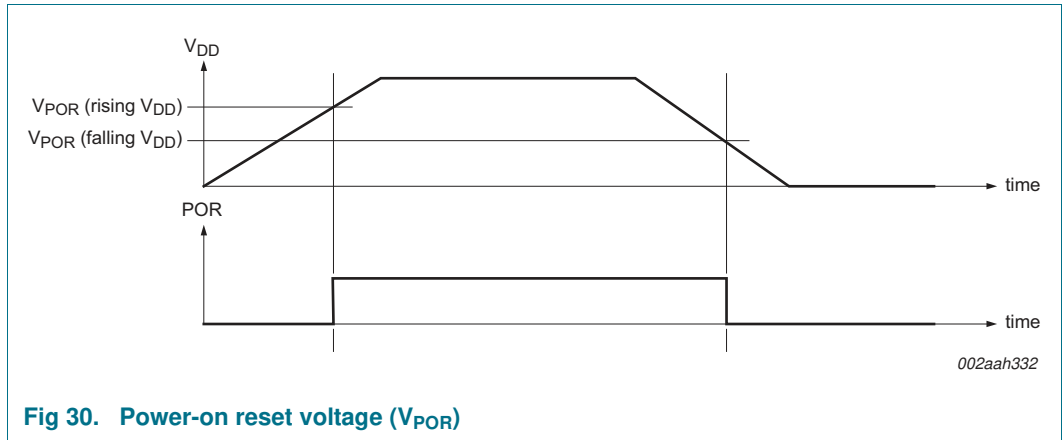

Fig 30. Power-on reset voltage (V_{POR})

17. Limiting values

Table 18. Limiting values

In accordance with the Absolute Maximum Rating System (IEC 60134). Voltages are referenced to V_{SS} (ground = 0 V).^[1]

Symbol	Parameter	Conditions	Min	Max	Unit
V_{DD}	supply voltage		-0.5	+4.0	V
V_I	input voltage		-0.5	+4.0	V
I_I	input current		-20	+20	mA
I_O	output current		-25	+25	mA
I_{DD}	supply current		-100	+100	mA
I_{SS}	ground supply current		-100	+100	mA
P_{tot}	total power dissipation		-	400	mW
T_{stg}	storage temperature		-60	+150	°C
T_{amb}	ambient temperature	operating in free air	-40	+85	°C

[1] The performance capability of a high-performance integrated circuit in conjunction with its thermal environment can create junction temperatures which are detrimental to reliability. The maximum junction temperature of this integrated circuit should not exceed 125 °C.

18. Static characteristics

Table 19. Static characteristics

$V_{DD} = 2.3\text{ V to }3.6\text{ V}$; $V_{SS} = 0\text{ V}$; $T_{amb} = -40\text{ °C to }+85\text{ °C}$; unless otherwise specified.

Symbol	Parameter	Conditions	Min	Typ	Max	Unit
Supply						
V_{DD}	supply voltage		2.3	-	3.6	V
I_{DD}	supply current	Operating mode; no load; $V_I = V_{DD}$ or V_{SS} ; $f_{SCL} = 1\text{ MHz}$; RESET – V_{DD} ^[6]				
		$V_{DD} = 2.3\text{ V}$	-	127 ^[4]	210 ^[5]	μA
		$V_{DD} = 3.6\text{ V}$	-	184 ^[2]	325	μA
I_{stb}	standby current	Standby mode; no load; $V_I = V_{DD}$ or V_{SS} ; $f_{SCL} = 0\text{ kHz}$; RESET – V_{DD} ^[6]				
		$V_{DD} = 2.3\text{ V}$	-	110 ^[4]	160 ^[5]	μA
		$V_{DD} = 3.6\text{ V}$	-	148 ^[2]	275	μA
V_{POR}	power-on reset voltage	no load; $V_I = V_{DD}$ or V_{SS}	^[1] -	1.5	2.1	V
Input SCL_MSTn; input/output SDA_MSTn (upstream and downstream channels)						
V_{IL}	LOW-level input voltage		-0.5	-	+0.3 V_{DD}	V
V_{IH}	HIGH-level input voltage		0.7 V_{DD}	-	3.6	V
I_{OL}	LOW-level output current	$V_{OL} = 0.4\text{ V}$	20	38 ^[2]	-	mA
I_L	leakage current	$V_I = V_{DD}$ or V_{SS}	-1	-	+1	μA
C_i	input capacitance	$V_I = V_{SS}$				
		$V_{DD} = 2.3\text{ V to }3.6\text{ V}$ ^[5]	-	6	10	pF
Select inputs A0 to A3^[3]						
I_{LI}	input leakage current	$V_I = V_{DD}$ or V_{SS}	-1	-	+1	μA
C_i	input capacitance	$V_I = V_{SS}$				
		$V_{DD} = 2.3\text{ V to }3.6\text{ V}$ ^[5]	-	4	10	pF
Select inputs INT_IN, RESET						
V_{IL}	LOW-level input voltage		-0.5	-	+0.3 V_{DD}	V
V_{IH}	HIGH-level input voltage		0.7 V_{DD}	-	3.6	V
I_{LI}	input leakage current	$V_I = V_{DD}$ or V_{SS}	-1	-	+1	μA
C_i	input capacitance	$V_I = V_{SS}$				
		$V_{DD} = 2.3\text{ V to }3.6\text{ V}$ ^[5]	-	4	10	pF

Table 19. Static characteristics ...continued

$V_{DD} = 2.3\text{ V to }3.6\text{ V}$; $V_{SS} = 0\text{ V}$; $T_{amb} = -40\text{ }^{\circ}\text{C to }+85\text{ }^{\circ}\text{C}$; unless otherwise specified.

Symbol	Parameter	Conditions	Min	Typ	Max	Unit
Pass gate						
R _{on}	ON-state resistance	$V_O = 0.4\text{ V}$; $I_O = 20\text{ mA}$				
		$V_{DD} = 3.0\text{ V to }3.6\text{ V}$	-	7.9 ^[2]	11.5	Ω
		$V_{DD} = 2.3\text{ V to }2.7\text{ V}$	-	9.9 ^[4]	14.5	Ω
V _{o(sw)}	switch output voltage	$I_{o(sw)} = -100\text{ }μ\text{A}$				
		$V_{i(sw)} = V_{DD} = 3.6\text{ V}$	1.6	2.0 ^[2]	2.8	V
		$V_{i(sw)} = V_{DD} = 2.3\text{ V}$	1.1	1.4 ^[4]	2.2	V
I _L	leakage current	$V_I = V_{DD}\text{ or }V_{SS}$	-1	-	+1	μA
INT0 and INT1 outputs						
I _{OL}	LOW-level output current	$V_{OL} = 0.4\text{ V}$	3	-	-	mA

[1] V_{DD} must be lowered to 0.7 V in order to reset part

[2] Typical $V_{DD} = 3.0\text{ V}$ at room temperature

[3] See [Table 4](#)

[4] Typical $V_{DD} = 2.3\text{ V}$ at room temperature, nominal device

[5] Guaranteed by characterization

[6] When RESET = V_{SS} , I_{DD} and I_{stb} increase approximately 4.5 mA

19. Dynamic characteristics

Table 20. Dynamic characteristics

Symbol	Parameter	Conditions	Standard-mode I ² C-bus		Fast-mode I ² C-bus		Fast-mode Plus I ² C-bus		Unit	
			Min	Max	Min	Max	Min	Max		
t _{PD}	propagation delay	(SDA_MSTn to SDA_SLAVE) or (SCL_MSTn to SCL_SLAVE)	^[1]	-	0.3	-	0.3	-	0.3	ns
f _{SCL}	SCL clock frequency			20	100	20	400	20	1000	kHz
f _{SCL(init/rec)}	SCL clock frequency (bus initialization/ bus recovery)		^[8]	18	50	18	50	18	50	kHz
t _{BUF}	bus free time between a STOP and START condition			4.7	-	1.3	-	0.5	-	μs
t _{HD;STA}	hold time (repeated) START condition		^[2]	4.0	-	0.6	-	0.26	-	μs
t _{LOW}	LOW period of the SCL clock			4.7	-	1.3	-	0.5	-	μs
t _{HIGH}	HIGH period of the SCL clock			4.0	-	0.6	-	0.26	-	μs

Table 20. Dynamic characteristics ...continued

Symbol	Parameter	Conditions	Standard-mode I ² C-bus		Fast-mode I ² C-bus		Fast-mode Plus I ² C-bus		Unit
			Min	Max	Min	Max	Min	Max	
t _{SU;STA}	set-up time for a repeated START condition		4.7	-	0.6	-	0.26	-	μs
t _{SU;STO}	set-up time for STOP condition		4.0	-	0.6	-	0.26	-	μs
t _{HD;DAT}	data hold time		0 ^[3]	3.45	0 ^[3]	0.9	0 ^[3]	-	μs
t _{SU;DAT}	data set-up time		250	-	100	-	50	-	ns
t _r	rise time of both SDA and SCL signals		-	1000	20	300	-	120	ns
t _f	fall time of both SDA and SCL signals		-	300	20 × (V _{DD} / 3.3 V)	300	20 × (V _{DD} / 3.3 V)	120	ns
C _b	capacitive load for each bus line		^[4]	400	-	400	-	500	pF
t _{SP}	pulse width of spikes that must be suppressed by the input filter		-	50	-	50	-	50	ns
t _{VD;DAT}	data valid time		^[5]	1	-	1	0.05	0.45	μs
t _{VD;ACK}	data valid acknowledge time		-	1	-	1	0.05	0.45	μs
INT									
t _{v(INT_IN-INTn)}	valid time from pin INT_IN to pin INTn signal		-	4	-	4	-	4	μs
t _{w(rej)L}	LOW-level rejection time	INT_IN input	0.05	-	0.05	-	0.05	-	μs
RESET									
t _{w(rst)L}	LOW-level reset time		10	-	10	-	10	-	ns
t _{rst}	reset time	SDA clear	500	-	500	-	500	-	ns
t _{REC;STA}	recovery time to START condition		^{[6][7]}	90	-	90	-	90	μs

[1] Pass gate propagation delay is calculated from the 20 Ω typical R_{on} and the 15 pF load capacitance.

[2] After this period, the first clock pulse is generated.

[3] A device must internally provide a hold time of at least 300 ns for the SDA signal (referred to the V_{IH(min)} of the SCL signal) in order to bridge the undefined region of the falling edge of SCL.

[4] C_b = total capacitance of one bus line in pF.

[5] Measurements taken with 1 kΩ pull-up resistor and 50 pF load.

[6] Resetting the device while actively communicating on the bus may cause glitches or errant STOP conditions.

[7] Upon reset, the full delay will be the sum of t_{rst} and the RC time constant of the SDA bus.

[8] Guaranteed by characterization.

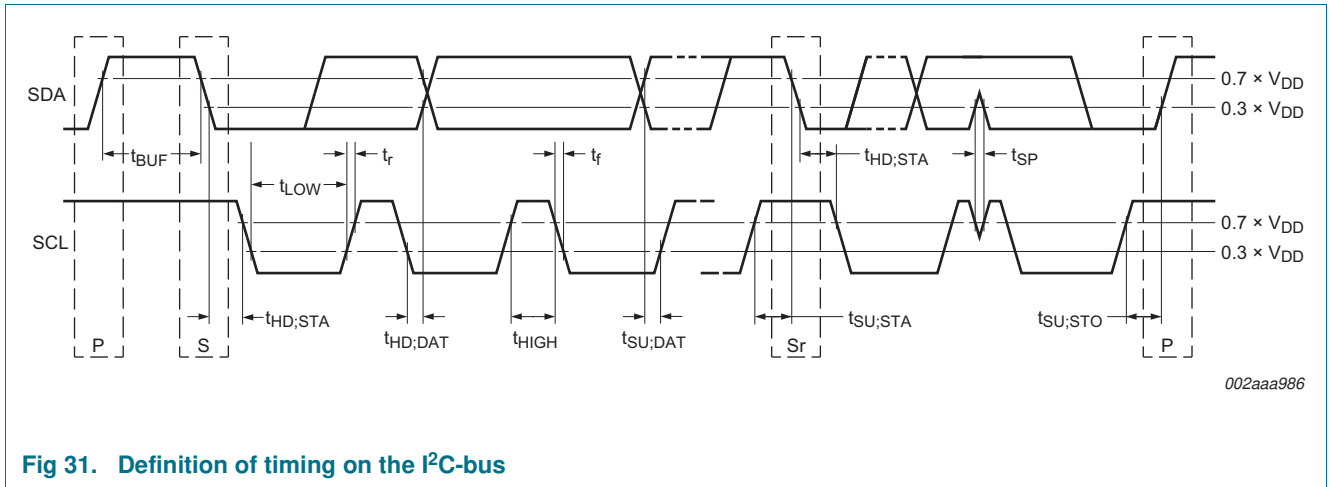

Fig 31. Definition of timing on the I²C-bus

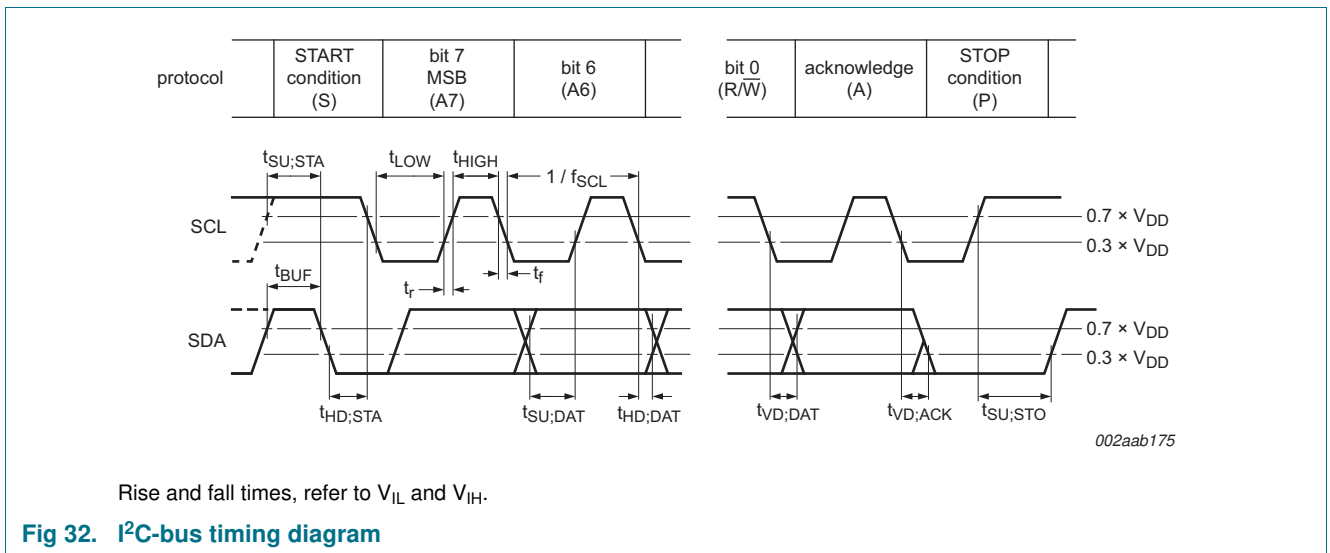

Fig 32. I²C-bus timing diagram

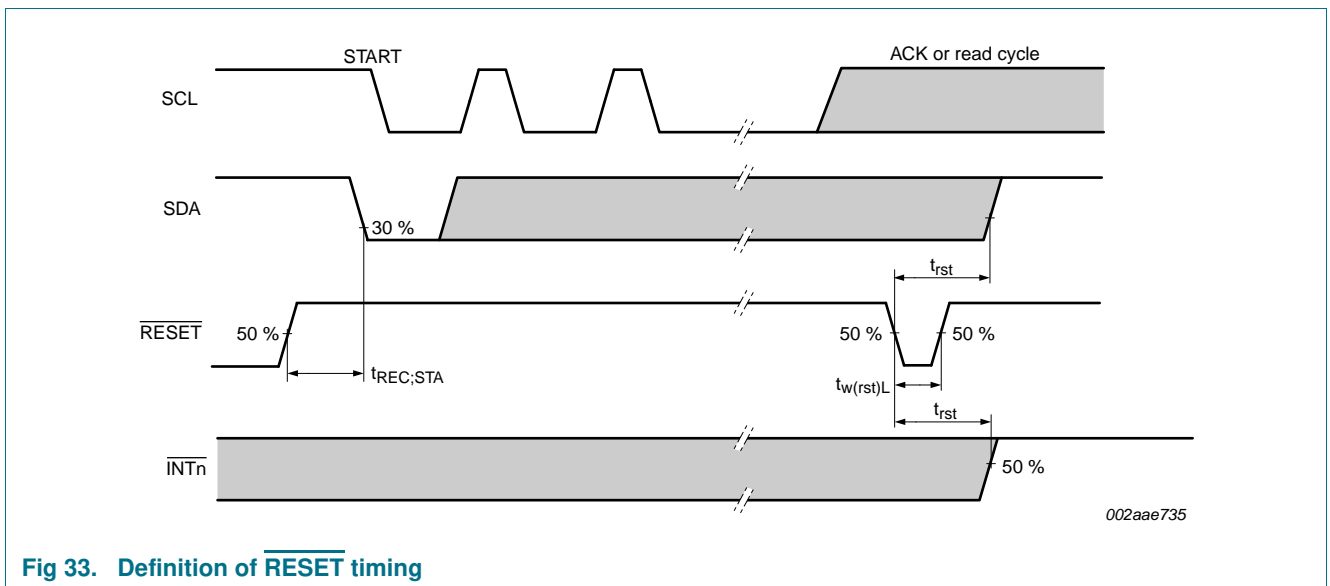
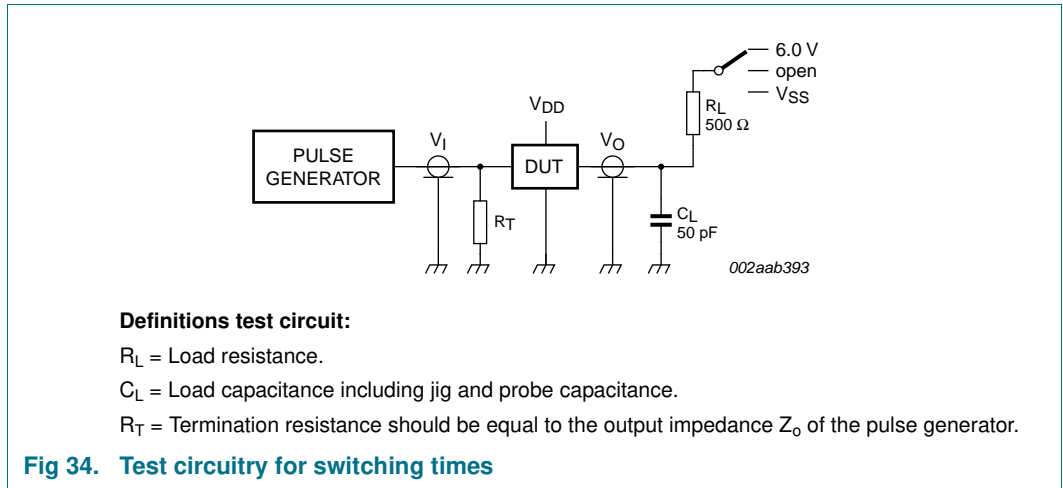

Fig 33. Definition of RESET timing

20. Test information



21. Package outline

TSSOP16: plastic thin shrink small outline package; 16 leads; body width 4.4 mm

SOT403-1

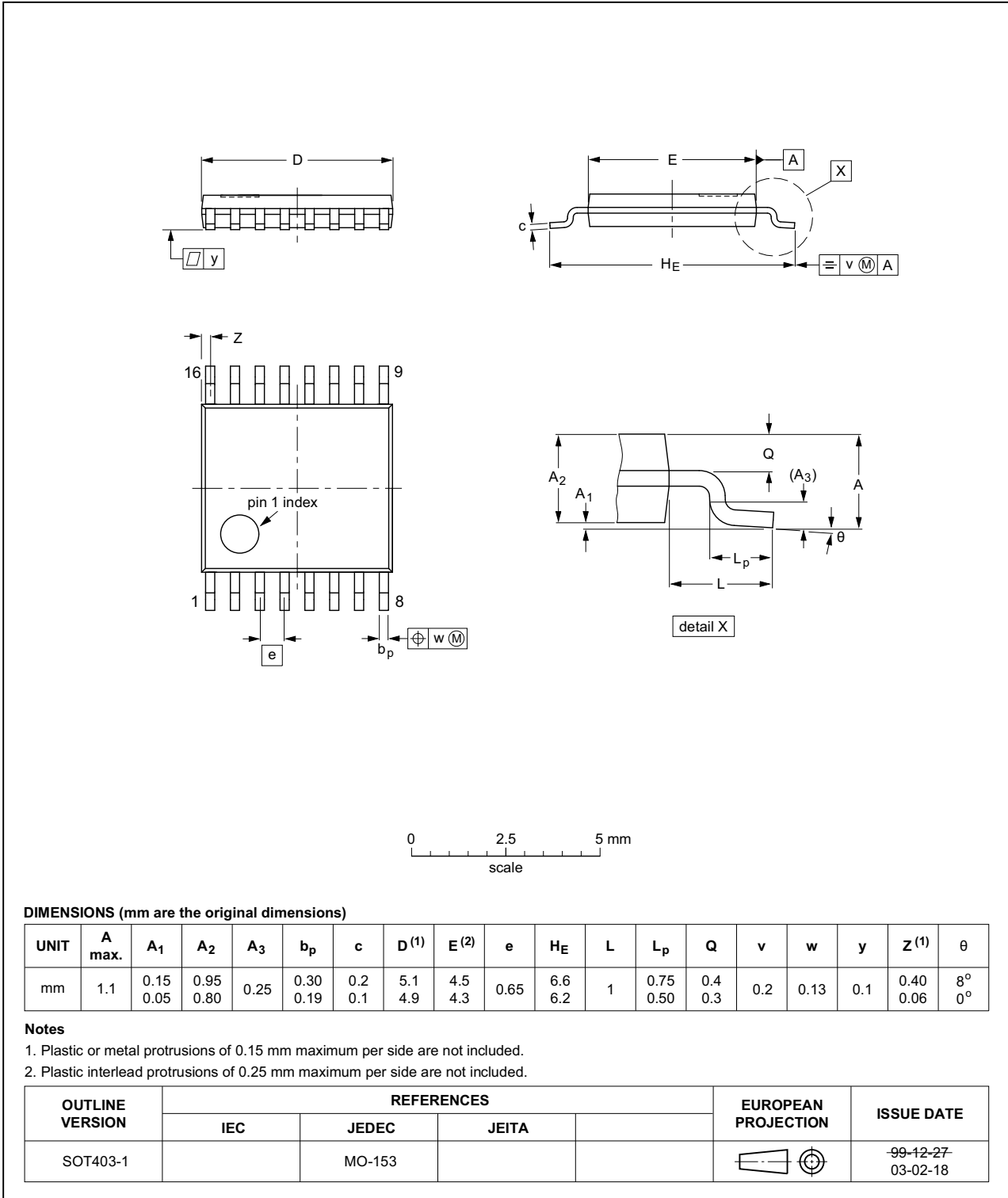

Fig 35. Package outline SOT403-1 (TSSOP16)

HVQFN16: plastic thermal enhanced very thin quad flat package; no leads;
16 terminals; body 3 x 3 x 0.85 mm

SOT758-1

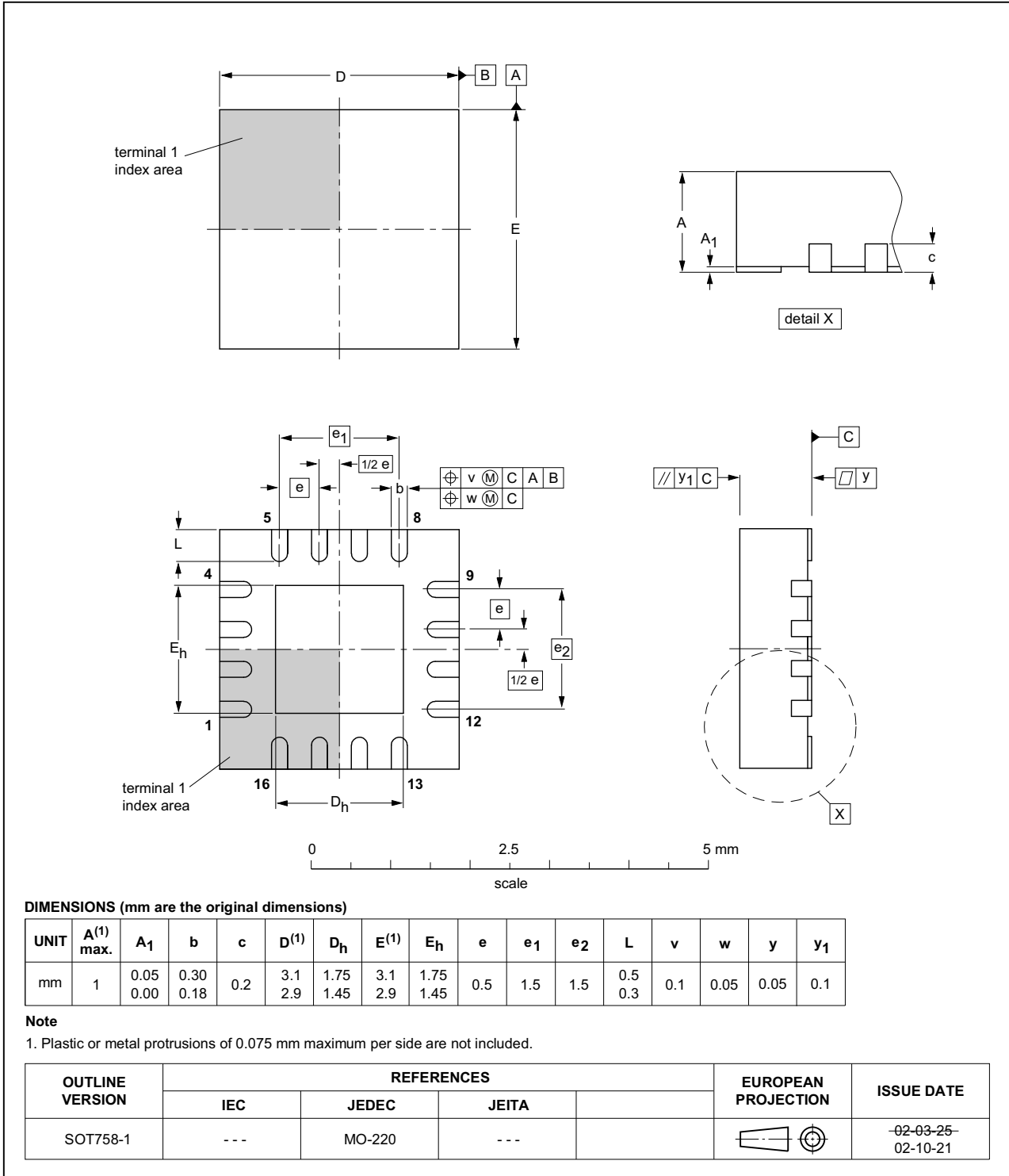

Fig 36. Package outline SOT758-1 (HVQFN16)

22. Soldering of SMD packages

This text provides a very brief insight into a complex technology. A more in-depth account of soldering ICs can be found in Application Note *AN10365 "Surface mount reflow soldering description"*.

22.1 Introduction to soldering

Soldering is one of the most common methods through which packages are attached to Printed Circuit Boards (PCBs), to form electrical circuits. The soldered joint provides both the mechanical and the electrical connection. There is no single soldering method that is ideal for all IC packages. Wave soldering is often preferred when through-hole and Surface Mount Devices (SMDs) are mixed on one printed wiring board; however, it is not suitable for fine pitch SMDs. Reflow soldering is ideal for the small pitches and high densities that come with increased miniaturization.

22.2 Wave and reflow soldering

Wave soldering is a joining technology in which the joints are made by solder coming from a standing wave of liquid solder. The wave soldering process is suitable for the following:

- Through-hole components
- Leaded or leadless SMDs, which are glued to the surface of the printed circuit board

Not all SMDs can be wave soldered. Packages with solder balls, and some leadless packages which have solder lands underneath the body, cannot be wave soldered. Also, leaded SMDs with leads having a pitch smaller than ~0.6 mm cannot be wave soldered, due to an increased probability of bridging.

The reflow soldering process involves applying solder paste to a board, followed by component placement and exposure to a temperature profile. Leaded packages, packages with solder balls, and leadless packages are all reflow solderable.

Key characteristics in both wave and reflow soldering are:

- Board specifications, including the board finish, solder masks and vias
- Package footprints, including solder thieves and orientation
- The moisture sensitivity level of the packages
- Package placement
- Inspection and repair
- Lead-free soldering versus SnPb soldering

22.3 Wave soldering

Key characteristics in wave soldering are:

- Process issues, such as application of adhesive and flux, clinching of leads, board transport, the solder wave parameters, and the time during which components are exposed to the wave
- Solder bath specifications, including temperature and impurities

22.4 Reflow soldering

Key characteristics in reflow soldering are:

- Lead-free versus SnPb soldering; note that a lead-free reflow process usually leads to higher minimum peak temperatures (see [Figure 37](#)) than a SnPb process, thus reducing the process window
- Solder paste printing issues including smearing, release, and adjusting the process window for a mix of large and small components on one board
- Reflow temperature profile; this profile includes preheat, reflow (in which the board is heated to the peak temperature) and cooling down. It is imperative that the peak temperature is high enough for the solder to make reliable solder joints (a solder paste characteristic). In addition, the peak temperature must be low enough that the packages and/or boards are not damaged. The peak temperature of the package depends on package thickness and volume and is classified in accordance with [Table 21](#) and [22](#)

Table 21. SnPb eutectic process (from J-STD-020D)

Package thickness (mm)	Package reflow temperature (°C)	
	Volume (mm ³)	
	< 350	≥ 350
< 2.5	235	220
≥ 2.5	220	220

Table 22. Lead-free process (from J-STD-020D)

Package thickness (mm)	Package reflow temperature (°C)		
	Volume (mm ³)		
	< 350	350 to 2000	> 2000
< 1.6	260	260	260
1.6 to 2.5	260	250	245
> 2.5	250	245	245

Moisture sensitivity precautions, as indicated on the packing, must be respected at all times.

Studies have shown that small packages reach higher temperatures during reflow soldering, see [Figure 37](#).

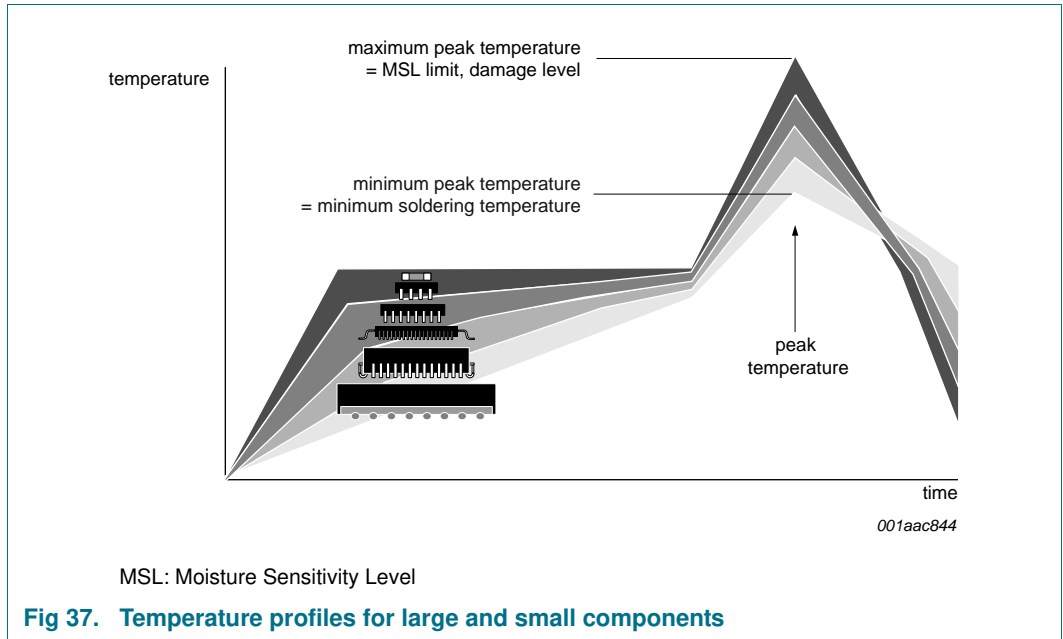

For further information on temperature profiles, refer to Application Note AN10365 “Surface mount reflow soldering description”.

Footprint information for reflow soldering of HVQFN16 package

SOT758-1

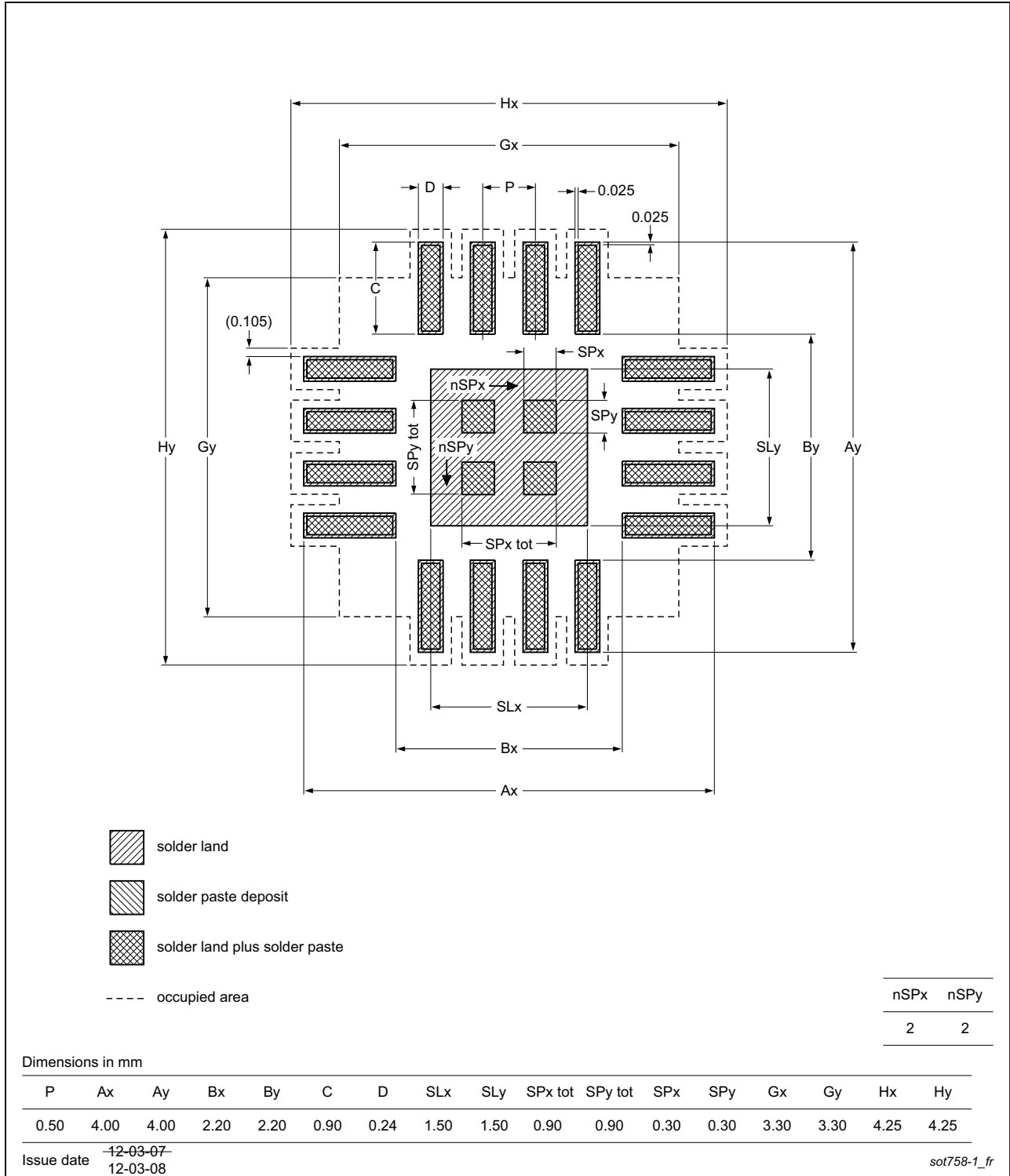

Fig 39. PCB footprint for SOT758-1 (HVQFN16); reflow soldering

24. Abbreviations

Table 23. Abbreviations

Acronym	Description
AI	Auto Increment
CDM	Charged Device Model
DUT	Device Under Test
EEPROM	Electrically Erasable Programmable Read-Only Memory
ESD	ElectroStatic Discharge
FRU	Field Replaceable Unit
HBM	Human Body Model
I ² C-bus	Inter Integrated Circuit bus
IC	Integrated Circuit
POR	Power-On Reset
RC	Resistor-Capacitor network
SMBus	System Management Bus

25. Revision history

Table 24. Revision history

Document ID	Release date	Data sheet status	Change notice	Supersedes
PCA9641 v.2.1	20151027	Product data sheet	-	PCA90641 v.2
Modifications:		<ul style="list-style-type: none"> Table 20: Corrected $t_{REC;STA}$ from 155 ms to 90 us 		
PCA9641 v.2	20141010	Product data sheet	-	PCA90641 v.1
<ul style="list-style-type: none"> Modifications: 		<ul style="list-style-type: none"> Corrected Figure 1, Figure 2, Figure 3, Figure 21 and Figure 26 		
PCA9641 v.1	20141008	Product data sheet	-	-

26. Legal information

26.1 Data sheet status

Document status ^{[1][2]}	Product status ^[3]	Definition
Objective [short] data sheet	Development	This document contains data from the objective specification for product development.
Preliminary [short] data sheet	Qualification	This document contains data from the preliminary specification.
Product [short] data sheet	Production	This document contains the product specification.

[1] Please consult the most recently issued document before initiating or completing a design.

[2] The term 'short data sheet' is explained in section "Definitions".

[3] The product status of device(s) described in this document may have changed since this document was published and may differ in case of multiple devices. The latest product status information is available on the Internet at URL <http://www.nxp.com>.

26.2 Definitions

Draft — The document is a draft version only. The content is still under internal review and subject to formal approval, which may result in modifications or additions. NXP Semiconductors does not give any representations or warranties as to the accuracy or completeness of information included herein and shall have no liability for the consequences of use of such information.

Short data sheet — A short data sheet is an extract from a full data sheet with the same product type number(s) and title. A short data sheet is intended for quick reference only and should not be relied upon to contain detailed and full information. For detailed and full information see the relevant full data sheet, which is available on request via the local NXP Semiconductors sales office. In case of any inconsistency or conflict with the short data sheet, the full data sheet shall prevail.

Product specification — The information and data provided in a Product data sheet shall define the specification of the product as agreed between NXP Semiconductors and its customer, unless NXP Semiconductors and customer have explicitly agreed otherwise in writing. In no event however, shall an agreement be valid in which the NXP Semiconductors product is deemed to offer functions and qualities beyond those described in the Product data sheet.

26.3 Disclaimers

Limited warranty and liability — Information in this document is believed to be accurate and reliable. However, NXP Semiconductors does not give any representations or warranties, expressed or implied, as to the accuracy or completeness of such information and shall have no liability for the consequences of use of such information. NXP Semiconductors takes no responsibility for the content in this document if provided by an information source outside of NXP Semiconductors.

In no event shall NXP Semiconductors be liable for any indirect, incidental, punitive, special or consequential damages (including - without limitation - lost profits, lost savings, business interruption, costs related to the removal or replacement of any products or rework charges) whether or not such damages are based on tort (including negligence), warranty, breach of contract or any other legal theory.

Notwithstanding any damages that customer might incur for any reason whatsoever, NXP Semiconductors' aggregate and cumulative liability towards customer for the products described herein shall be limited in accordance with the *Terms and conditions of commercial sale* of NXP Semiconductors.

Right to make changes — NXP Semiconductors reserves the right to make changes to information published in this document, including without limitation specifications and product descriptions, at any time and without notice. This document supersedes and replaces all information supplied prior to the publication hereof.

Suitability for use — NXP Semiconductors products are not designed, authorized or warranted to be suitable for use in life support, life-critical or safety-critical systems or equipment, nor in applications where failure or malfunction of an NXP Semiconductors product can reasonably be expected to result in personal injury, death or severe property or environmental damage. NXP Semiconductors and its suppliers accept no liability for inclusion and/or use of NXP Semiconductors products in such equipment or applications and therefore such inclusion and/or use is at the customer's own risk.

Applications — Applications that are described herein for any of these products are for illustrative purposes only. NXP Semiconductors makes no representation or warranty that such applications will be suitable for the specified use without further testing or modification.

Customers are responsible for the design and operation of their applications and products using NXP Semiconductors products, and NXP Semiconductors accepts no liability for any assistance with applications or customer product design. It is customer's sole responsibility to determine whether the NXP Semiconductors product is suitable and fit for the customer's applications and products planned, as well as for the planned application and use of customer's third party customer(s). Customers should provide appropriate design and operating safeguards to minimize the risks associated with their applications and products.

NXP Semiconductors does not accept any liability related to any default, damage, costs or problem which is based on any weakness or default in the customer's applications or products, or the application or use by customer's third party customer(s). Customer is responsible for doing all necessary testing for the customer's applications and products using NXP Semiconductors products in order to avoid a default of the applications and the products or of the application or use by customer's third party customer(s). NXP does not accept any liability in this respect.

Limiting values — Stress above one or more limiting values (as defined in the Absolute Maximum Ratings System of IEC 60134) will cause permanent damage to the device. Limiting values are stress ratings only and (proper) operation of the device at these or any other conditions above those given in the Recommended operating conditions section (if present) or the Characteristics sections of this document is not warranted. Constant or repeated exposure to limiting values will permanently and irreversibly affect the quality and reliability of the device.

Terms and conditions of commercial sale — NXP Semiconductors products are sold subject to the general terms and conditions of commercial sale, as published at <http://www.nxp.com/profile/terms>, unless otherwise agreed in a valid written individual agreement. In case an individual agreement is concluded only the terms and conditions of the respective agreement shall apply. NXP Semiconductors hereby expressly objects to applying the customer's general terms and conditions with regard to the purchase of NXP Semiconductors products by customer.

No offer to sell or license — Nothing in this document may be interpreted or construed as an offer to sell products that is open for acceptance or the grant, conveyance or implication of any license under any copyrights, patents or other industrial or intellectual property rights.

Export control — This document as well as the item(s) described herein may be subject to export control regulations. Export might require a prior authorization from competent authorities.

Non-automotive qualified products — Unless this data sheet expressly states that this specific NXP Semiconductors product is automotive qualified, the product is not suitable for automotive use. It is neither qualified nor tested in accordance with automotive testing or application requirements. NXP Semiconductors accepts no liability for inclusion and/or use of non-automotive qualified products in automotive equipment or applications.

In the event that customer uses the product for design-in and use in automotive applications to automotive specifications and standards, customer (a) shall use the product without NXP Semiconductors' warranty of the product for such automotive applications, use and specifications, and (b) whenever customer uses the product for automotive applications beyond NXP Semiconductors' specifications such use shall be solely at customer's

own risk, and (c) customer fully indemnifies NXP Semiconductors for any liability, damages or failed product claims resulting from customer design and use of the product for automotive applications beyond NXP Semiconductors' standard warranty and NXP Semiconductors' product specifications.

Translations — A non-English (translated) version of a document is for reference only. The English version shall prevail in case of any discrepancy between the translated and English versions.

26.4 Trademarks

Notice: All referenced brands, product names, service names and trademarks are the property of their respective owners.

I²C-bus — logo is a trademark of NXP Semiconductors N.V.

27. Contact information

For more information, please visit: <http://www.nxp.com>

For sales office addresses, please send an email to: salesaddresses@nxp.com

28. Contents

1	General description	1	13	General call software reset	30
2	Features and benefits	2	14	Device ID (PCA9641 ID field)	31
3	Applications	2	15	Shared mailbox	32
4	Ordering information	3	16	Application design-in information	33
4.1	Ordering options	3	16.1	Specific applications	34
5	Block diagram	4	16.2	High reliability systems	34
6	Pinning information	5	16.3	Masters with shared resources	35
6.1	Pinning	5	16.4	Gatekeeper multiplexer	36
6.2	Pin description	5	16.5	Bus initialization/recovery to initialize slaves without hardware reset	37
7	Functional description	6	16.6	Power-on reset requirements	37
7.1	Device address	6	17	Limiting values	39
7.2	Address maps	7	18	Static characteristics	40
7.3	Command Code	10	19	Dynamic characteristics	41
7.4	Power-on reset	11	20	Test information	44
7.5	Reset input ($\overline{\text{RESET}}$)	11	21	Package outline	45
7.6	Software reset	11	22	Soldering of SMD packages	47
7.7	Voltage translation	12	22.1	Introduction to soldering	47
8	Register descriptions	13	22.2	Wave and reflow soldering	47
8.1	Register 0: ID register ([B2:B0] = 000b)	13	22.3	Wave soldering	47
8.2	Register 1: Control register ([B2:B0] = 001b)	13	22.4	Reflow soldering	48
8.3	Register 2: Status register ([B2:B0] = 010b)	16	23	Soldering: PCB footprints	50
8.4	Register 3: Reserve Time register ([B2:B0] = 011b)	18	24	Abbreviations	52
8.5	Register 4: Interrupt Status register ([B2:B0] = 100b)	20	25	Revision history	52
8.6	Register 5: Interrupt Mask register ([B2:B0] = 101b)	21	26	Legal information	53
8.7	Registers 6 and 7: MB registers ([B2:B0] = 110b and 111b)	21	26.1	Data sheet status	53
8.8	Operating cycle of the downstream bus	22	26.2	Definitions	53
8.8.1	Request the downstream bus	22	26.3	Disclaimers	53
8.8.2	Acquire the downstream bus	22	26.4	Trademarks	54
8.8.3	Give up the downstream bus	22	27	Contact information	54
9	Arbitration	23	28	Contents	55
9.1	Rules	23			
9.2	Disconnect events	23			
10	State machines	24			
11	Request grant examples	25			
12	Characteristics of the I²C-bus	25			
12.1	Bit transfer	26			
12.2	START and STOP conditions	26			
12.3	System configuration	26			
12.4	Acknowledge	27			
12.5	Bus transactions	28			
12.6	Auto-increment	29			

Please be aware that important notices concerning this document and the product(s) described herein, have been included in section 'Legal information'.

© NXP Semiconductors N.V. 2015.

All rights reserved.

For more information, please visit: <http://www.nxp.com>

For sales office addresses, please send an email to: salesaddresses@nxp.com

Date of release: 27 October 2015

Document identifier: PCA9641