



TAOGLAS®



Datasheet

CGGBP.25.4.A.02

Part No:
CGGBP.25.4.A.02

Description:

Embedded 25mm GPS/GLONASS/Galileo/BeiDou Patch Antenna,
1561/1575/1602MHz

Features:

- 25*25*4mm Ceramic patch
- High Gain (up to 3.5dBi)
- Excellent stability on the three GNSS systems
- Optimized radiation patterns
- Pin Mount
- RoHS and REACH Compliant

1.	Introduction	3
2.	Specifications	4
3.	Antenna Characteristics	6
4.	Radiation Patterns	9
5.	Mechanical Drawing	11
6.	Antenna Integration Guide	13
7.	Footprint	18
7.	Packaging	19
<hr/>		
	Changelog	20

Taoglas makes no warranties based on the accuracy or completeness of the contents of this document and reserves the right to make changes to specifications and product descriptions at any time without notice. Taoglas reserves all rights to this document and the information contained herein. Reproduction, use or disclosure to third parties without express permission is strictly prohibited.



1. Introduction



This 25mm square embedded ceramic GPS/GLONASS/Galileo/BeiDou patch antenna's wide band of operation leads to excellent gain and radiation pattern stability on all four common commercial GNSS systems worldwide.

Compared to using a smaller antenna, this will translate into the GNSS system having much higher location accuracy, improved reliability of lock in urban areas, better signal reception, with more satellites acquired and a quicker time to first fix.

The patch is mounted via pin and double-sided adhesive. This patch can be tuned subject to NRE and MOQ, for further information please contact your regional Taoglas customer support team.

2. Specifications

GNSS Frequency Bands Covered							
GPS/QZSS	L1 1575.42MHz	L2 1227.6MHz	L5 1176.45MHz	L6 1278.75MHz			
	■	□	□	□			
GLONASS	L5R 1176.45MHz	L3PT 1201.5MHz	L2PT 1246MHz	L1CR 1575.42MHz	L1PT 1602MHz		
	□	□	□	■	■		
Galileo	E5a 1176.45MHz	E5b 1201.5MHz	E4 1215MHz	E3 1256MHz	E6 1278.75MHz	E2 1561MHz	E1 1575.42MHz
	□	□	□	□	□	■	■
BeiDou	B1 1561MHz	B2 1207.14MHz	B3 1268.52MHz				
	■	□	□				
Compass	E5B(B2)/ E6(B3) 1268.56MHz	E2(B1) 1561MHz					
	□	■					
SBAS	Omnistar 1542.5MHz	WAAS/EGN OS 1575.42MHz					
	□	■					

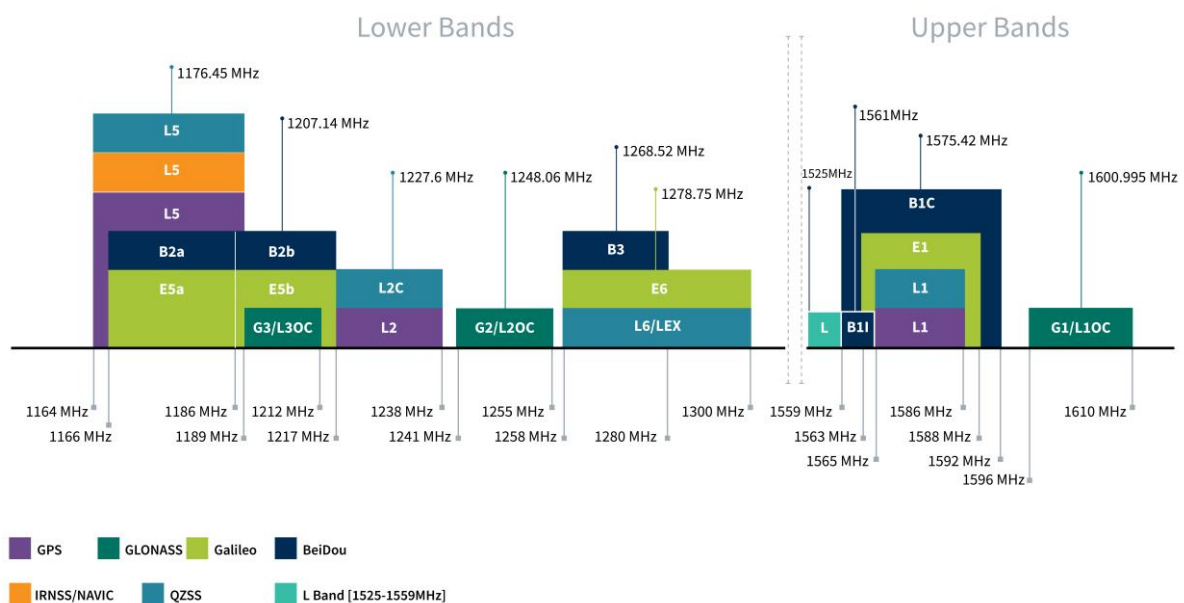

GNSS Bands and Constellations

GNSS Electrical			
Frequency (MHz)	1561	1575	1602
VSWR (max.)	2.5	2.2	2.1
Efficiency (%)	82.15	85.45	79.76
Peak Gain	4.96	4.99	5.48
Average Gain	-0.85	-0.68	-0.38
Centre Frequency			
Impedance			

Mechanical	
Height	4 mm
Planner Dimension	25 x 25 mm
Casing	Ceramic
Pin Diameter	0.9 mm
Pin Length	2.4 mm
Environmental	
Operation Temperature	-40°C to 85°C
Storage Temperature	-40°C to 85°C
Humidity	Non-condensing 65°C 95% RH

3. Antenna Characteristics

3.1 Return Loss

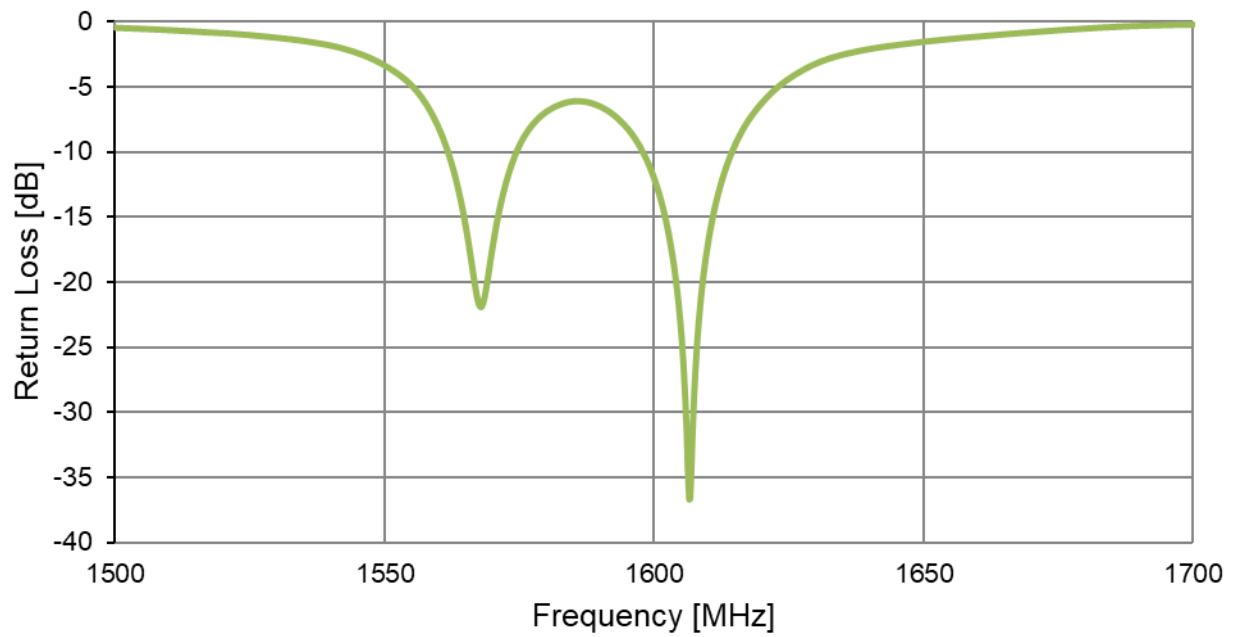

3.2 VSWR

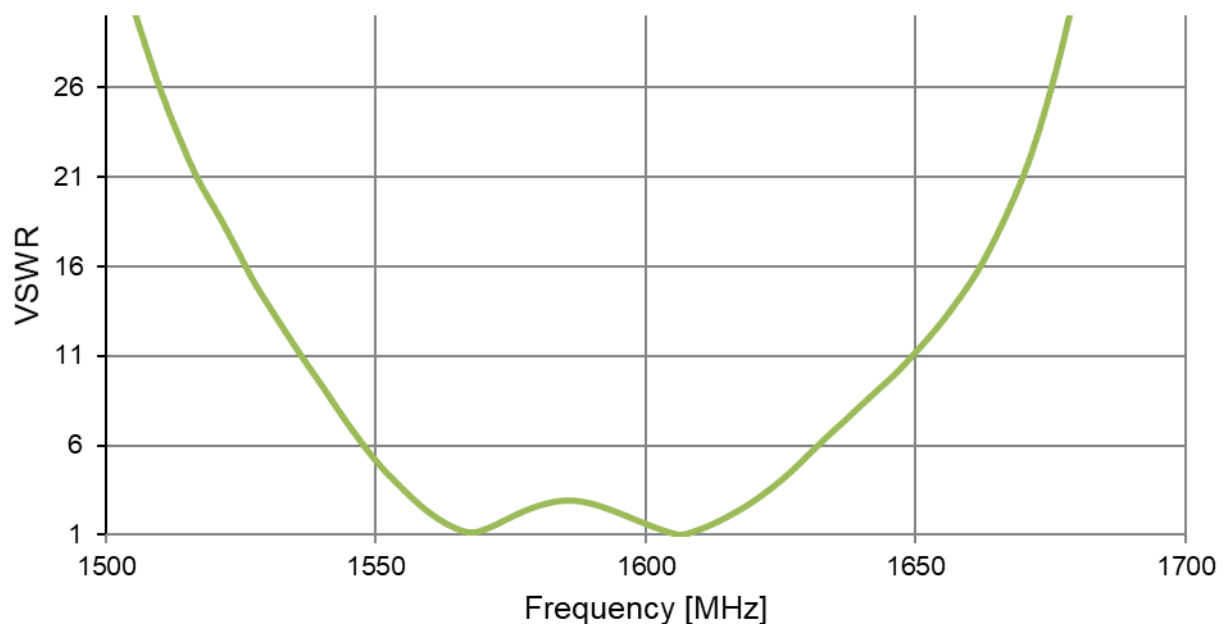

3.3 Efficiency

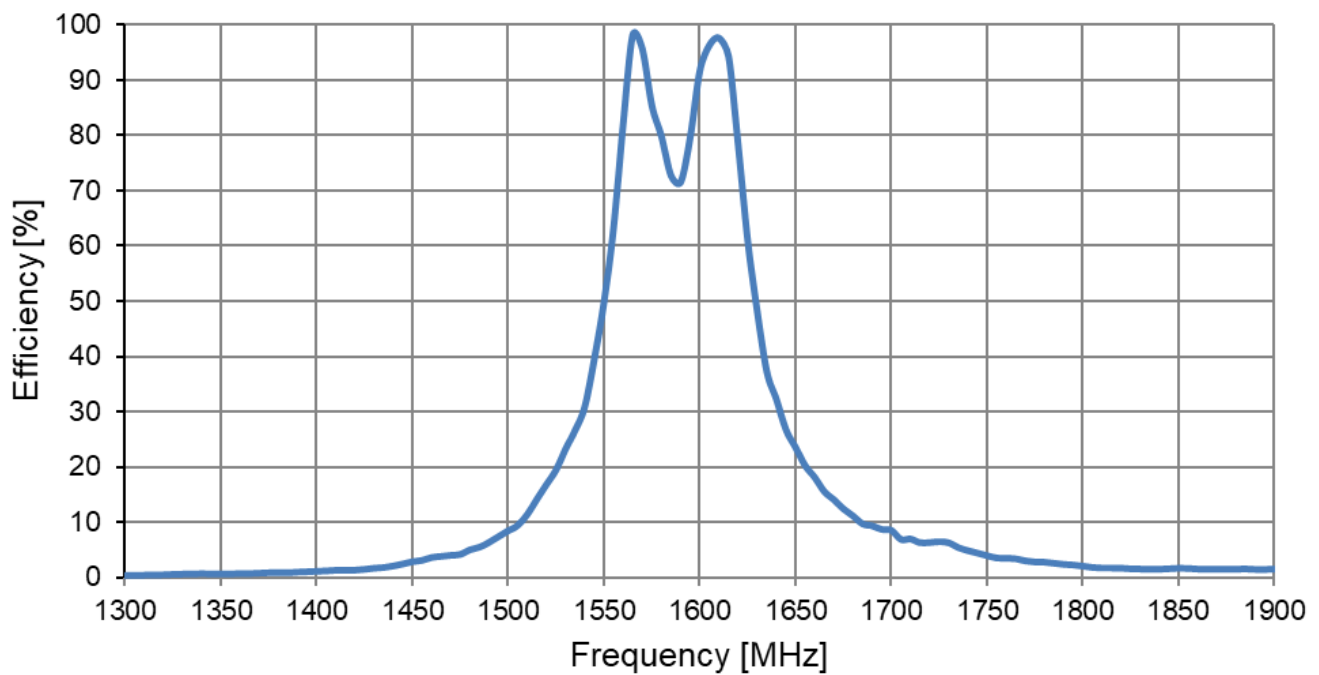

3.4 Peak Gain

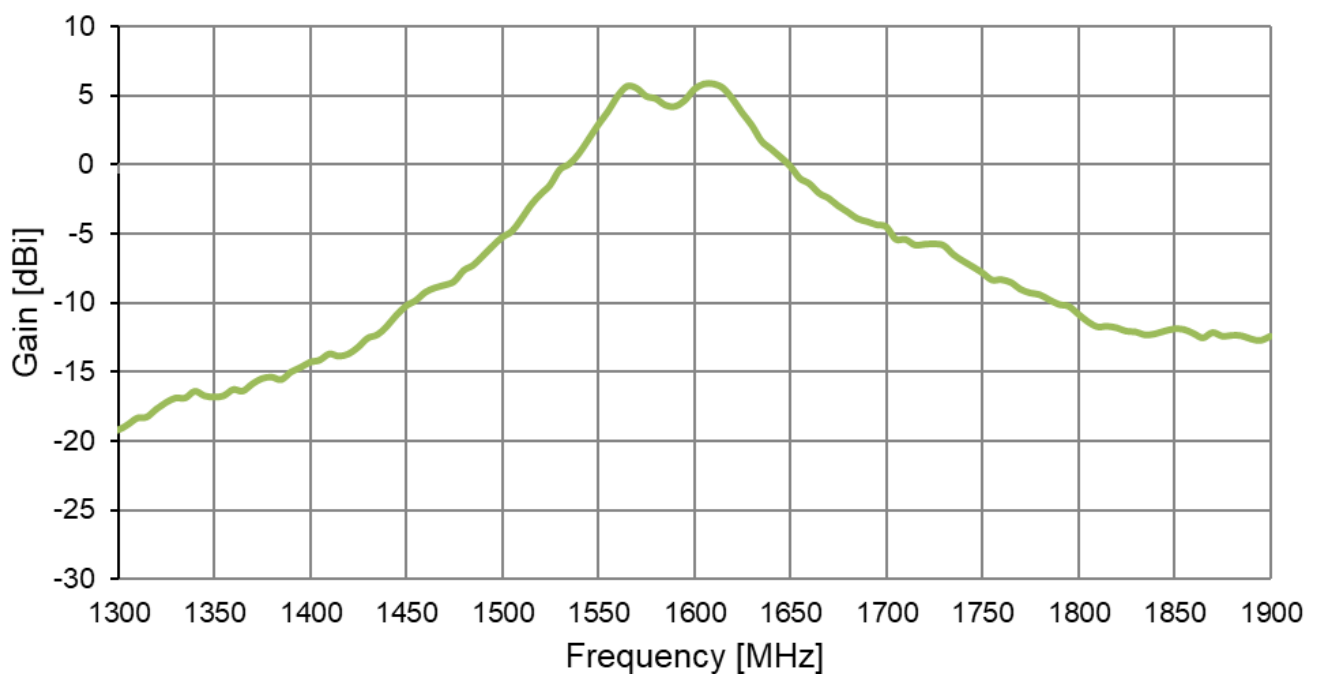

3.5 Average Gain

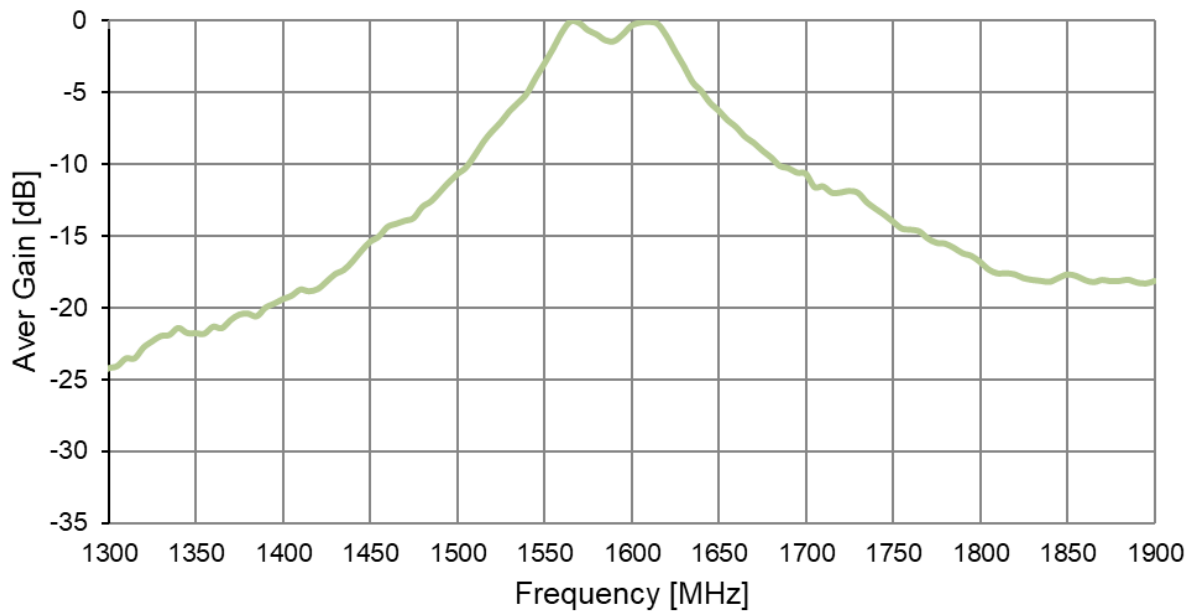

3.6 Axial Ratio

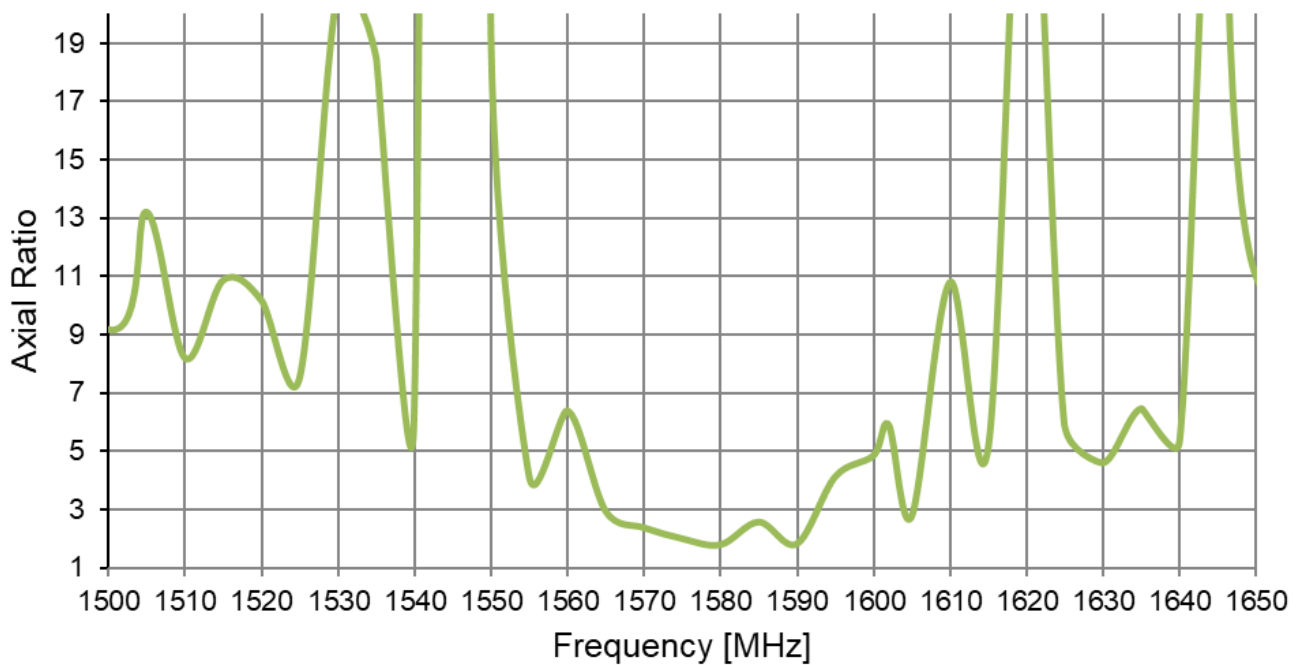

4. Radiation Patterns

4.1 Test Setup

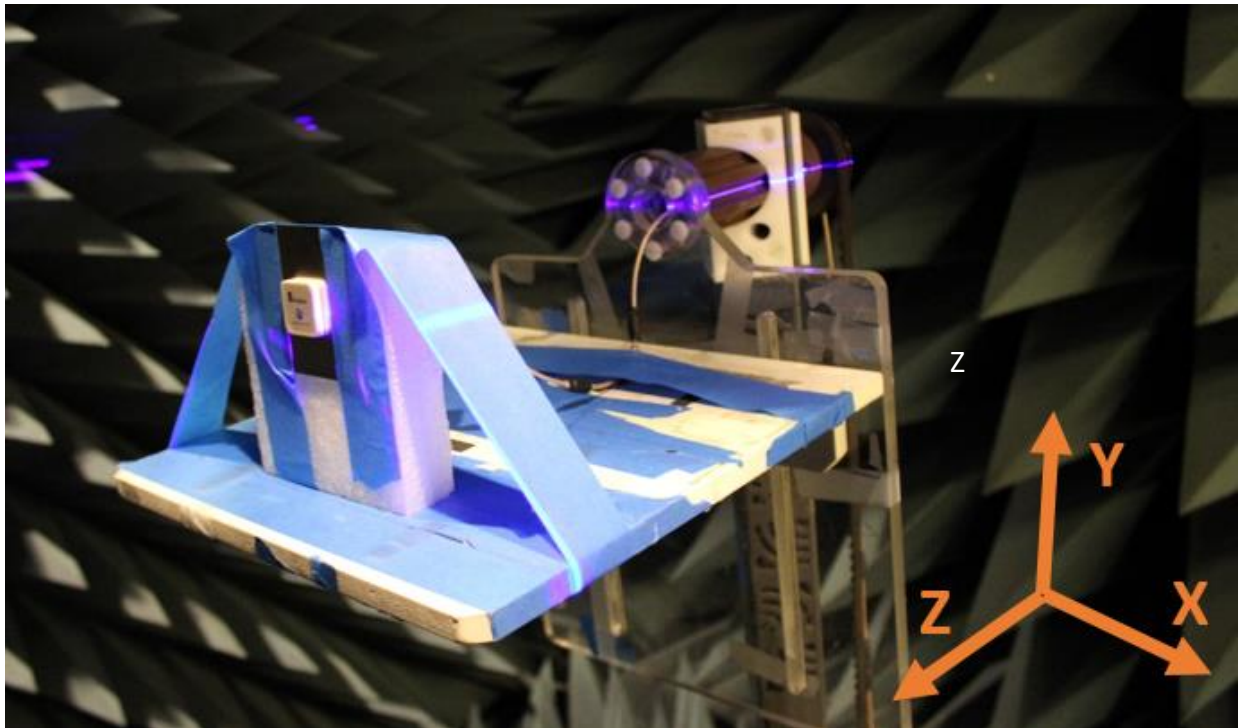

4.2 842MHz 3D and 2D Radiation Patterns

XY Plane

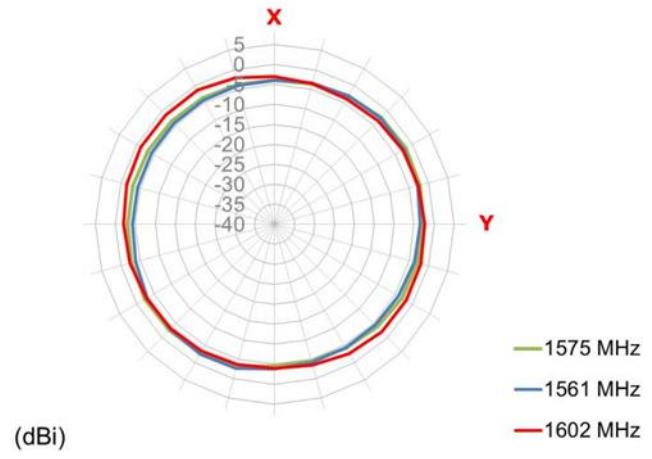

XZ Plane

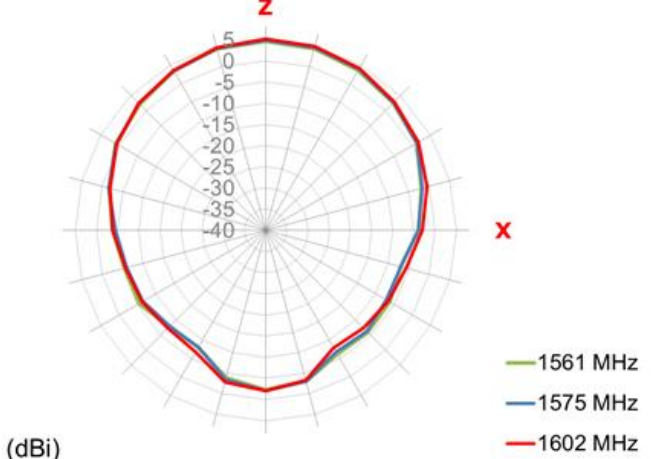

YZ Plane

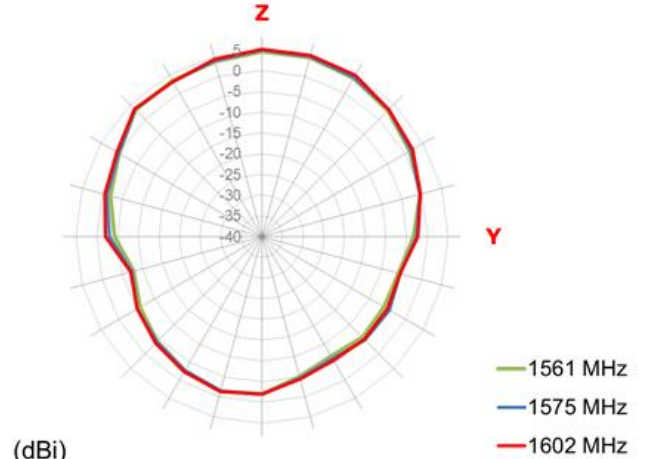

5. Mechanical Drawing (Units: mm)

5.1 Patch Drawings

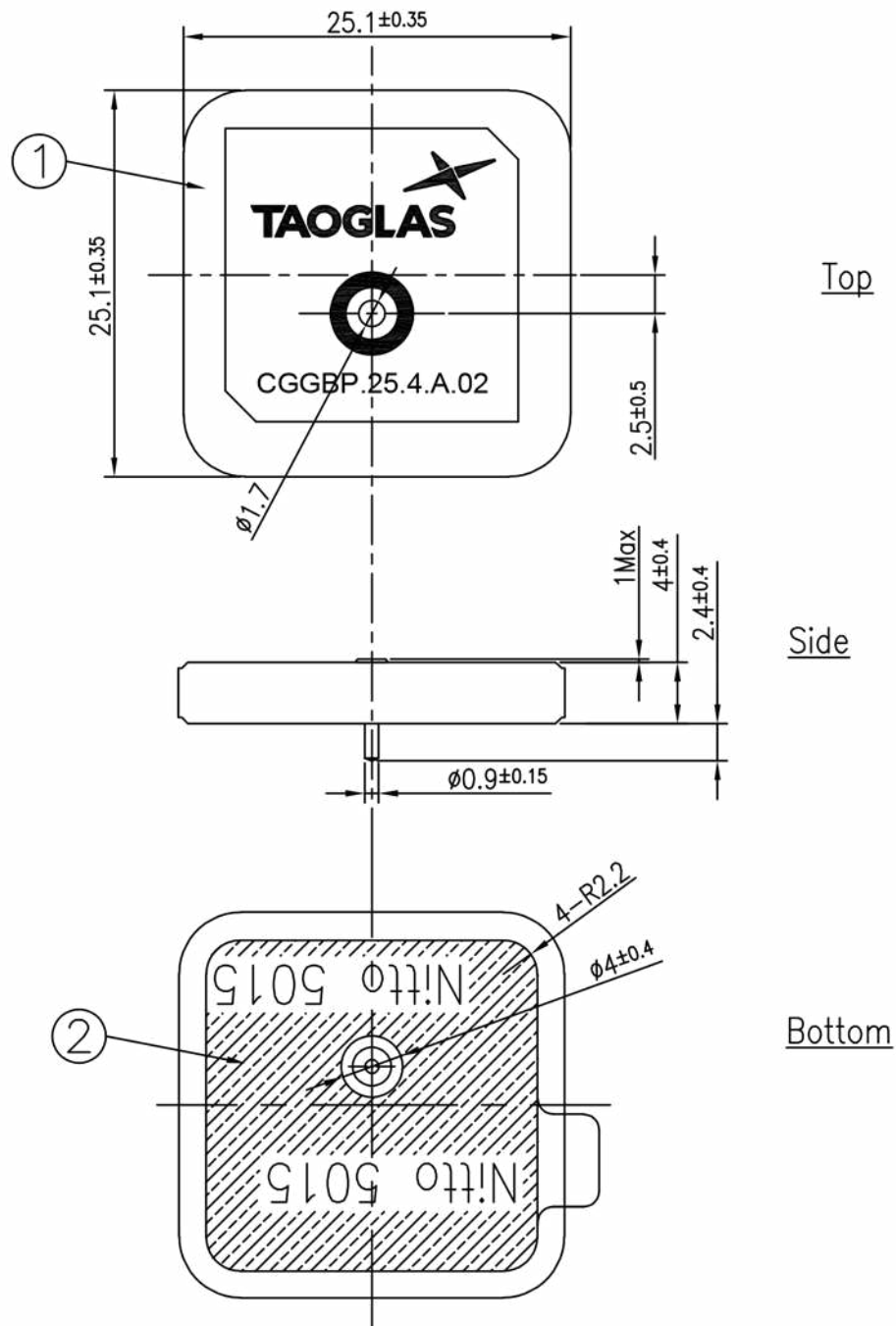

NOTES: 1. Double sided adhesive area. 2. Soldermask Area.

	Name	P/N	Material	Finish	QTY
1	Patch 25x25x4	001513E010007A	Ceramic	Clear	1
2	Double sided Adhesive	001513E010007A	NITTO 5015	White Linter	1

5.2 Adhesive Thickness

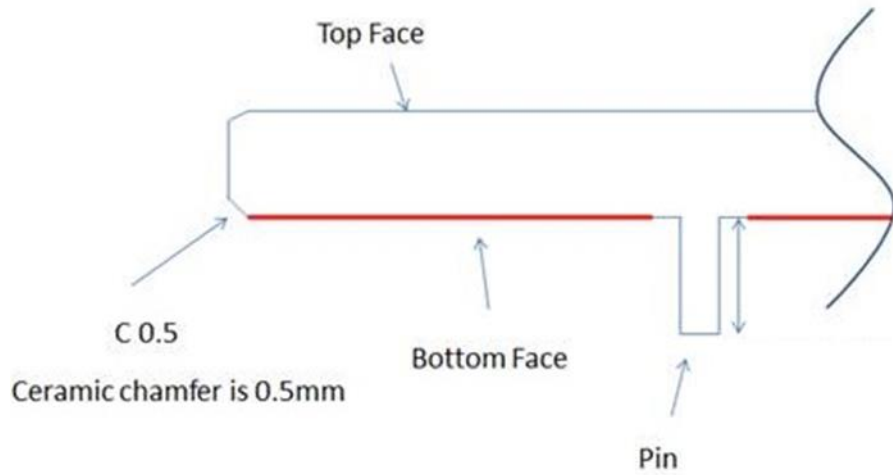

Red line shows the adhesive without Liner – thickness 0.08~0.1 mm

5.2 Groundplane Mechanical Drawing

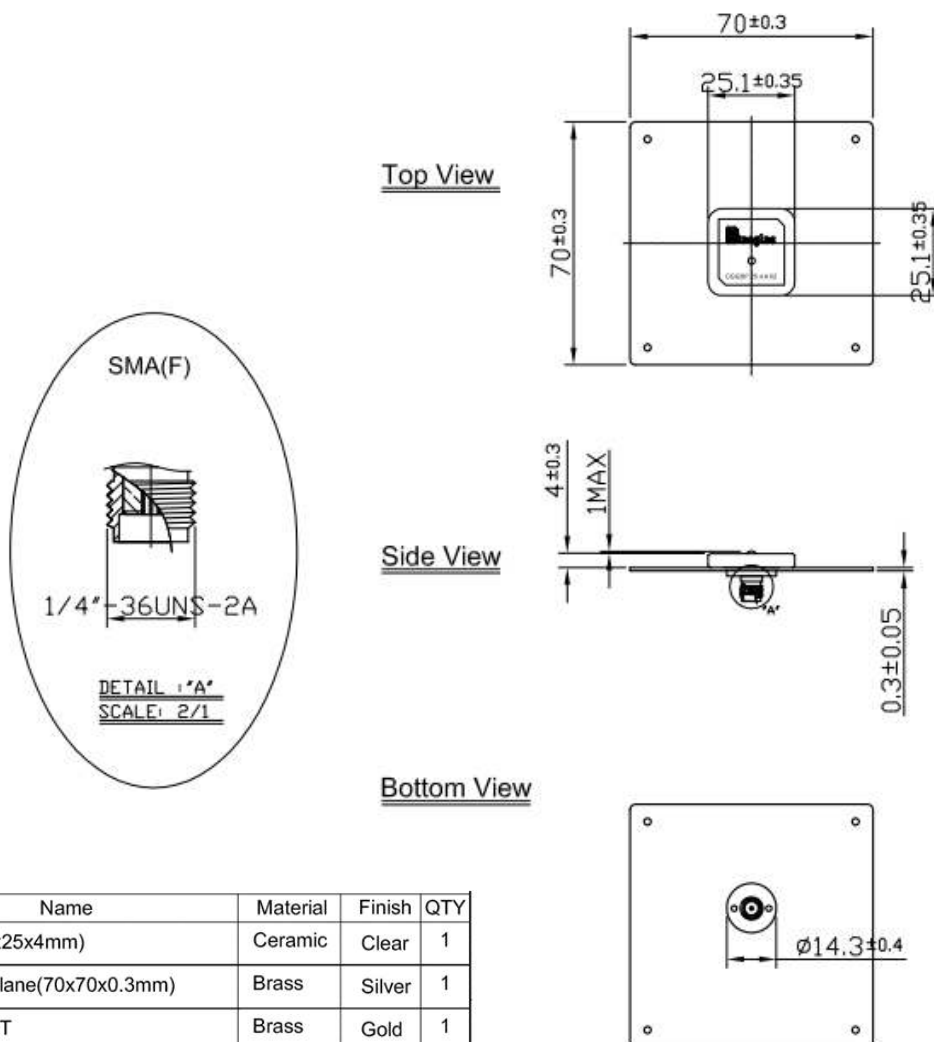

6. Antenna Integration Guide



6.1 Schematic Symbol and Pin Definition

The circuit symbol for the antenna is shown below. The antenna has 1 pin as indicated below.

Pin	Description
1	RF Feed



6.2 Antenna Integration

Whatever the size of the PCB, the antenna should ideally be placed on the PCB's longest side, to take advantage of the ground plane. Optimized matching components can be placed as shown.



Top Side w/ Solder Mask



Top Side w/o Solder Mask

6.3 PCB Layout

The footprint and clearance on the PCB must comply with the antenna specification. The PCB layout shown in the diagram below demonstrates the antenna footprint.



Topside

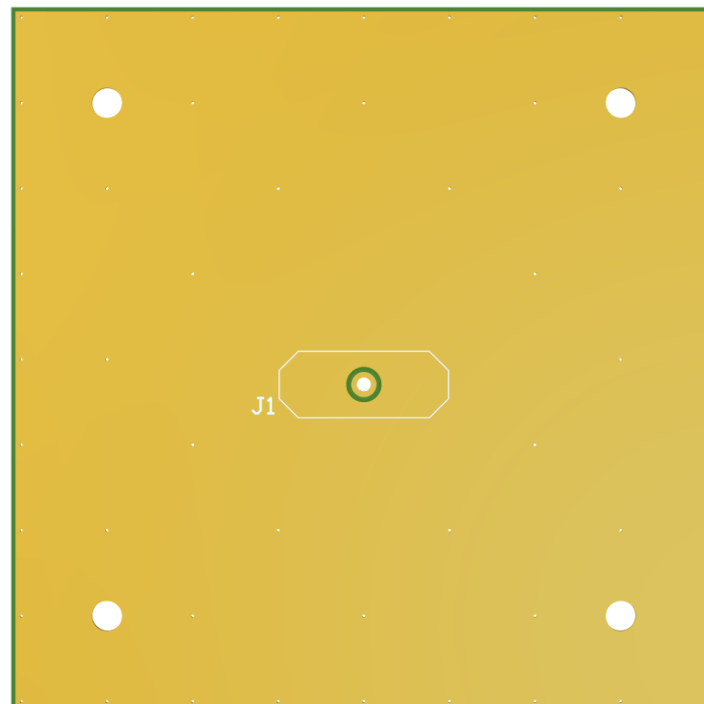

Bottom Side

6.5 Evaluation Board

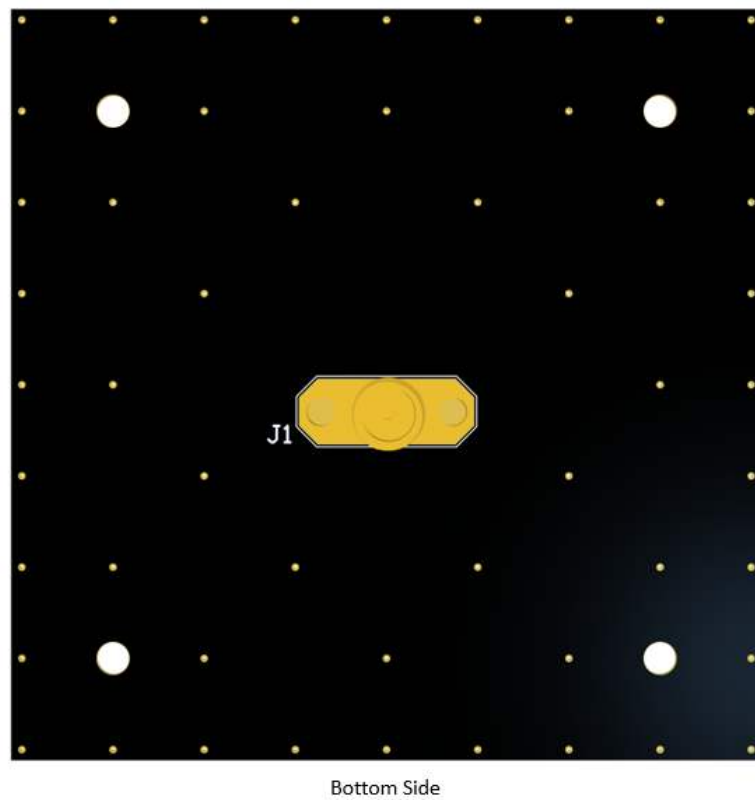
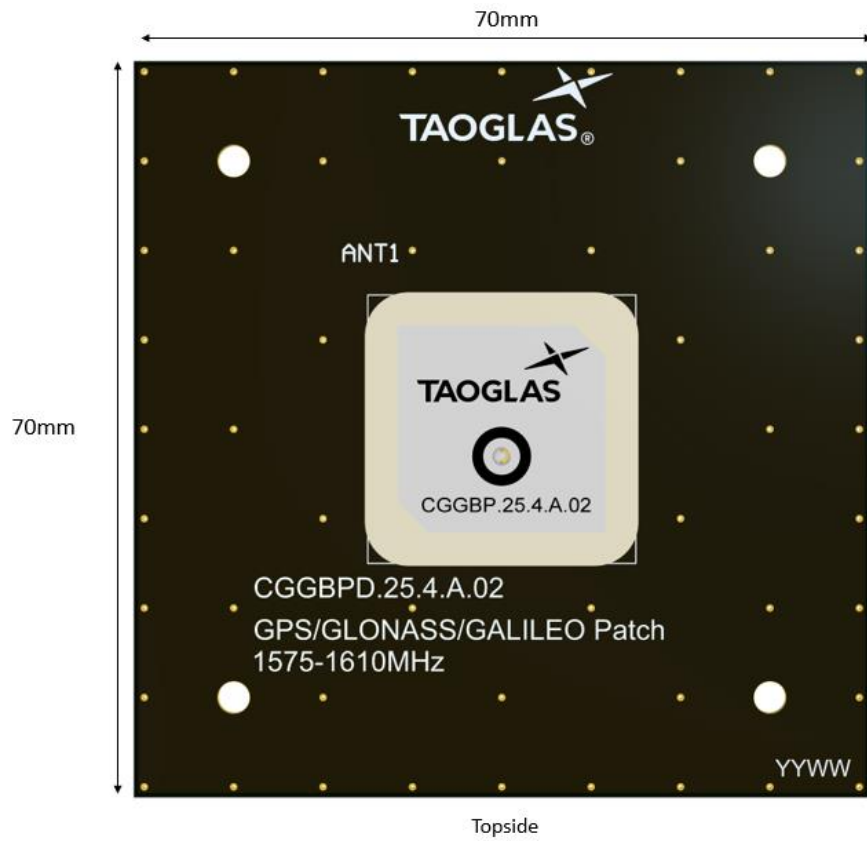

7. Footprint

7.1 Dimensions

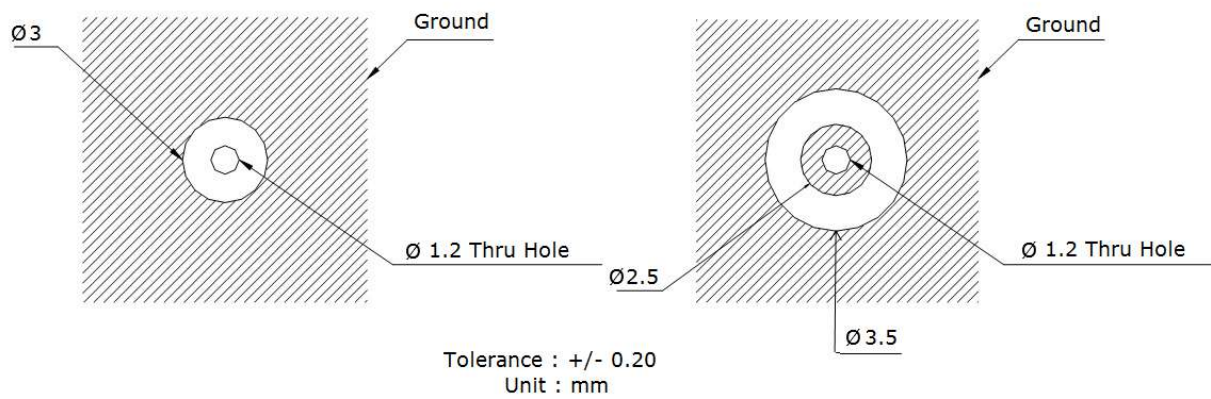

7.2 Patch on 70*70mm Ground Plane



8. Packaging

50 pcs CGGP.25.4.A.02 per tray
Tray Dimensions - 255*145*32mm

Weight - 220g

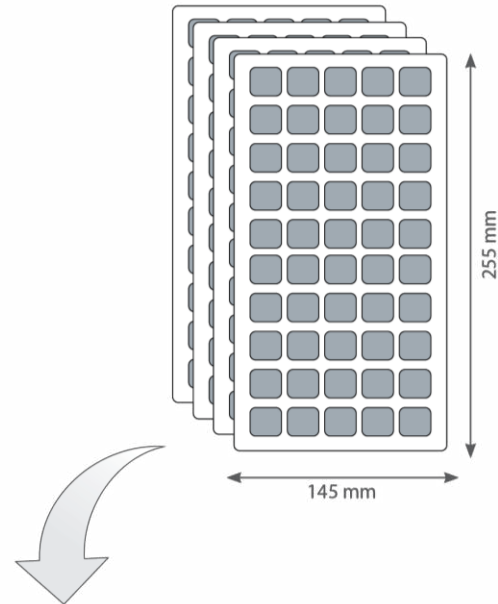

200 pcs CGGP.25.4.A.02 per Inner Carton
Inner Carton Dimensions - 261*152*118mm

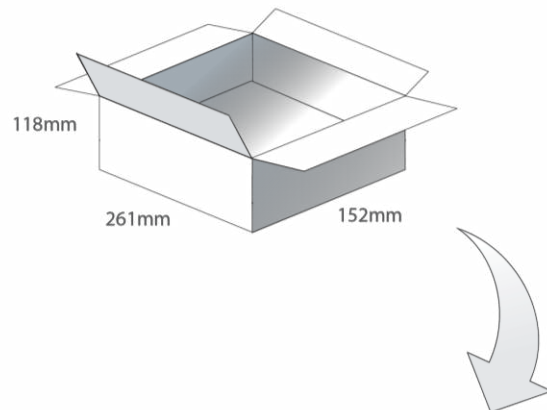

800 pcs CGGP.25.A.E.02 per Carton
Carton Dimensions - 370*370*300mm

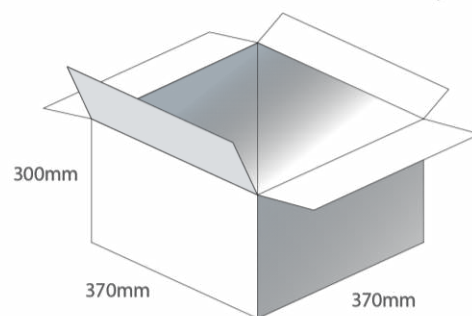

Changelog for the datasheet

SPE-14-8-071 – CGGBP.25.4.A.02

Revision: F (Current Version)

Date:	2023-02-21
Changes:	Updated GNSS Bands & Constellations Graphics and Integration guide added
Changes Made by:	Cesar Sousa

Previous Revisions

Revision: E

Date:	2022-02-18
Changes:	Updated Datasheet Template Updated Packaging Graphic
Changes Made by:	Paul Doyle

Revision: C

Date:	2017-03-08
Changes:	Packaging Details Updated
Changes Made by:	Andy Mahoney

Revision: B

Date:	2017-08-17
Changes:	Packaging Details Updated
Changes Made by:	Andy Mahoney

Revision: A (Original First Release)

Date:	2017-08-10
Notes:	
Author:	Your Name Here



TAOGLAS®

www.taoglas.com

