

DESCRIPTION

Demonstration circuit 1345 is a wide input voltage range, no R_{sense} step-down dc/dc converter featuring the LTC3879EMSE. Its output voltage is 1.2V with a load rating of 12A and the input voltage range is 4.5V to 34V.

The fixed on-time valley current mode architecture of the LTC3879EMSE provides a very fast load step response. Other features of the board include a RUN pin, a TRACK pin, a PGOOD pin and a MODE jumper to select either CCM or DCM operation at light load.

Design files for this circuit board are available. Call the LTC factory.

Table 1. Performance Summary (T_A = 25 °C)

PARAMETER	CONDITION	VALUE
Minimum Input Voltage		4.5V
Maximum Input Voltage		34V
Output Voltage V _{OUT}	V _{IN} = 4.5V to 34V, I _{OUT} = 0A to 12A	1.2V ±2%
Maximum Output Current		12A
Typical Output Voltage Ripple	V _{IN} = 12V, I _{OUT} = 12A (20MHz BW)	20mV _{P-P}
Nominal Switching Frequency	V _{IN} = 12V, I _{OUT} = 12A	300kHz
Efficiency (see Figure 3 for efficiency curves)	V _{IN} = 12V, I _{OUT} = 12A	90% Typical

QUICK START PROCEDURE

Demonstration circuit 1345 is easy to set up to evaluate the performance of the LTC3879EMSE. Refer to Figure 1 for proper measurement equipment setup and follow the procedure below:

NOTE: When measuring the output voltage ripple, care must be taken to avoid a long ground lead on the oscilloscope probe. See Figure 2 for proper scope probe technique. Short, stiff leads should be soldered to the (+) and (-) terminals of an output capacitor. The probe's ground ring needs to touch the (-) lead and the probe tip needs to touch the (+) lead.

- Place jumpers in the following positions:

RUN	ON
MODE	CCM
- With power off, connect the input power supply to Vin and GND.
- Turn on the power at the input.
- Check for the proper output voltages.
V_{out} = 1.176V to 1.224V
- Once the proper output voltages are established, adjust the loads within the operating range and observe the output voltage regulation, ripple voltage, efficiency and other parameters.

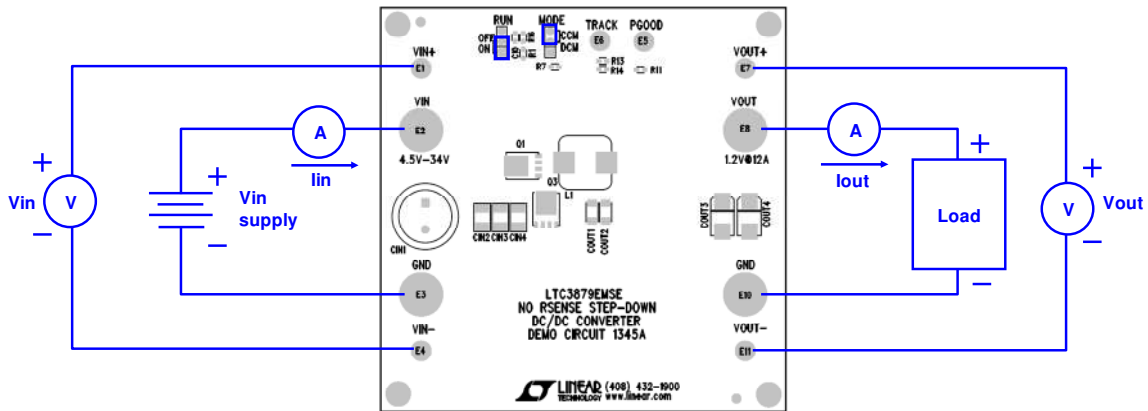

Figure 1. Proper Measurement Equipment Setup

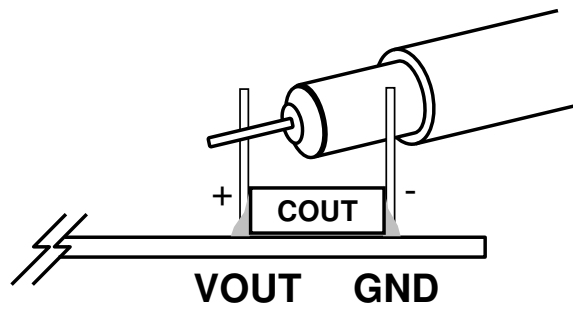
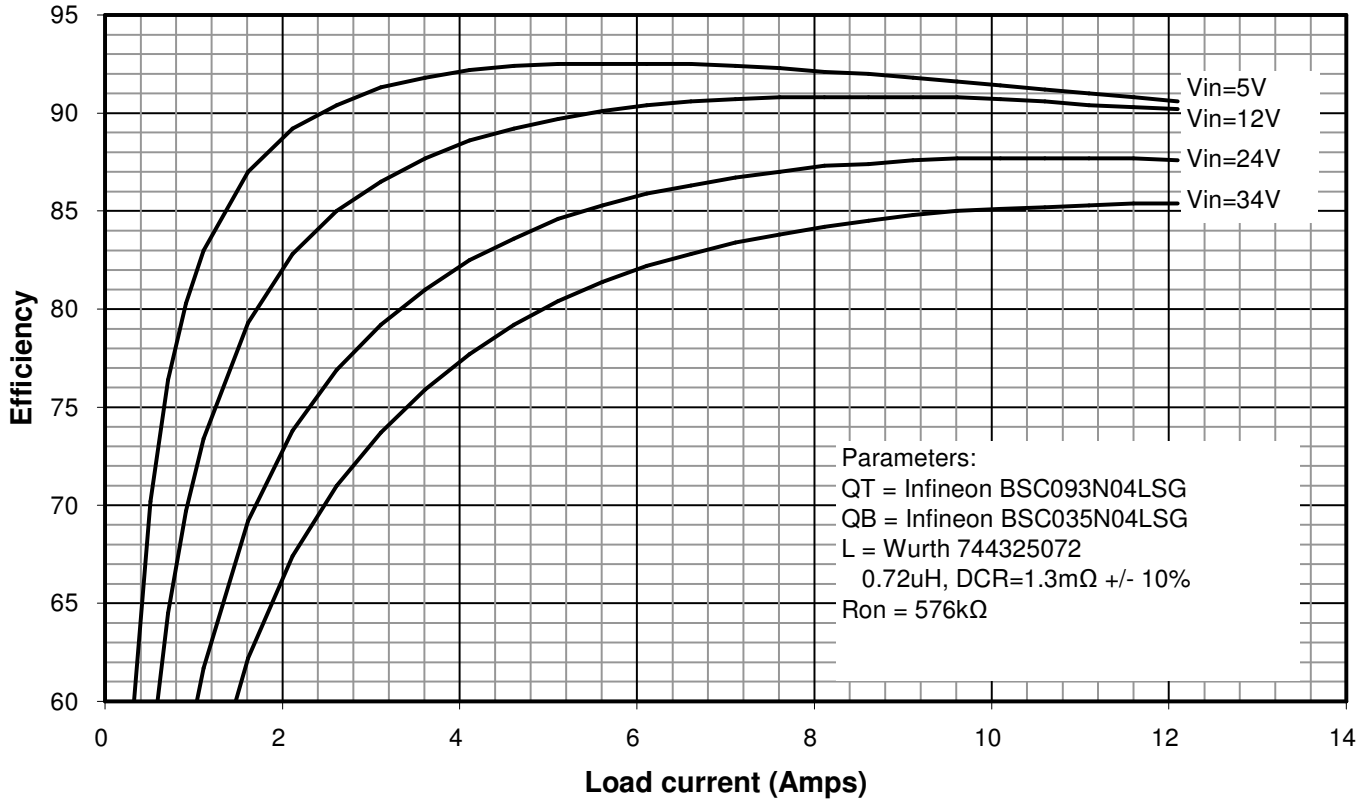
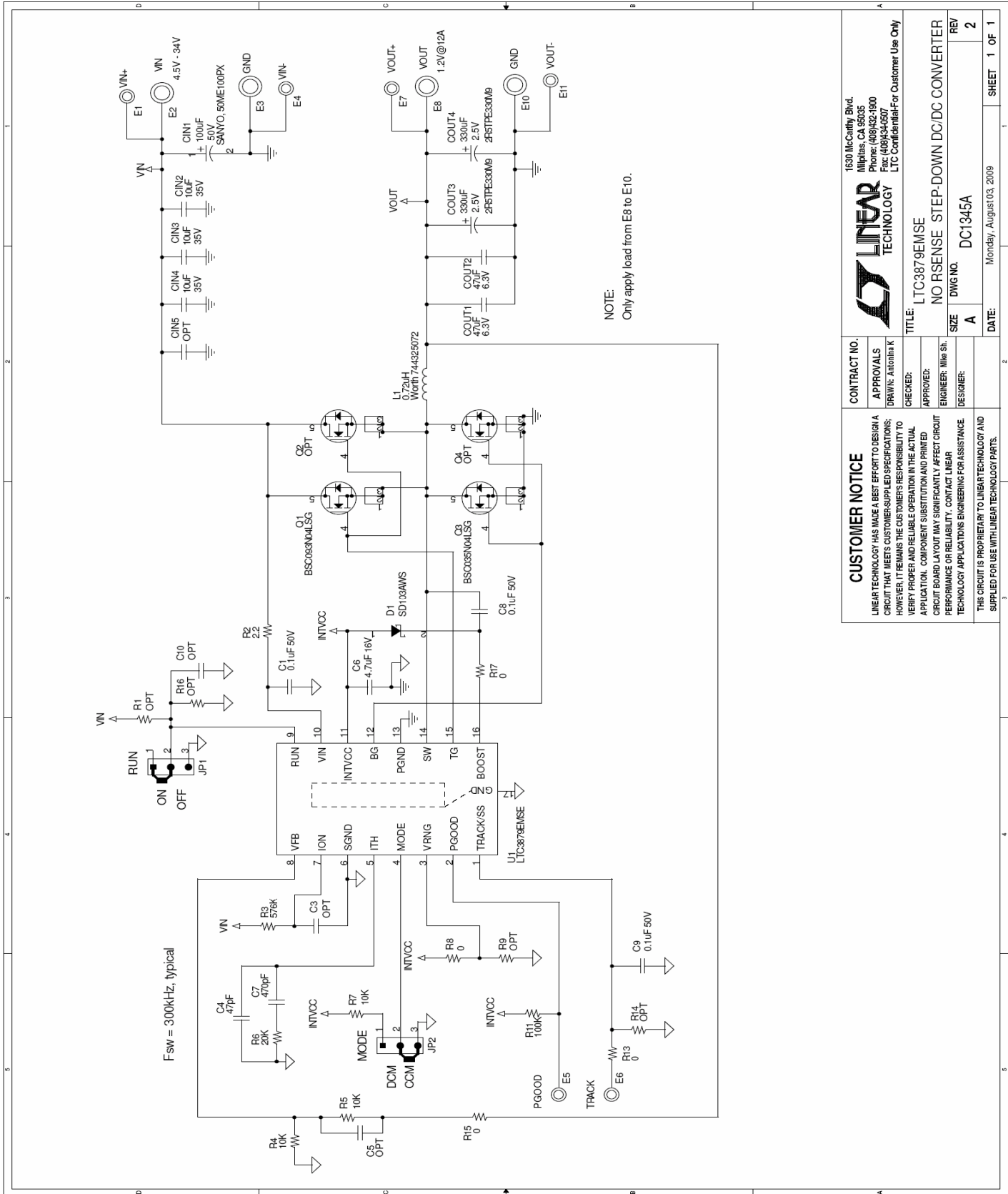

Figure 2. Measuring Output Voltage Ripple

F_{sw} = 300kHz, CCM

Figure 3. Typical Efficiency Curves



CUSTOMER NOTICE		CONTRACT NO.	
LINEAR TECHNOLOGY HAS MADE A BEST EFFORT TO DESIGN A CIRCUIT THAT MEETS CUSTOMER-SUPPLIED SPECIFICATIONS; HOWEVER, IT REMAINS THE CUSTOMER'S RESPONSIBILITY TO VERIFY PROPER AND RELIABLE OPERATION IN THE ACTUAL APPLICATION. COMPONENT SUBSTITUTION AND PRINTED CIRCUIT BOARD LAYOUT MAY SIGNIFICANTLY AFFECT CIRCUIT PERFORMANCE OR RELIABILITY. CONTACT LINEAR TECHNOLOGY APPLICATIONS ENGINEERING FOR ASSISTANCE.		APPROVALS	
THIS CIRCUIT IS PROPRIETARY TO LINEAR TECHNOLOGY AND SUPPLIED FOR USE WITH LINEAR TECHNOLOGY PARTS.		DRAWN: Antonia K	
		CHECKED:	
		APPROVED:	
		ENGINEER: Mike Shi	
		DESIGNER:	
		TITLE: LTC3879EINSE	
		NO RSENSE STEP-DOWN DC/DC CONVERTER	
		SIZE DWG NO. DC1345A	
		REV 2	
		DATE: Monday, August 03, 2009	
		SHEET 1 OF 1	