

# LC898111AXB



ON Semiconductor®

www.onsemi.com

CMOS LSI

## Optical Image Stabilization (OIS) Controller & Driver

### Overview

The LC898111AXB is Optical Image Stabilization (OIS) system control LSI for smartphone camera modules.

The LSI have built-in digital signal processing circuits, such as a 2ch saturation H-Bridge Driver and a Flexible Filter circuit, and control VCM type actuators.

The LC898111AXB is identical LSI except for the dimensions, i.e. XB has WLP thickness, max. 0.69 mm with B/C.

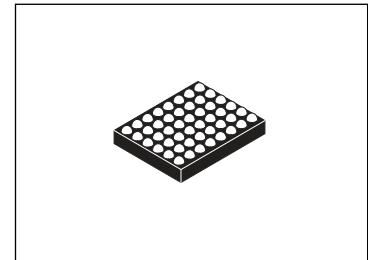

WLCSP48, 3.22x2.57

### Function

#### ■ Digital signal processing LSI (Logic LSI)

- Built-in digital servo circuit
- Built-in Gyro filter
- AD converter
  - 12-bit
  - input 5ch
  - Equipped with a sample-hold circuit
- DA converter
  - 8-bit
  - Output 2ch (Constant current Bias : max 7mA)
- Built-in Serial I/F circuit  
(2-wire I<sup>2</sup>C-Bus or 4-wire SPI Bus interface)
- Built-in Hall Bias circuit
- Built-in Hall Amp  
(Gain of Opamp : x25, x50, x75, x100, x150, x200)
- Built-in OSC (Oscillator)  
48MHz ± 5% (Frequency adjustment function)
- External Clock input is possible  
from TSTCLK (48MHz ± 5%)
- Built-in LDO (Low Drop-Out regulator)
- Digital Gyro I/F for the companies (SPI Bus)  
(Please refer for the details)
- Support Hall sensor and Photo Reflector as means  
to detect a position

#### ■ Motor Driver

- Saturation-drive H bridge x2ch
- I<sub>Q</sub> max : 220mA

#### ■ Package

- WLCSP48, 3.22mm x 2.57mm,  
thickness max 0.69mm, with B/C
- Pb-Free
- Halogen Free

#### ■ Power supply voltage

- Logic : DVDD30 = 2.6 to 3.6 V
- Driver : VM = 2.6 to 3.6 V

\* I<sup>2</sup>C Bus is a trademark of Philips Corporation.

### ORDERING INFORMATION

See detailed ordering and shipping information on page 6 of this data sheet.

Block Diagram

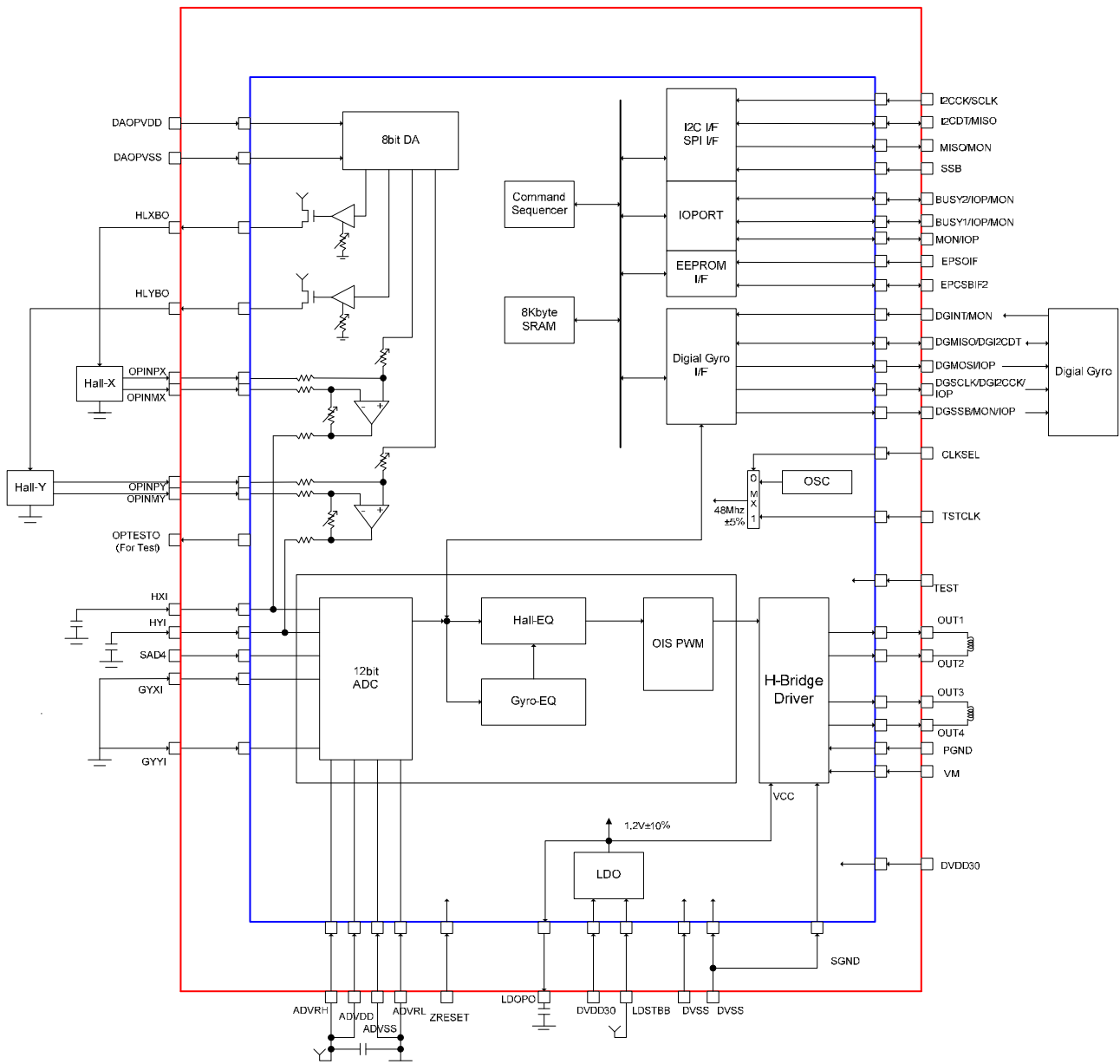

Figure 3.1 Example of wiring diagram (Hall) in LC898111AXB

Package Dimensions

unit : mm

WLCSP48, 3.22x2.57

CASE 567GE

ISSUE O

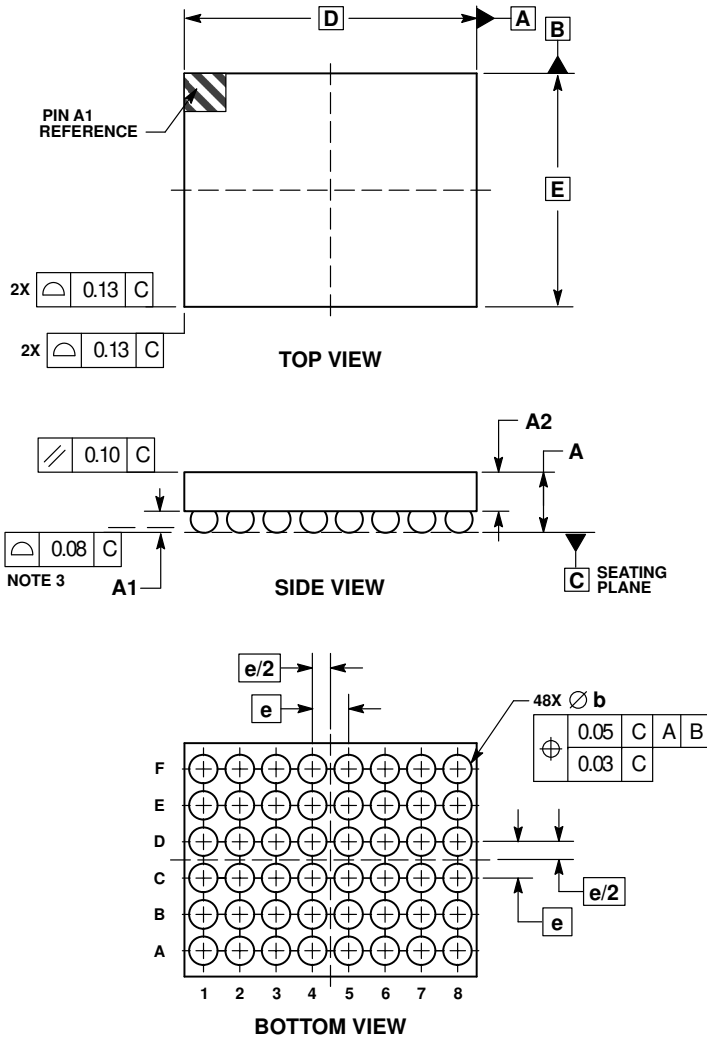

NOTES:

1. DIMENSIONING AND TOLERANCING PER ASME Y14.5M, 1994.
2. CONTROLLING DIMENSION: MILLIMETERS.
3. COPLANARITY APPLIES TO SPHERICAL CROWNS OF SOLDER BALLS.

DIM	MILLIMETERS	
	MIN	MAX
A	---	0.69
A1	0.16	0.26
A2	0.43 REF	
b	0.21	0.31
D	3.22 BSC	
E	2.57 BSC	
e	0.40 BSC	

GENERIC MARKING DIAGRAM\*

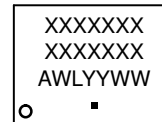

- XXXXXXX = Device Code
- A = Assembly Location
- WL = Wafer Lot
- YY = Year
- WW = Work Week
- = Pb-Free Package

\*This information is generic. Please refer to device data sheet for actual part marking.

RECOMMENDED SOLDERING FOOTPRINT\*

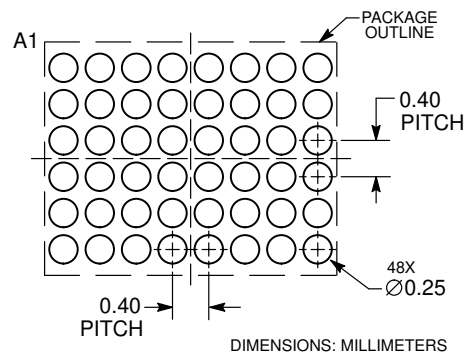







\*For additional information on our Pb-Free strategy and soldering details, please download the ON Semiconductor Soldering and Mounting Techniques Reference Manual, SOLDERRM/D.

Pin Assignment

Top View

1	OPTESTO	OPINPY	ADVDD	ADVSS	GYI	HXI
2	HLXBO	OPINMY	ADVRH	GYXI	DVSS	I2CDT
3	EPSOIF	DAOPVDD	ADVRL	HYI	EPCSBIF2	I2CCK
4	DVDD30	DAOPVSS	OPINPX	SAD4	SSB	MISO
5	BUSY2	HLYBO	OPINMX	ZRESET	LDOPO	DVDD30
6	BUSY1	TEST	DVSS	TSTCLK	LDSTBB	DGCLK
7	VM	MON	CLKSEL	DGMOSI	DGMISO	DGINT
8	OUT4	OUT3	OUT2	OUT1	PGND	DGSSB
	F	E	D	C	B	A

 Driver  
 DAC  
 OpAmp  
 ADC

 EEPROM i/f  
 Logic GND  
 IO VDD (2.6V to 3.6V)  
 Logic Core VDD (1.14 to 1.26V)

# LC898111AXB

<typ> I : INPUT, O : OUTPUT, B : BIDIRECTION, P : Power, GND

Ball No	Pin Name	type	Description
F8	OUT4	O	Driver Output
F7	VM	P	Driver VDD (2.6V to 3.6V)
F6	BUSY1	B	EEPROM I/F (at I <sup>2</sup> C type EEPROM ) / BUSY1(O) / General-purpose IOPORT(B) / inner signal Monitor(O)
F5	BUSY2	B	BUSY2(O) / General-purpose IOPORT(B) / inner signal Monitor(O)
F4	DVDD30	P	Logic IO VDD (2.6V to 3.6V)
F3	EPSOIF	I	EEPROM I/F
F2	HLXBO	O	Hall-X Bias (Current Drive)
F1	OPTESTO	O	OpAmp Test out
E8	OUT3	O	Driver output
E7	MON	B	inner signal monitor / General-purpose IOPORT
E6	TEST	I	SPI & External clock case sets "1" other cases set "0"
E5	HLYBO	O	Hall-Y Bias (Current Drive)
E4	DAOPVSS	P	DA&Opamp VSS
E3	DAOPVDD	P	DA&Opamp VDD (2.6V to 3.6V)
E2	OPINMY	I	Hall-Y OpAmp input-
E1	OPINPY	I	Hall-Y OpAmp input+
D8	OUT2	O	Driver Output
D7	CLKSEL	I	change pin of OSC(0) and External clock(1)
D6	DVSS	P	Logic GND
D5	OPINMX	I	Hall-X OpAmp input-
D4	OPINPX	I	Hall-X OpAmp input+
D3	ADVRL	I	ADC Reference Voltage Low input
D2	ADVRH	I	ADC Reference Voltage High input
D1	ADVDD	P	AD VDD (2.6V to 3.6V)
C8	OUT1	O	Driver Output
C7	DGMOSI	B	Digital Gyro (4-wire)IF data(O) / HPS Control(O) / General-purpose IOPORT(B)
C6	TSTCLK	I	CLKSEL=1 : External Clock, CLKSEL=0 : change pin of I <sup>2</sup> C(0) and SPI(1)
C5	ZRESET	I	Hard Wafer Reset
C4	SAD4	I	General-purpose AD input
C3	HYI	I	Hall-Y AD input
C2	GYXI	I	Gyro-X AD input
C1	ADVSS	P	AD GND
B8	PGND	P	Driver GND
B7	DGMISO	B	Digital Gyro SPI IF Data( I ) / Digital Gyro I <sup>2</sup> C IF Data(B)
B6	LDSTBB	I	LDO Standby (0 : Standby On, 1 : Standby Off)
B5	LDOPO	P	LDO Power supply out (Logic Core VDD (1.14V to 1.26V))
B4	SSB	I	SPI I/F Chip Select / VDD fix at I <sup>2</sup> C i/f
B3	EPCSIF2	B	EEPROM I/F
B2	DVSS	P	Logic GND
B1	GYXI	I	Gyro-Y AD input
A8	DGSSB	B	Digital Gyro SPI IF Chip Select(O) / inner signal monitor(O) / General-purpose IOPORT(B)
A7	DGINT	B	Digital Gyro SPI IF Data Busy( I ) / inner signal monitor(O) / General-purpose IOPORT(B)
A6	DGCLK	B	Digital Gyro SPI IF clock (O) / Digital Gyro I <sup>2</sup> C IF clock(O) / HPS Control 1(O) / General-purpose IOPORT (B)
A5	DVDD30	P	Logic IO VDD (2.6V to 3.6V) and power supply to LDO
A4	MISO	O	SPI I/F Data / General-purpose IOPORT / inner signal monitor
A3	I2CCK	I	I <sup>2</sup> C IF clock / SPI IF clock
A2	I2CDT	B	I <sup>2</sup> C IF Data(B) / SPI IF Data
A1	HXI	I	Hall-X AD input

## ORDERING INFORMATION

Device	Package	Shipping (Qty / Packing)
LC898111AXB-MH	WLCSP48, 3.22x2.57 (Pb-Free / Halogen Free)	4000 / Tape & Reel

† For information on tape and reel specifications, including part orientation and tape sizes, please refer to our Tape and Reel Packaging Specifications Brochure, BRD8011/D. [http://www.onsemi.com/pub\\_link/Collateral/BRD8011-D.PDF](http://www.onsemi.com/pub_link/Collateral/BRD8011-D.PDF)

ON Semiconductor and the ON logo are registered trademarks of Semiconductor Components Industries, LLC (SCILLC) or its subsidiaries in the United States and/or other countries. SCILLC owns the rights to a number of patents, trademarks, copyrights, trade secrets, and other intellectual property. A listing of SCILLC's product/patent coverage may be accessed at [www.onsemi.com/site/pdf/Patent-Marking.pdf](http://www.onsemi.com/site/pdf/Patent-Marking.pdf). SCILLC reserves the right to make changes without further notice to any products herein. SCILLC makes no warranty, representation or guarantee regarding the suitability of its products for any particular purpose, nor does SCILLC assume any liability arising out of the application or use of any product or circuit, and specifically disclaims any and all liability, including without limitation special, consequential or incidental damages. "Typical" parameters which may be provided in SCILLC data sheets and/or specifications can and do vary in different applications and actual performance may vary over time. All operating parameters, including "Typicals" must be validated for each customer application by customer's technical experts. SCILLC does not convey any license under its patent rights nor the rights of others. SCILLC products are not designed, intended, or authorized for use as components in systems intended for surgical implant into the body, or other applications intended to support or sustain life, or for any other application in which the failure of the SCILLC product could create a situation where personal injury or death may occur. Should Buyer purchase or use SCILLC products for any such unintended or unauthorized application, Buyer shall indemnify and hold SCILLC and its officers, employees, subsidiaries, affiliates, and distributors harmless against all claims, costs, damages, and expenses, and reasonable attorney fees arising out of, directly or indirectly, any claim of personal injury or death associated with such unintended or unauthorized use, even if such claim alleges that SCILLC was negligent regarding the design or manufacture of the part. SCILLC is an Equal Opportunity/Affirmative Action Employer. This literature is subject to all applicable copyright laws and is not for resale in any manner.