



Features

- Single 3-V Supply Voltage
- High Power-added Efficient Power Amplifier (P_{out} typically 26.5 dBm)
- Ramp-controlled Output Power
- Low-noise Preamplifier (NF typically 1.8 dB)
- Biasing for External PIN Diode T/R Switch
- Current-saving Standby Mode
- Few External Components

Electrostatic sensitive device.
Observe precautions for handling.



DECT SiGe Front End IC

U7004B

Description

The U7004B is a monolithic SiGe transmit/receive front end IC with power amplifier, 50- Ω internal matching, low-noise amplifier and T/R switch driver. It is especially designed for operation in TDMA systems like DECT. Due to the ramp-control feature and a very low quiescent current, an external switch transistor for V_S is not required.

Figure 1. Block Diagram

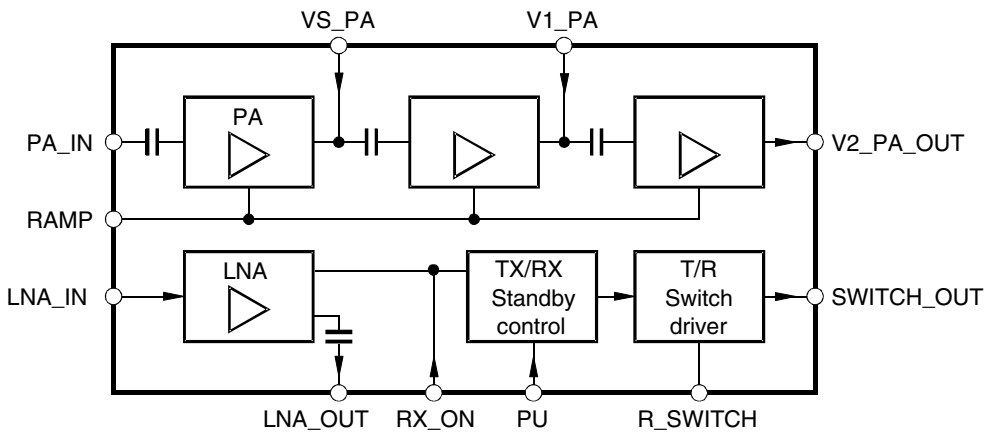

Pin Configuration

Figure 2. Pinning SSO20

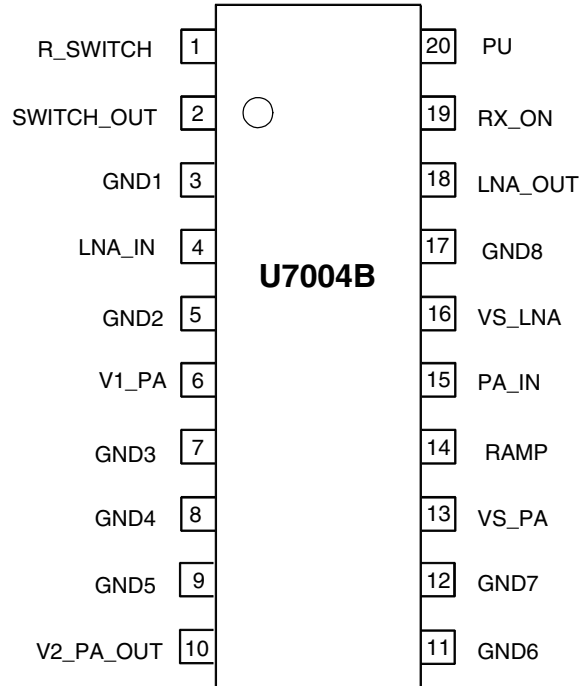

Pin Description

Pin	Symbol	Function
1	R_SWITCH	Resistor to GND sets the PIN diode current
2	SWITCH_OUT	Switched current output for PIN diode
3	GND1	Ground
4	LNA_IN	Low-noise amplifier input
5	GND2	Ground
6	V1_PA	Inductor to power supply for power amplifier
7	GND3	Ground
8	GND4	Ground
9	GND5	Ground
10	V2_PA_OUT	Inductor to power supply and matching network for power amplifier output
11	GND6	Ground
12	GND7	Ground
13	VS_PA	Supply voltage for power amplifier
14	RAMP	Power-ramping control input
15	PA_IN	Power amplifier input
16	VS_LNA	Supply-voltage input for low-noise amplifier
17	GND8	Ground
18	LNA_OUT	Low-noise amplifier output
19	RX_ON	RX active high
20	PU	Power-up active high

Absolute Maximum Ratings

All voltages refer to GND (pins 3, 5, 7, 8, 9, 11, 12 and 17), ESD protection according to ESD-S5.2-1994, Class M1.

Parameters	Symbol	Value	Unit
Supply voltage pins 6, 10, 13 and 16 (no RF)	V_S	5	V
Duty cycle PA		50	%
Burst duration PA		5	ms
Junction temperature	T_j	150	°C
Storage temperature	T_{stg}	-40 to +125	°C
Input power PA pin 15	P_{inPA}	+10	dBm
Input power LNA pin 4	P_{inLNA}	-5	dBm

Thermal Resistance

Parameters	Symbol	Value	Unit
Junction ambient	R_{thJA}	95	K/W

Operating Range

All voltages refer to GND (Pins 3, 5, 7, 8, 9, 11, 12 and 17). The following table represents the sum of all supply currents depending on the TX/RX mode. Power supply points are VS_LNA, VS_PA, V1_PA, V2_PA_OUT.

Parameters	Symbol	Min.	Typ.	Max.	Unit
Supply voltage pins 6, 10 and 13	V_S	2.7	3.6	4.6	V
Supply voltage pin 16	V_S	2.7	3.6	4.6	V
Supply current TX	I_S		450		mA
RX	I_S		8		mA
Standby current PU = 0	I_S		10		µA
Ambient temperature	T_{amb}	-25	+25	+70	°C

Electrical Characteristics

Test conditions (unless otherwise specified): $V_S = 3.6\text{ V}$, $T_{amb} = 25^\circ\text{C}$, pulsed mode, duty cycle 4.17%, $t_{on} = 417\ \mu\text{s}$

Parameters	Test Conditions	Symbol	Min.	Typ.	Max.	Unit
Power Amplifier ⁽¹⁾						
Supply voltage	Pins 6, 10 and 13	V_S	2.7	3.6	4.6	V
Supply current	TX	I_{S_TX}		450		mA
Supply current	RX (PA off)	I_{S_RX}			10	µA
Standby current	Standby	$I_{S_standby}$			10	µA
Frequency range	TX	f	1.88		1.94	GHz
Power gain	TX, pin 15 to pin 10	Gp		28		dB
Gain-control range	TX	ΔGp		48		dB

- Notes:
- Power amplifier shall be unconditionally stable, maximum duty cycle 50%, maximum load mismatch and duration: load VSWR = 20:1 (all phases) 10 s, $Z_G = 50\ \Omega$
 - With external matching network (see Figure 13 and Figure 14)
 - Low-noise amplifier shall be unconditionally stable

Electrical Characteristics (Continued)

Test conditions (unless otherwise specified): $V_S = 3.6\text{ V}$, $T_{\text{amb}} = 25^\circ\text{C}$, pulsed mode, duty cycle 4.17%, $t_{\text{on}} = 417\ \mu\text{s}$

Parameters	Test Conditions	Symbol	Min.	Typ.	Max.	Unit
Ramping voltage	TX, power gain (max), pin 14	$V_{\text{RAMP max}}$		2.1		V
Ramping current	TX, power gain (max), pin 14	I_{RAMP}		0.5	2.0	mA
Power-added efficiency	TX	PAE		30		%
Saturated output power	TX, refer to pin 10	P_{sat}		26.5		dBm
Input matching ⁽²⁾	TX, pin 15	VSWRin		< 2:1		
Output matching ⁽²⁾	TX, pin 10	VSWRout		< 2:1		
Harmonics at P 1dB	TX, pin 10	2 fo 3 fo		-30		dBc
Maximum input power	Pin 15	P_{inPA}		10		dBm
Stability (non harmonic emission)	TX, pin 10 $P_{\text{in}} = 2\ \text{dBm}$, $V_{\text{RAMP}} = 2\ \text{V}$ VSWRout < 10:1 (all phases)			-60		dBc
T/R Switch Driver (Currently Programmed by External Resistor from R_SWITCH to GND)						
Switch-out current output	Standby, pin 2	$I_{\text{S}_O_standby}$			2	μA
Switch-out current output	RX	$I_{\text{S}_O_RX}$			2	μA
Switch-out current output	TX at 100 Ω	$I_{\text{S}_O_100}$		1		mA
Switch-out current output	TX at 1.2 k Ω	$I_{\text{S}_O_1k2}$		3		mA
Switch-out current output	TX at 33 k Ω	$I_{\text{S}_O_33k}$		10		mA
Low-noise Amplifier ⁽³⁾						
Supply voltage	All, pin 16	V_S	2.7	3.6	4.6	V
Supply current	RX	I_S		8		mA
Supply current (LNA and control logic)	TX (control logic active), pin 16	I_S		300		μA
Standby current	Standby, pin 16	I_S		1	10	μA
Frequency range	RX	f	1.88		1.94	GHz
Power gain	RX, pin 4 to pin 18	Gp	17	19		dB
Noise figure	RX	NF		1.8	2.0	dB
Gain compression	RX, refer to pin 18	P1dB		-7		dBm
3rd-order input interception point	RX	IIP3		-15		dBm
Input matching	RX	VSWRin		< 2:1		
Output matching	RX	VSWRin		< 2:1		
Logic Input Levels (RX_ON, PU)						
High input level	= 1, pins 19 and 20	V_{iH}	2.4		V_S	V
Low input level	= 0	V_{iL}	0		0.5	V
High input current	= 1	I_{iH}		40		μA
Low input current	= 0	I_{iL}		0		μA

Notes: 1. Power amplifier shall be unconditionally stable, maximum duty cycle 50%, maximum load mismatch and duration: load VSWR = 20:1 (all phases) 10 s, $Z_G = 50\ \Omega$

2. With external matching network (see Figure 13 and Figure 14)

3. Low-noise amplifier shall be unconditionally stable

Control Logic

Table 1. Control Logic for LNA and T/R Switch Driver

Operation Mode	PU	RX_ON
Standby	0	0
TX	1	0
RX	1	1

Figure 3. Output Power versus Ramp Voltage

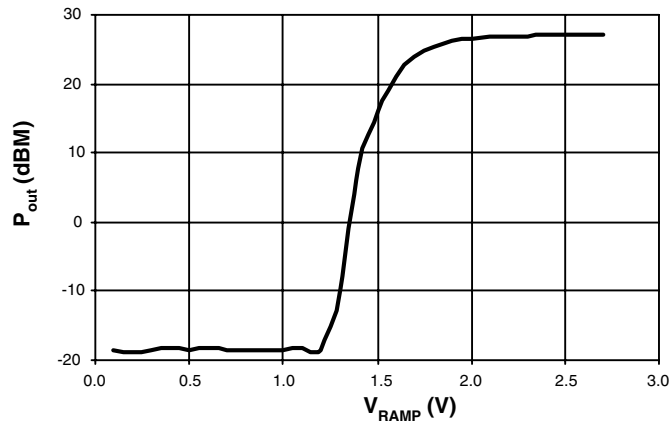

Input/Output Circuits

Figure 4. Input Circuit PA_IN/VS_PA

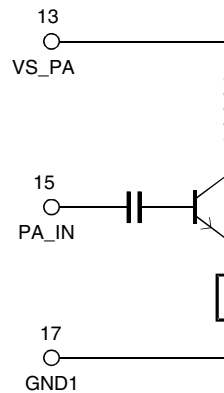

Figure 5. Input Circuit RAMP/VS_PA

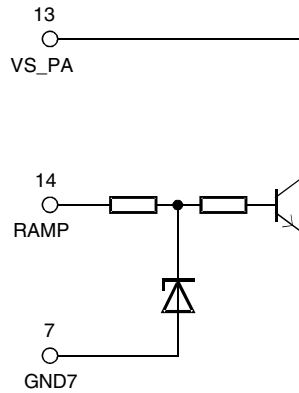

Figure 6. Input Circuit V1_PA

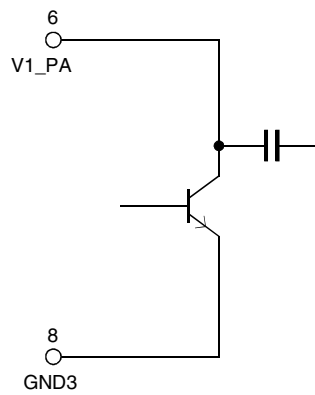

Figure 7. Input/Output Circuit V2_PA

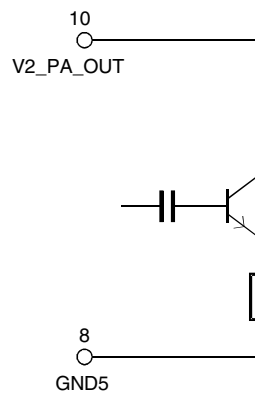

Figure 8. Input Circuit LNA_IN/VS_LNA

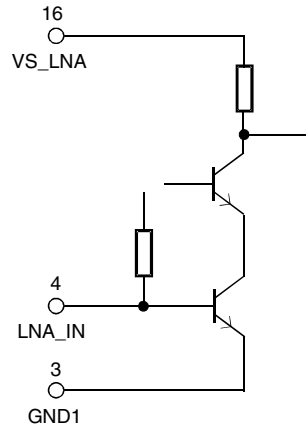

Figure 9. Output Circuit LNA_OUT

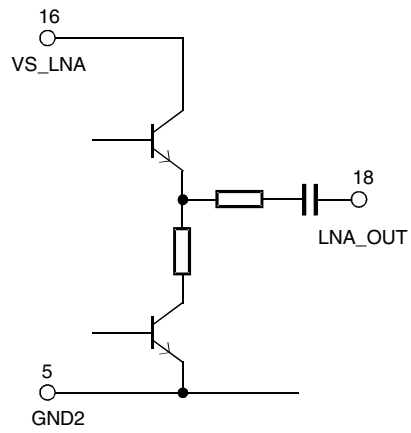

Figure 10. Input Circuit SWITCH_OUT/R_SWITCH

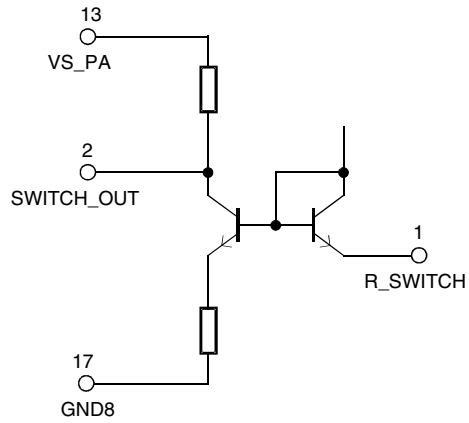

Figure 11. Input Circuit RX_ON

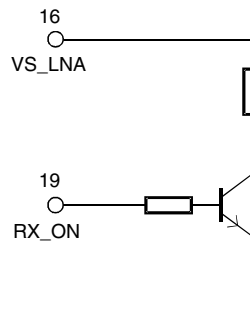
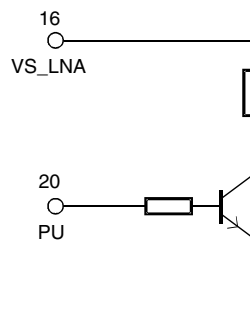

Figure 12. Input Circuit PU



Typical Application Circuit

Figure 13. Typical Schematic

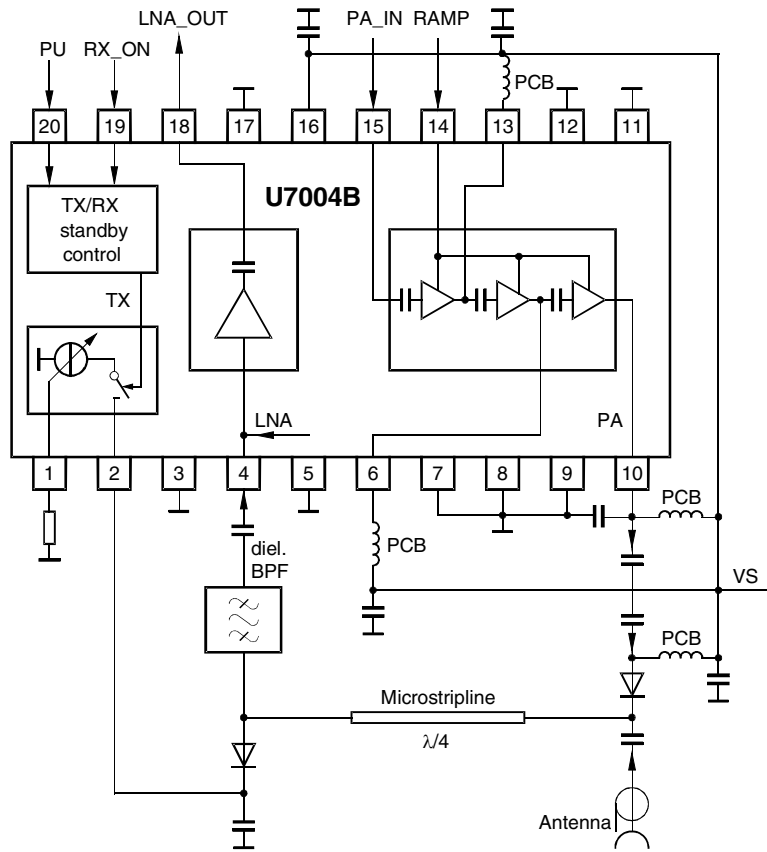

Figure 14. U7004B Application Board Schematic

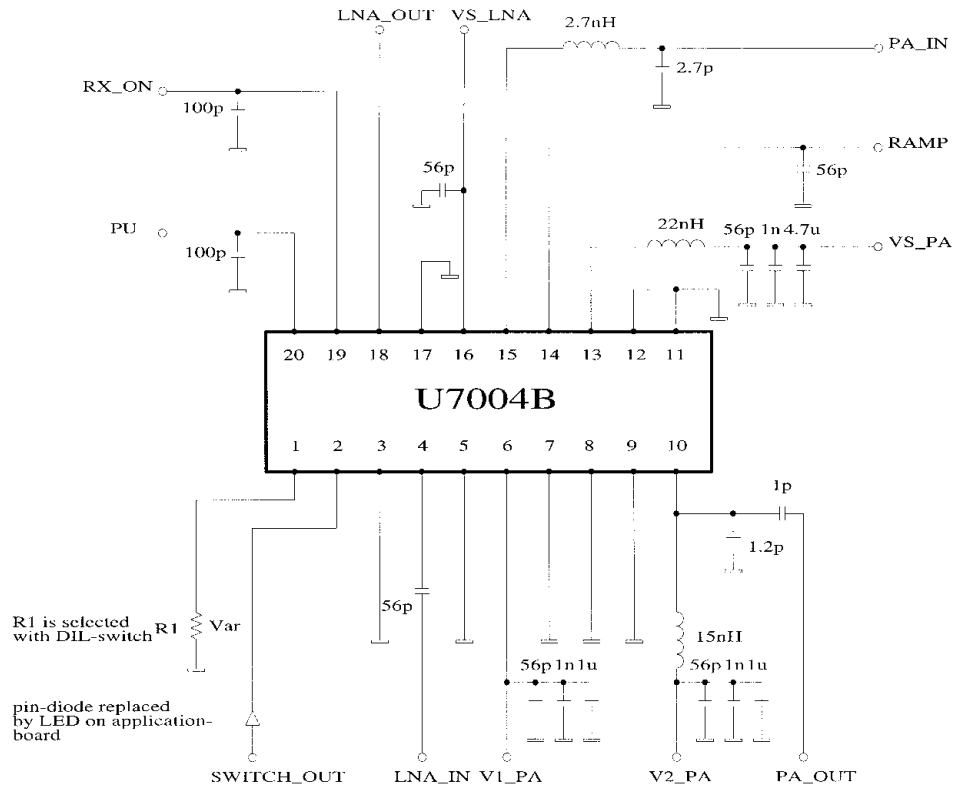
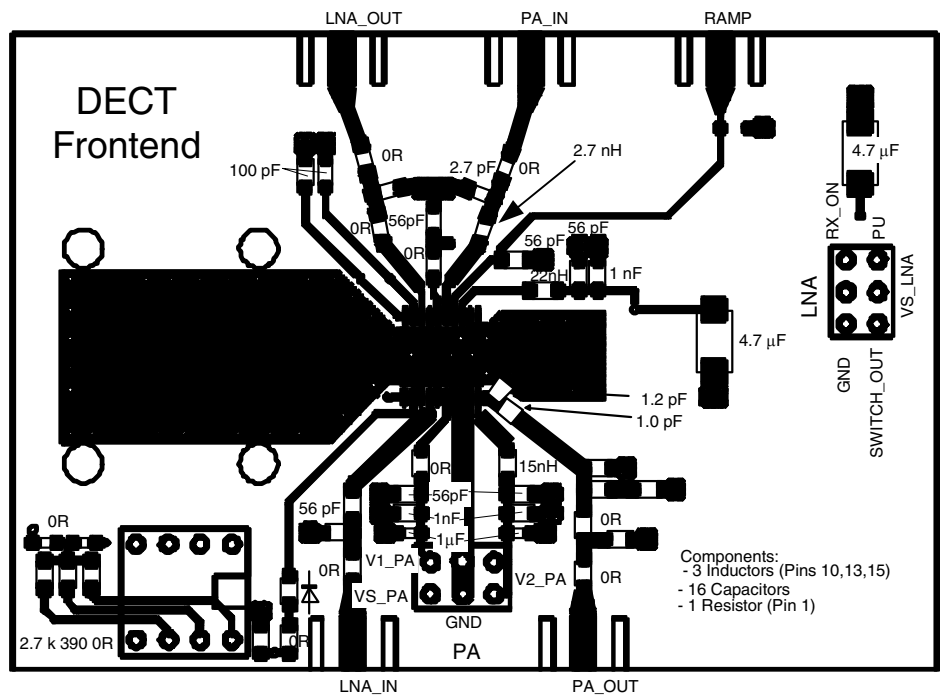

Figure 15. U7004B Application Board Layout



Ordering Information

Extended Type Number	Package	Remarks
U7004B-MFS	SSO20	Tube
U7004B-MFSG3	SSO20	Taped and reeled

Package Information

Package SSO20
Dimensions in mm

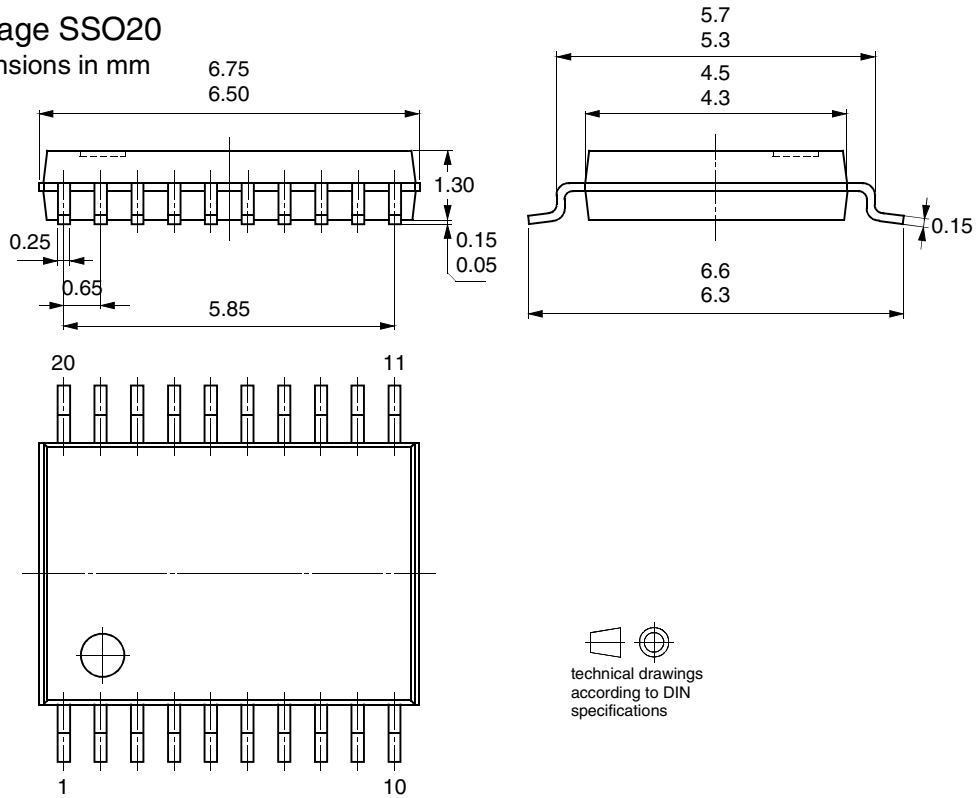

technical drawings according to DIN specifications



Atmel Corporation

2325 Orchard Parkway
San Jose, CA 95131
Tel: 1(408) 441-0311
Fax: 1(408) 487-2600

Regional Headquarters

Europe

Atmel Sarl
Route des Arsenaux 41
Case Postale 80
CH-1705 Fribourg
Switzerland
Tel: (41) 26-426-5555
Fax: (41) 26-426-5500

Asia

Room 1219
Chinachem Golden Plaza
77 Mody Road Tsimshatsui
East Kowloon
Hong Kong
Tel: (852) 2721-9778
Fax: (852) 2722-1369

Japan

9F, Tonetsu Shinkawa Bldg.
1-24-8 Shinkawa
Chuo-ku, Tokyo 104-0033
Japan
Tel: (81) 3-3523-3551
Fax: (81) 3-3523-7581

Atmel Operations

Memory

2325 Orchard Parkway
San Jose, CA 95131
Tel: 1(408) 441-0311
Fax: 1(408) 436-4314

Microcontrollers

2325 Orchard Parkway
San Jose, CA 95131
Tel: 1(408) 441-0311
Fax: 1(408) 436-4314

La Chantrerie
BP 70602
44306 Nantes Cedex 3, France
Tel: (33) 2-40-18-18-18
Fax: (33) 2-40-18-19-60

ASIC/ASSP/Smart Cards

Zone Industrielle
13106 Rousset Cedex, France
Tel: (33) 4-42-53-60-00
Fax: (33) 4-42-53-60-01

1150 East Cheyenne Mtn. Blvd.
Colorado Springs, CO 80906
Tel: 1(719) 576-3300
Fax: 1(719) 540-1759

Scottish Enterprise Technology Park
Maxwell Building
East Kilbride G75 0QR, Scotland
Tel: (44) 1355-803-000
Fax: (44) 1355-242-743

RF/Automotive

Theresienstrasse 2
Postfach 3535
74025 Heilbronn, Germany
Tel: (49) 71-31-67-0
Fax: (49) 71-31-67-2340

1150 East Cheyenne Mtn. Blvd.
Colorado Springs, CO 80906
Tel: 1(719) 576-3300
Fax: 1(719) 540-1759

Biometrics/Imaging/Hi-Rel MPU/ High Speed Converters/RF Datacom

Avenue de Rochepleine
BP 123
38521 Saint-Egreve Cedex, France
Tel: (33) 4-76-58-30-00
Fax: (33) 4-76-58-34-80

e-mail

literature@atmel.com

Web Site

<http://www.atmel.com>

Disclaimer: Atmel Corporation makes no warranty for the use of its products, other than those expressly contained in the Company's standard warranty which is detailed in Atmel's Terms and Conditions located on the Company's web site. The Company assumes no responsibility for any errors which may appear in this document, reserves the right to change devices or specifications detailed herein at any time without notice, and does not make any commitment to update the information contained herein. No licenses to patents or other intellectual property of Atmel are granted by the Company in connection with the sale of Atmel products, expressly or by implication. Atmel's products are not authorized for use as critical components in life support devices or systems.

© Atmel Corporation 2003. All rights reserved.

Atmel® and combinations thereof are the registered trademarks of Atmel Corporation or its subsidiaries.

Other terms and product names may be the trademarks of others.



Printed on recycled paper.