

Product Specification for Approval

WE ARE PLEASED IN SUBMITTING OUR SAMPLES WITH SPECIFICATION TO YOU FOR APPROVAL.

CUSTOMER	:	
DESCRIPTION	:	POWER INDUCTOR
MNC P/N	:	MHW2012SG150KA
VERSION	:	A0
CUSTOMER P/N	:	
ISSUED DATE	:	2020/6/9
PHOTO OF PRODUCT	:	
WEIGHT	:	22.8g
MADE IN	:	CHINA



APPROVED BY MNC		
PREPARED BY	CHECKED BY	APPROVED BY
Fanny	Renbo Zhu	Zhiliang Gong

APPROVED BY CUSTOMER
SIGNATURE OR STAMP

1. PLEASE SEND BACK US A COPY OF THE SPECIFICATION WITH YOUR STAMP OR SIGNATURE ONCE THE SAMPLES APPROVED.
2. IT WILL BE DEEMED THE SAMPLES TO BE APPROVED IF NO FEEDBACK.

东莞铭普光磁股份有限公司
 Add: Shipai Town, Dongguan City, Guangdong Province, China

TEL: +86-769-86921000
 FAX: +86-769-81701563

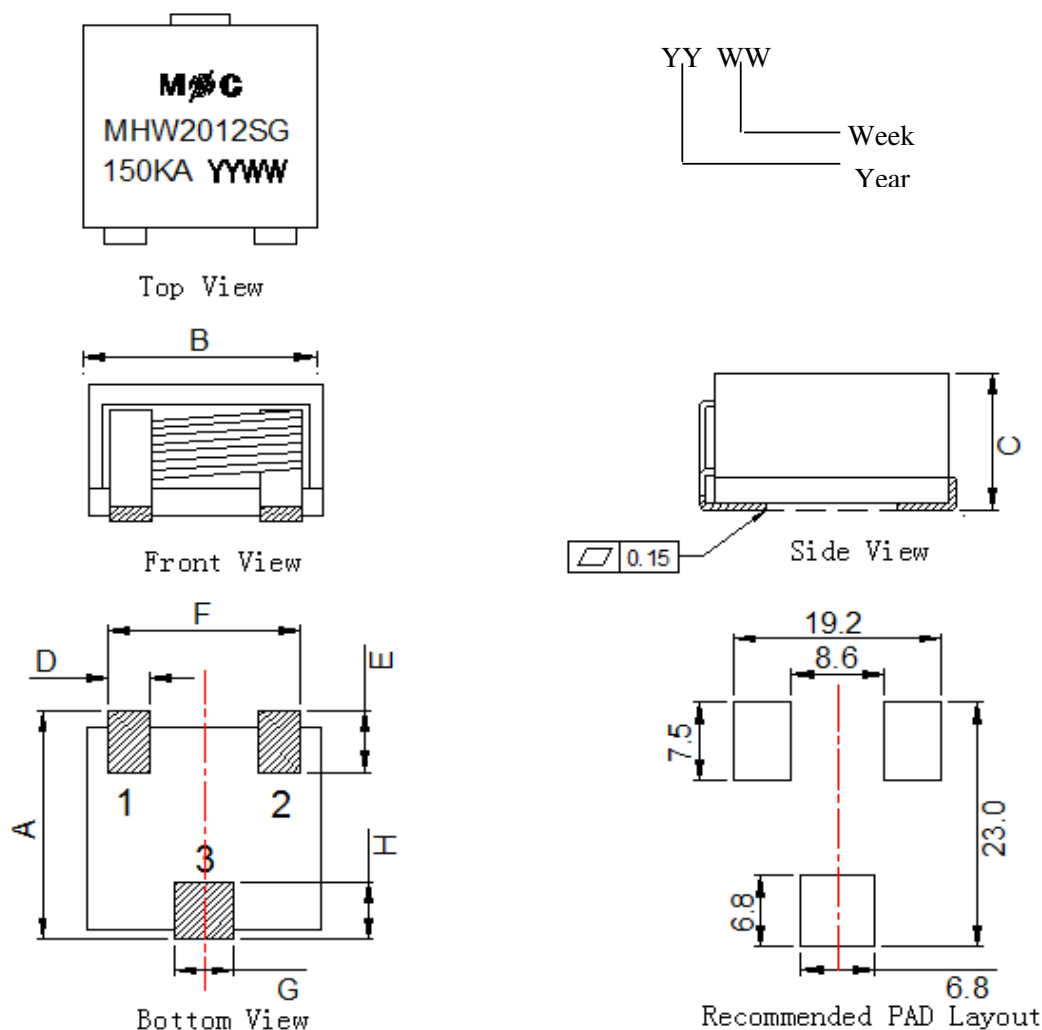
SPECIFICATION
Part No. MHW2012SG150KA
A. MECHANICAL: (UNITS: mm)

 1. Unless otherwise specified all tolerances are: $\pm 0.25\text{mm}$

2. All pin length don't include tin icicles

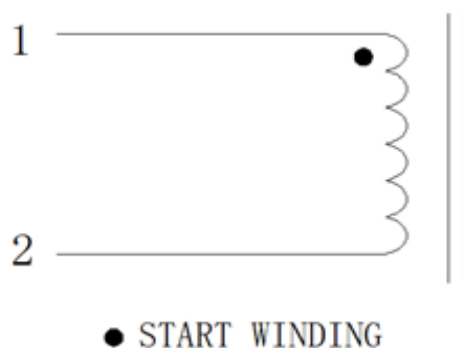
DIM	MILLIMETERS
A	22.00Max
B	22.30Max
C	12.10 ± 0.40
D	3.80 ± 0.30
E	6.00 ± 0.50
F	17.70 ± 0.50
G	5.50 ± 0.30
H	5.50 ± 0.30

SPECIFICATION
Part No. MHW2012SG150KA
B. SCHEMATIC :

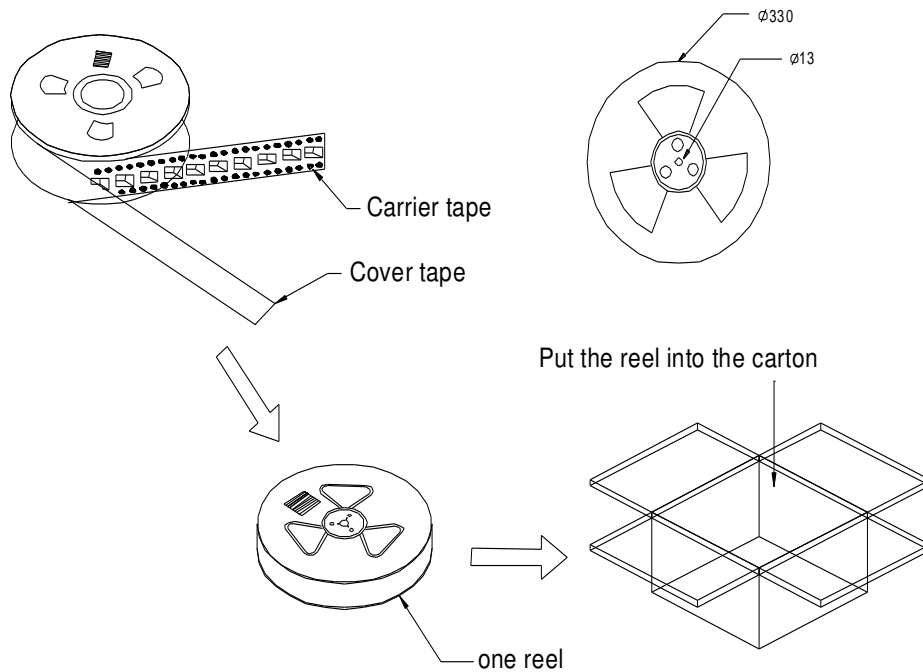
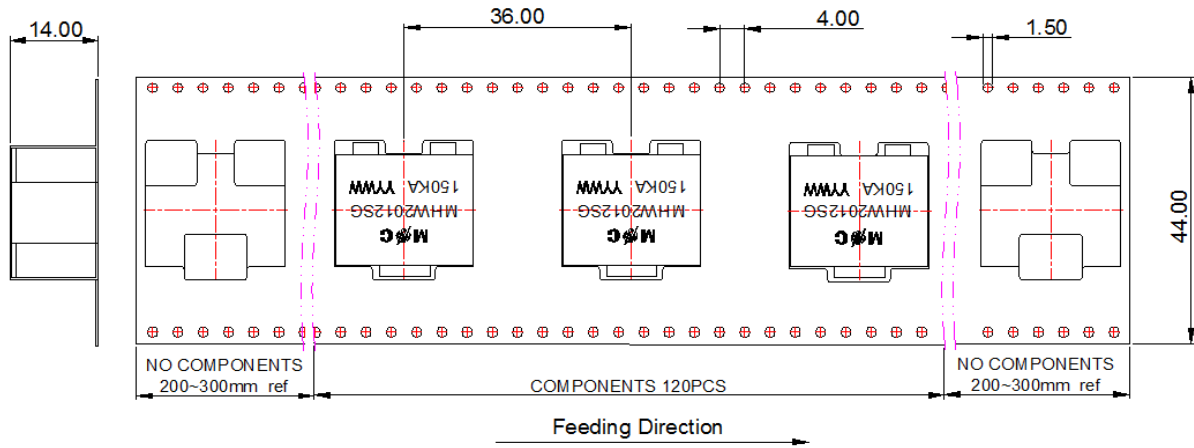
C. ELECTRICAL SPECIFICATION @25°C

ITEM	SPECIFICATION	TEST CONDITION	TEST EQUIPMENT
L: 1-2	15.0uH±10%	100KHz,1V	WK3260B OR EQU.
Isat:1-2	15.3A (L drop 20%MAX)	100KHz,1V AT 25 °C	WK3260B+3265B
Irms:1-2	10.0A	100KHz,1V AT 25 °C	WK3260B+3265B
DC RESISTANCE: 1-2	3.9mΩ Max	25°C	TH2512B OR EQU.
HI-POT: WDG-Core	200VDC	1mA,2S	TH9201S OR EQU
OPERATING TEMPERATURE RANGE	-40°C to 125°C(Including self temperature rise)		
STORAGE TEMPERATURE RANGE	-40°C to 125°C		

SPECIFICATION
Part No. MHW2012SG150KA
1. PACKING:
a. PACKAGING AS BELOW (ONLY FOR REFERENCE):

b. Q'TY:

120pcs/reel
 5 reel/carton
 600 pcs/carton

c. LABEL:

REMARK:

ABOVE PACKING IS FOR YOUR REFERENCE ONLY, WHICH MIGHT BE CHANGED WITHOUT NOTICE.

MATERIAL LIST
Part No. MHW2012SG150KA
BOM

MATERIAL LIST					
NO.	ITEM	MATERIAL	RATING	SUPPLIER OF MATERIAL	UL
1	CORE	Mn-Zn DMR96	-----	DMEGC	N/A
		Mn-Zn JNP96	-----	JIANUO	N/A
2	TAPE	PF	180°C	JINGJIANG YAHUA PRESSURE SENSITIVE GLUE CO LTD	E165111
		92	180°C	3M COMPANY ELECTRICAL MARKETS DIV (EMD)	E17385
3	PIN	C1100	-----	SHENZHEN MINGSCHIN INDUSTRIAL MATERIAL CO., LTD.	N/A
		C1100	-----	DONGGUAN CITY SHIPAI JINGHE METALS TRADE SHOP	N/A
4	EPOXY	6911 G2	-----	MIANYANG WELLS	N/A
5	Flat Wire	SFT-EI/AIWJ	220°C	WELL ASCENT ELECTRONIC (GANZHOU) CO LTD	E318511
		EI/AIW	220°C	ZHUHAI SUNTEK WIRE CO., LTD.	E234867
6	VARNISH	V1630FS	180°C	ELANTAS ELECTRICAL INSULATION ELANTAS PDG INC	E87039
		BC-346A	180°C	JOHN C DOLPH CO	E317427

RECOMMENDED SOLDERING PROFILE

Part No. MHW2012SG150KA

1. RECOMMENDED REFLOW SOLDERING PROFILE:

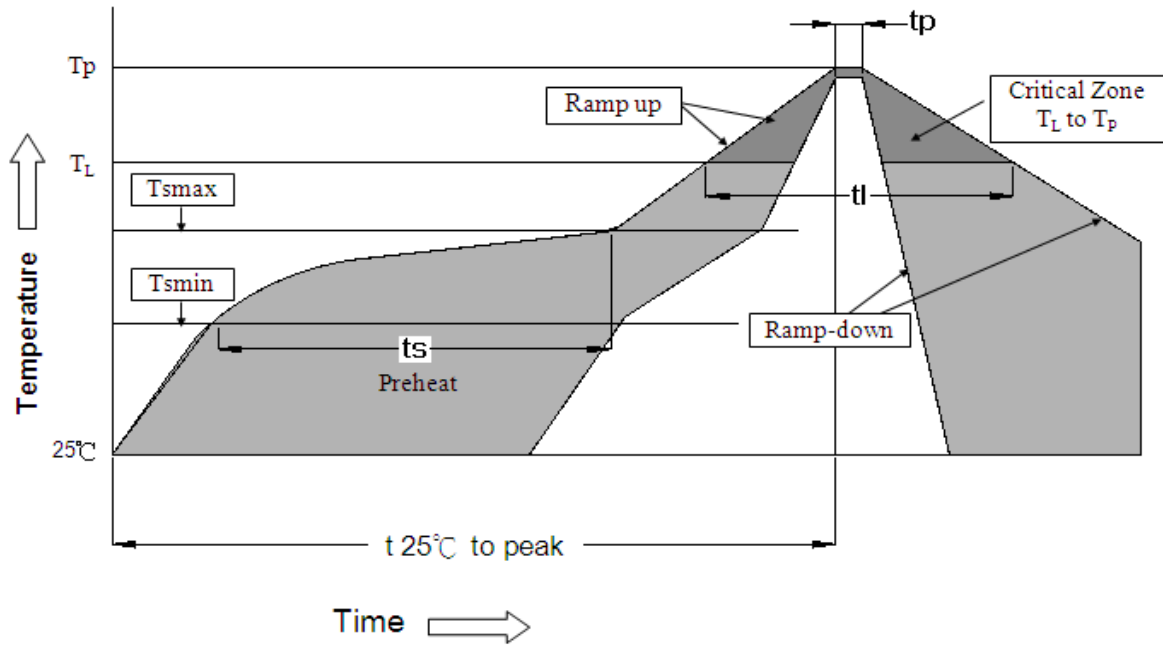

$T_L = 217^\circ\text{C}$

$T_p = 245^\circ\text{C}$

$t_s = 60-120\text{s}$ $T_{s\text{max}} = 200^\circ\text{C}$ $T_{s\text{min}} = 150^\circ\text{C}$

$t_l = 60-150\text{s}$ $t_p = 20-40\text{s}$ $T_{25^\circ\text{C to peak}} = 8\text{min max}$

Ramp up rate = 3°C/s max

Ramp down rate = 6°C/s max

*RoHS Compliant

*Solder Paste SAC 305 Sn 96.5/Ag 3.0/Cu 0.5

*Silkscreen thickness: 0.15mm Min

2. MOISTURE SENSITIVE LEVEL:

2.1. Level: 1

2.2. Shelf Life: Unlimited

2.3. Storage Condition: $\leq 30^\circ\text{C}/85\% \text{RH}$