

July 12, 2022

Description

The **XR33202** is a high performance RS-485/RS-422 transceiver designed to meet the increasing system requirements found in today's portable/handheld, process control and industrial equipment environments. This is a wide supply (3.0V to 5.5V) device that operates at maximum data rate of 20Mbps and features a 1.65V to 5.5V I/O logic supply, simplifying multi-voltage system interfacing requirements.

The receiver includes full fail-safe circuitry, guaranteeing a logic-high receiver output when the receiver inputs are open, shorted or undriven. The XR33202 receiver input impedance is at least 96kΩ (1/8 unit load), allowing more than 256 devices on the bus.

The driver is protected by short circuit detection as well as thermal shutdown and maintains high impedance in shutdown or when powered off. The XR33202 does not have slew limiting and is intended for high speed applications requiring data rates up to 20Mbps.

The DE and \overline{RE} pins include hot swap circuitry to prevent false transitions on the bus during power up or live insertion and can enter a 1μA low current shutdown mode for extreme power savings.

The XR33202 is a half-duplex device that operates at max data rates of 20Mbps. It is available in a 10-pin TDFN package.

FEATURES

- Wide 3.0V to 5.5V supply operation
- 1.65V to 5.5V I/O logic interface VL pin
- Enhanced receiver fail-safe protection for open, shorted or terminated but idle data lines
- Max data rate of 20Mbps
- 1/8 unit load, up to 256 receivers
- Hot swap glitch protection on DE and \overline{RE} Pins
- Robust ESD (Electrostatic Discharge) protection for RS-485 bus pins
 - ±15kV human body model
 - ±15kV IEC61000-4-2 air discharge
 - ±8kV IEC61000-4-2 contact discharge
- Driver short circuit limit and thermal shutdown for overload protection
- -40°C to 125°C ambient operating temperature range
- Lead-free (RoHS 6) TDFN

APPLICATIONS

- Portable and handheld equipment
- Industrial and process control equipment
- Point-of-sale equipment
- Building security and automation

Typical Application

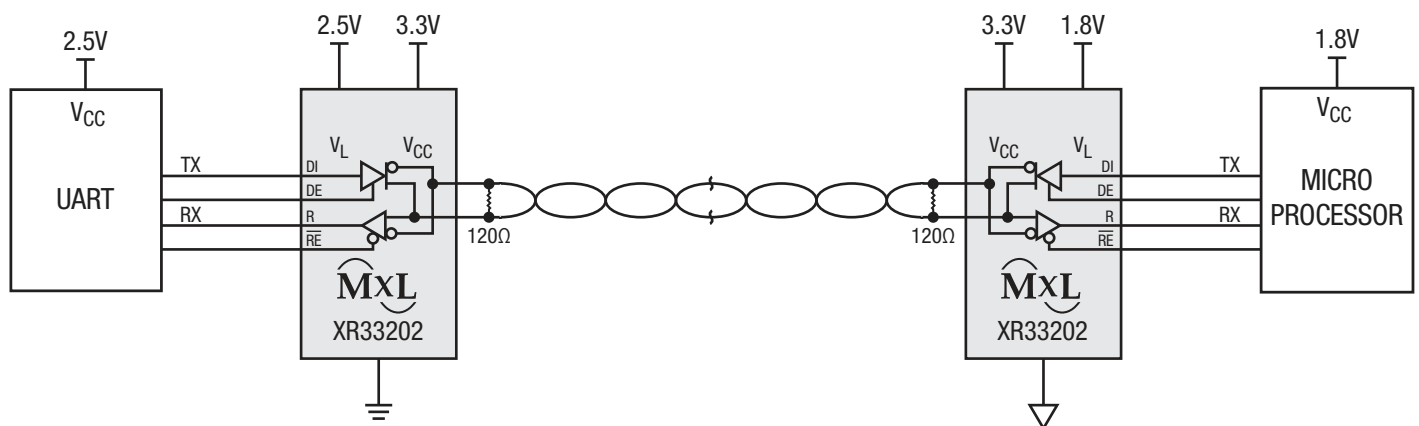

Figure 1. Typical Application

Absolute Maximum Ratings

Stresses beyond those listed under Absolute Maximum Ratings may cause permanent damage to the device. Exposure to any Maximum Rating condition for extended periods may affect device reliability and lifetime.

Supply voltage (V_{CC})	-0.3V to 7.0V
Logic interface voltage (V_L)	$V_L \leq V_{CC}$
Junction temperature	150°C
Input voltage	
DE and DI	-0.3V to 6.0V
\overline{RE}	-0.3V to ($V_L + 0.3V$)
Output voltage	-0.3V to ($V_L + 0.3V$)
Driver output voltage A/Y, B/Z	$\pm 18V$
Receiver input voltage A/Y, B/Z	$\pm 18V$

ESD Ratings

HBM - Human Body Model	
(RS-485 bus pins A/Y, B/Z)	$\pm 15kV$
HBM - Human Body Model (all other pins)	
	$\pm 4kV$
IEC61000-4-2 Air Discharge	
(RS-485 bus pins A/Y, B/Z)	$\pm 15kV$
IEC61000-4-2 Contact Discharge	
(RS-485 bus pins A/Y, B/Z)	$\pm 8kV$

Operating Conditions

Operating temperature range	-40°C to 125°C
V_{CC} supply range	3.0V to 5.5V
V_L I/O supply range ($V_L \leq V_{CC}$)	1.65V to 5.5V

Thermal Information

θ_{JA}	40.5°C/W
θ_{JC}	8.5°C/W

Pin Configuration

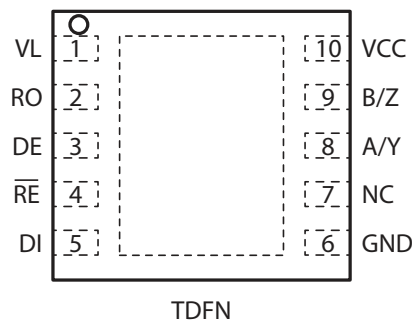

Pin Functions

Pin Number	Pin Name	Type	Description
1	VL	Supply	I/O power supply, sets the logic levels for RO, DE, $\overline{\text{RE}}$ and DI
2	RO	Output	Receiver output
3	DE	Input	Driver enable, driver active when DE = 1, disabled when DE = 0
4	$\overline{\text{RE}}$	Input	Receiver enable, receiver is disabled when $\overline{\text{RE}}$ = 1, enabled when $\overline{\text{RE}}$ = 0
5	DI	Input	Driver input
6	GND	Supply	Ground
7	NC		No connection, can be connected to ground
8	A/Y	I/O	$\pm 15\text{kV}$ ESD protected, RS-485/RS-422 half-duplex non-inverting receiver input and non-inverting driver output
9	B/Z	I/O	$\pm 15\text{kV}$ ESD protected, RS-485/RS-422 half-duplex inverting receiver input and inverting driver output
10	VCC	Supply	Power supply
*	Paddle		Exposed paddle (TDFN package), connect to ground

Transmitting				
Inputs			Outputs	
nRE	DE	DI	A/Y	B/Z
X	1	1	1	0
X	1	0	0	1
0	0	X	High-Z	
1	0	X	Shutdown	

Receiving			
Inputs			Output
nRE	DE	$V_{A/Y} - V_{B/Z}$	RO
0	X	$\geq -50\text{mV}$	1
0	X	$-200\text{mV} < V_{A/Y} - V_{B/Z} < -50\text{mV}$	Undefined
0	X	$\leq -200\text{mV}$	0
0	X	Open/Shorted/Idle	1
1	1	X	High-Z
1	0	X	Shutdown

Electrical Characteristics

Specifications are at $T_A = T_{MIN}$ to T_{MAX} , $V_{CC} = 3.3V \pm 10\%$ or $5.0V \pm 10\%$, $V_L = V_{CC}$ unless otherwise noted. Typical values represent the most likely parametric norm at $T_A = 25^\circ C$, and are provided for reference purposes only.

Symbol	Parameter	Conditions	Min	Typ	Max	Units
Driver DC Characteristics						
V_{OD}	Differential driver output	$R_L = 100\Omega$ (RS-422), $V_{CC} = 3.0V$	2.0			V
		$R_L = 54\Omega$ (RS-485), $V_{CC} = 3.0V$	1.5			V
		$R_L = 100\Omega$ (RS-422), $V_{CC} = 4.5V$	2.25			V
		$R_L = 54\Omega$ (RS-485), $V_{CC} = 4.5V$	2.25			V
ΔV_{OD}	Change in magnitude of differential output voltage	$R_L = 100\Omega$ or 54Ω	-0.2		0.2	V
V_{CM}	Driver common-mode output voltage (steady state)	$R_L = 100\Omega$ or 54Ω		$V_{CC}/2$	3	V
ΔV_{CM}	Change in magnitude of common-mode output voltage	$R_L = 100\Omega$ or 54Ω	-0.2		0.2	V
$I_{A, B}$	Input current (A and B)	$V_{OUT} = 12V$, $DE = 0V$ $V_{CC} = 0V$ or $5.5V$			125	μA
		$V_{OUT} = -7V$, $DE = 0V$ $V_{CC} = 0V$ or $5.5V$	-100			μA
I_{OL}	Output leakage (Y and Z)	$V_{OUT} = 12V$, $DE = 0V$ $V_{CC} = 0V$ or $5.5V$			125	μA
		$V_{OUT} = -7V$, $DE = 0V$ $V_{CC} = 0V$ or $5.5V$	-100			μA
I_{OSD}	Driver short-circuit output current	$-7V \leq V_{OUT} \leq +12V$	-250		250	mA
Receiver DC Characteristics						
V_{TH}	Receiver differential threshold voltage ($V_A - V_B$)	$-7V \leq V_{CM} \leq 12V$	-200	-125	-50	mV
ΔV_{OH}	Receiver input hysteresis	$V_{CM} = 0V$		25		mV
R_{IN}	Receiver input resistance	$-7V \leq V_{CM} \leq 12V$	96			k Ω
I_{OSC}	Receiver output short-circuit current	$0V \leq V_{RO} \leq V_L$	-120		120	mA
Logic Inputs and Outputs						
V_{IH}	Logic input thresholds (DI, DE, \overline{RE}) $1.65V \leq V_L \leq 5.5V$ & $V_L \leq V_{CC}$	Logic input high	$2/3 \cdot V_L$			V
V_{IL}		Logic input low			$1/3 \cdot V_L$	V
V_{HYS}	Input hysteresis (DI, DE, \overline{RE})			50		mV
I_{IN}	Logic input current (DI, DE, \overline{RE})	$0V \leq V_{IN} \leq V_L$, after first transition			1	μA
I_{INHS}	Logic input current hot swap (DE and \overline{RE})	Until first transition			± 320	μA
V_{OH}	Receiver output high voltage (RO)	$3.0V \leq V_L \leq 5.5V$, $I_{OUT} = -1mA$ $1.6V \leq V_L \leq 3.0V$, $I_{OUT} = -1mA$	$V_L - 0.6$			V
V_{OL}	Receiver output low voltage (RO)	$3.0V \leq V_L \leq 5.5V$, $I_{OUT} = 1mA$ $1.6V \leq V_L \leq 3.0V$, $I_{OUT} = 1mA$			0.4	V
I_{OZR}	High-Z receiver output current	$0V \leq V_{OUT} \leq V_L$	-1		1	μA

Electrical Characteristics (Continued)

Specifications are at $T_A = T_{MIN}$ to T_{MAX} , $V_{CC} = 3.3V \pm 10\%$ or $5.0V \pm 10\%$, $V_L = V_{CC}$ unless otherwise noted. Typical values represent the most likely parametric norm at $T_A = 25^\circ C$, and are provided for reference purposes only.

Symbol	Parameter	Conditions	Min	Typ	Max	Units
Supply						
V_{CC}	Supply voltage range		3.0		5.5	V
I_{CC}	Supply current	No load. $\overline{RE} = 0V$, $DE = V_L$, $DI = 0V$		400	600	μA
		No load. $\overline{RE} = V_L$, $DE = V_L$, $DI = 0V$		300	600	μA
		No load. $\overline{RE} = 0V$, $DE = 0V$, receiver A and B inputs open		300	500	μA
I_{SHDN}	Supply current in shutdown mode	$\overline{RE} = V_L$, $DE = 0V$		0.05	3	μA

Driver AC Characteristics

Specifications are at $T_A = T_{MIN}$ to T_{MAX} , $V_{CC} = 3.3V \pm 10\%$ or $5.0V \pm 10\%$, $V_L = V_{CC}$ unless otherwise noted. Typical values represent the most likely parametric norm at $T_A = 25^\circ C$, and are provided for reference purposes only.

Symbol	Parameter	Conditions	Min	Typ	Max	Units
t_{DPLH}	Driver prop. delay (low to high)	$C_L = 50pF$, $R_L = 54\Omega$,			30	ns
t_{DPHL}	Driver prop. delay (high to low)				30	ns
$ t_{DPLH} - t_{DPHL} $	Differential driver output skew				5	ns
t_{DR} , t_{DF}	Driver differential output rise or fall time				17	ns
	Maximum data rate	$1/t_{UI}$, duty cycle 40% to 60%	20			Mbps
t_{DZH}	Driver enable to output high	$C_L = 50pF$, $R_L = 500\Omega$,			50	ns
t_{DZL}	Driver enable to output low				50	ns
t_{DHZ}	Driver disable from output high				50	ns
t_{DLZ}	Driver disable from output low				50	ns
$t_{DZH(SHDN)}$	Driver enable from shutdown to output high	$C_L = 50pF$, $R_L = 500\Omega$,			250	ns
$t_{DZL(SHDN)}$	Driver enable from shutdown to output low				250	ns
t_{SHDN}	Time to shutdown		50	200	600	ns

Electrical Characteristics (Continued)

Receiver AC Characteristics

Specifications are at $T_A = T_{MIN}$ to T_{MAX} , $V_{CC} = 3.3V \pm 10\%$ or $5.0V \pm 10\%$, $V_L = V_{CC}$ unless otherwise noted. Typical values represent the most likely parametric norm at $T_A = 25^\circ C$, and are provided for reference purposes only.

Symbol	Parameter	Conditions	Min	Typ	Max	Units
t_{RPLH}	Receiver prop. delay (low to high)	$C_L = 50pF, R_L = 54\Omega$			50	ns
t_{RPHL}	Receiver prop. delay (high to low)				50	ns
$ t_{RPLH} - t_{RPHL} $	Receiver propagation delay skew				5	ns
	Maximum data rate	$1/t_{UI}$, duty cycle 40% to 60%	20			Mbps
t_{RZH}	Receiver enable to output high	$C_L = 50pF, R_L = 1k\Omega,$			50	ns
t_{RZL}	Receiver enable to output low				50	ns
t_{RHZ}	Receiver disable from output high				50	ns
t_{RLZ}	Receiver disable from output low				50	ns
$t_{RZH(SHDN)}$	Receiver enable from shutdown to output high	$C_L = 50pF, R_L = 1k\Omega,$			2200	ns
$t_{RZL(SHDN)}$	Receiver enable from shutdown to output low				2200	ns
t_{SHDN}	Time to shutdown		50	200	600	ns

Functional Block Diagram

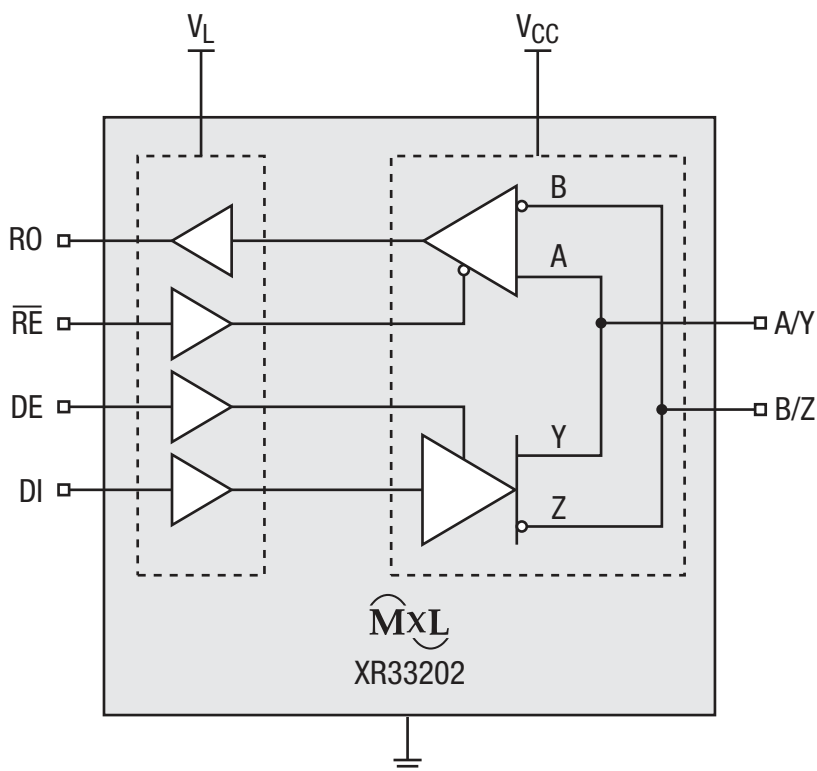

Figure 2. Functional Block Diagram

Applications Information

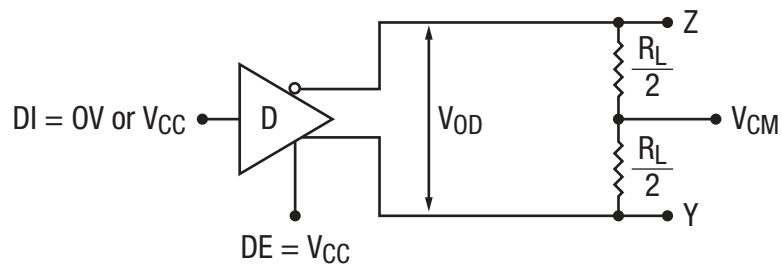

Figure 3. Differential Driver Output Voltage

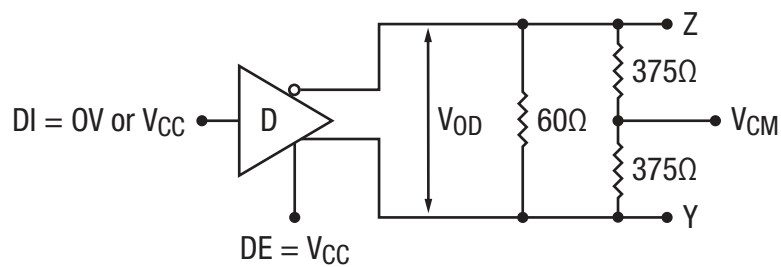

Figure 4. Differential Driver Output Voltage Over Common Mode

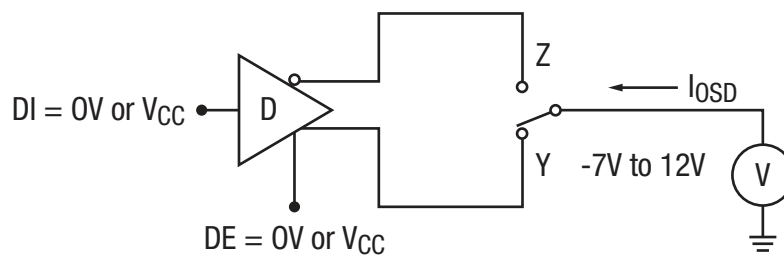

Figure 5. Driver Output Short Circuit Current

Applications Information (Continued)

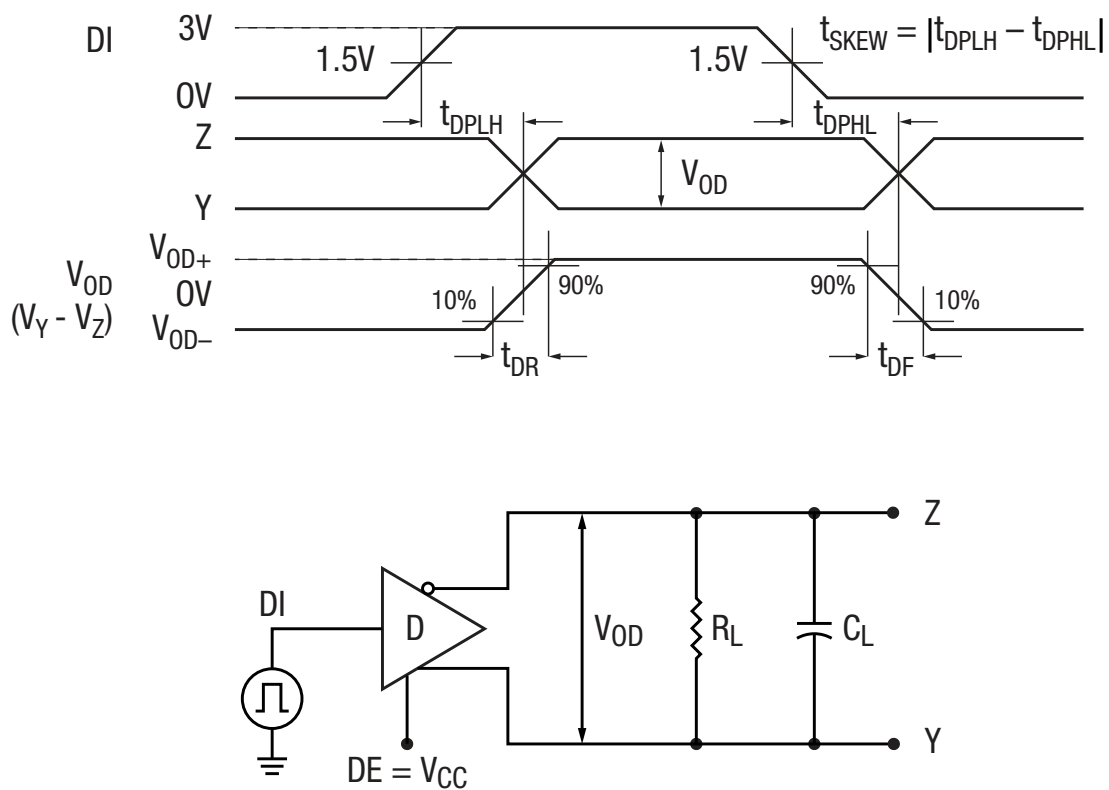

Figure 6. Driver Propagation Delay Test Circuit and Timing Diagram

Applications Information (Continued)

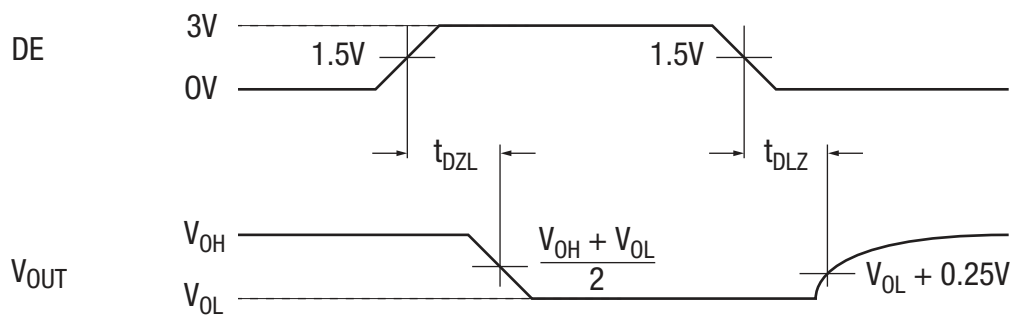
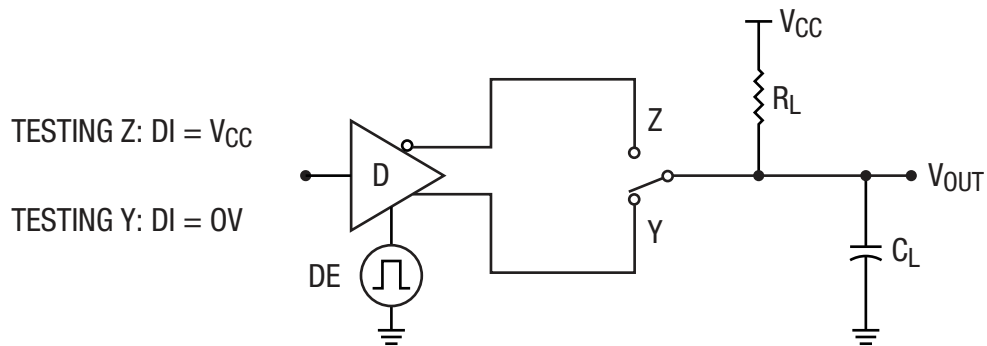
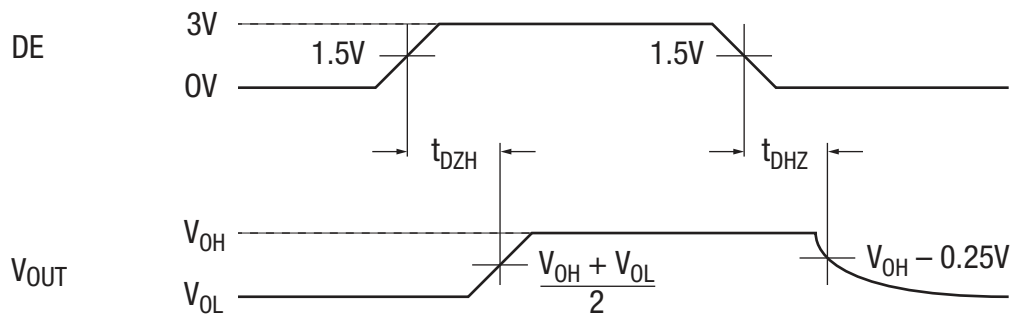
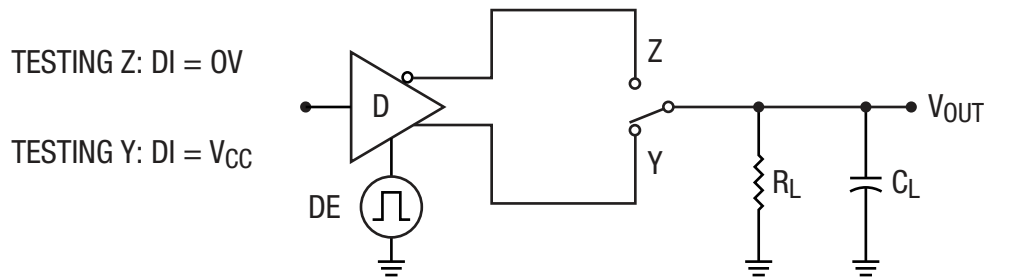

Figure 7. Driver Enable and Disable Timing Test Circuits and Timing Diagrams

Applications Information (Continued)

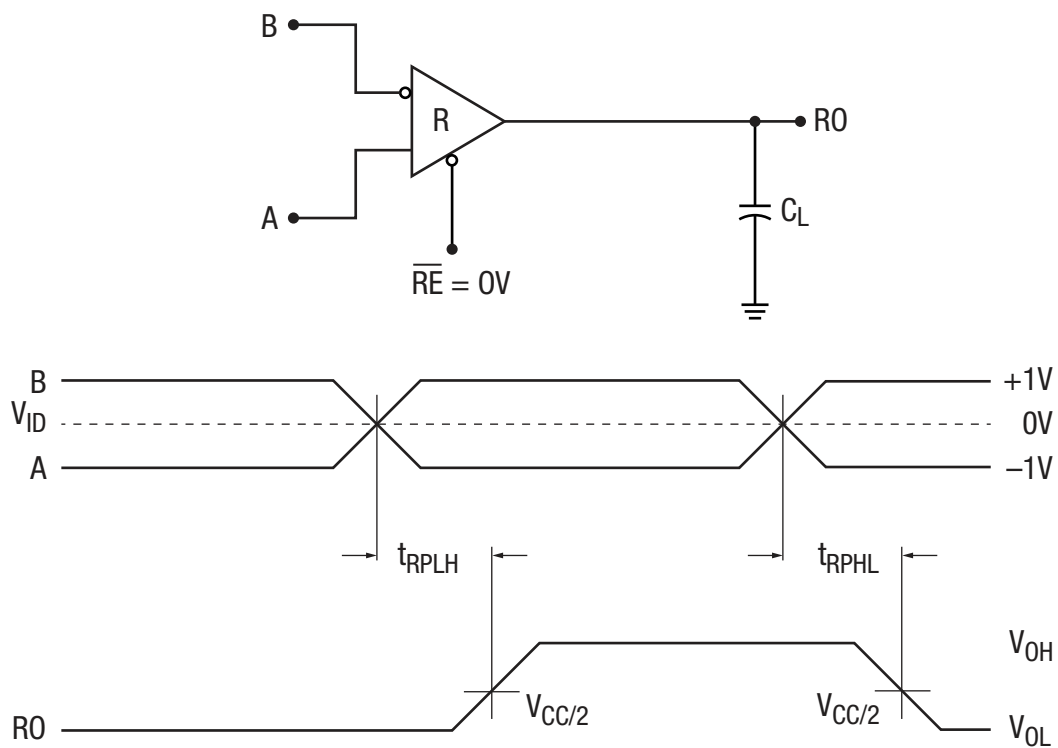

Figure 8. Receiver Propagation Delay Test Circuit and Timing Diagram

Applications Information (Continued)

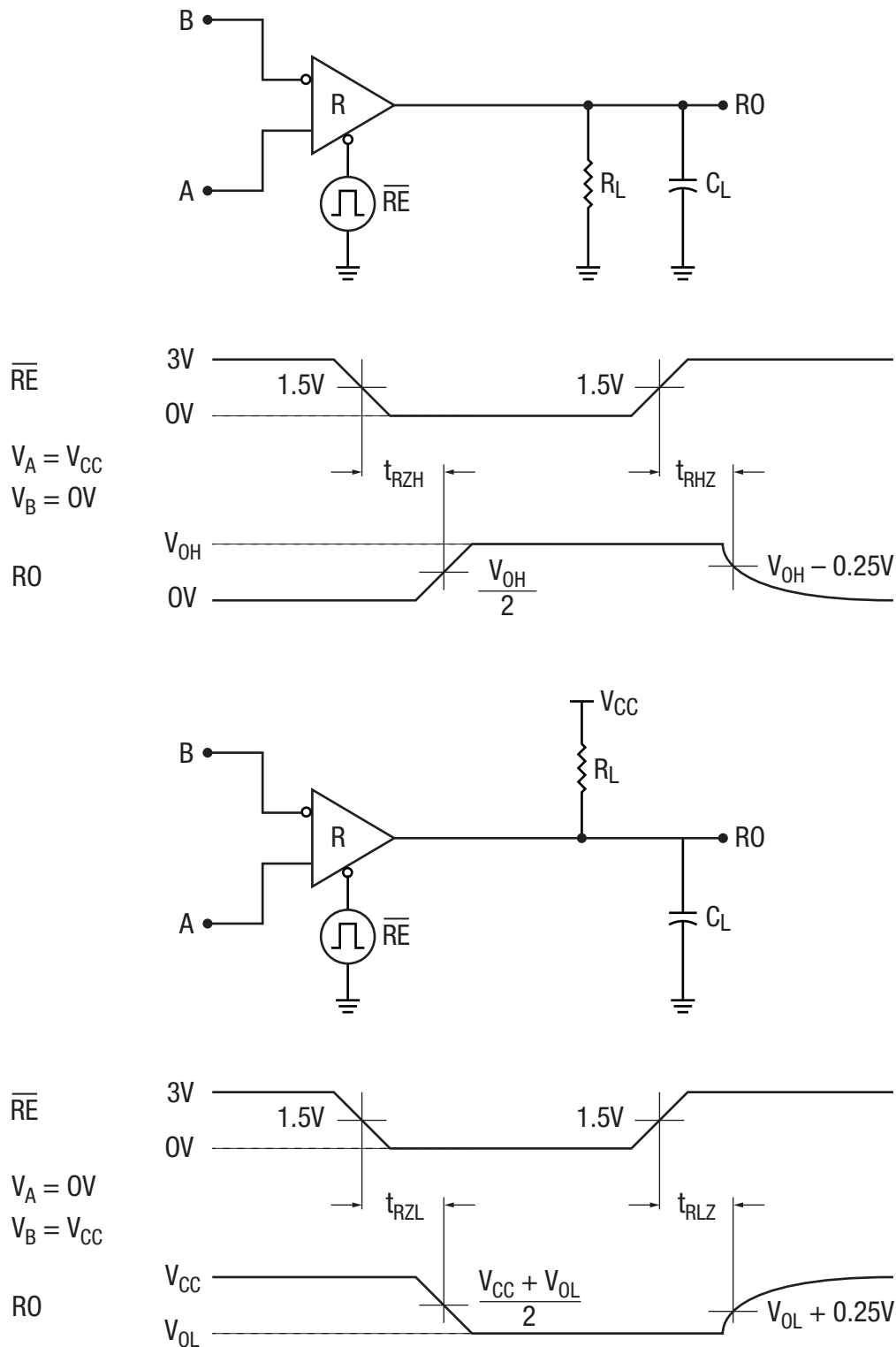

Figure 9. Receiver Enable and Disable Test Circuits and Timing Diagrams

Applications Information (Continued)

The XR33202 RS-485/RS-422 devices are part of MaxLinear's high performance serial interface product line.

Enhanced Failsafe

Ordinary RS-485 differential receivers will be in an indeterminate state whenever the data bus is not being actively driven. The enhanced failsafe feature of the XR33202 guarantees a logic-high receiver output when the receiver inputs are open, shorted or when they are connected to a terminated transmission line with all drivers disabled. In a terminated bus with all transmitters disabled, the receivers' differential input voltage is pulled to 0V by the termination. The XR33202 interprets 0V differential as a logic high with a minimum 50mV noise margin while maintaining compliance with the RS-485 standard of $\pm 200\text{mV}$. Although the XR33202 does not need failsafe biasing resistors, it can operate without issue if biasing is used.

Hot Swap Capability

When V_{CC} is first applied the XR33202 holds the driver enable and receiver enable inactive for approximately $10\mu\text{s}$. During power ramp-up, other system ICs may drive unpredictable values or tristated lines may be influenced by stray capacitance. The hot swap feature prevents the XR33202 from driving any output signal until power has stabilized. After the initial $10\mu\text{s}$, the driver and receiver enable pins are weakly pulled to their disabled states (low for DE and high for RE) until the first transition. After the first transition, the DE and RE pins operate as high impedance inputs.

If circuit boards are inserted into an energized backplane (commonly called "live insertion" or "hot swap") power may suddenly be applied to all circuits. Without the hot swap capability, this situation could improperly enable the transceiver's driver or receiver, driving invalid data onto shared buses and possibly causing driver contention or device damage.

Driver Output Protection

Two mechanisms prevent excessive output current and power dissipation caused by faults or by bus contention. First, a driver current limit on the output stage provides immediate protection against short circuits over the whole common-mode voltage range. Second, a thermal shutdown circuit forces the driver outputs into a high impedance state if junction temperature becomes excessive.

Line Length

The RS-485/RS-422 standard covers cable lengths up to 4000 feet. Maximum achievable line length for a specific application is a function of many factors, the data rate, cable properties, the driver/receiver characteristics and whether or not termination or stubs are used. For lower speed applications, data rates $<150\text{Kbps}$, the maximum cable length is mainly a function of the DC impedance of the cable being used. As data rates increase the capacitive and inductive characteristics tend to dominate and limit the cable lengths that can be achieved. At higher data rates the cable properties will tend to dampen the signal resulting in increased rise/fall times at the far end of the cable.

The XR33202 has been designed with stronger drivers to help compensate for these cable effects and is intended for high speed applications.

$\pm 15\text{kV}$ ESD Protection

ESD protection structures are incorporated on all pins to protect against electrostatic discharges encountered during handling and assembly. The driver outputs and receiver inputs of the XR33202 has extra protection against static electricity. MaxLinear uses state-of-the-art structures to protect these pins against ESD of $\pm 15\text{kV}$ without damage. The ESD structures withstand high ESD in all states: normal operation, shutdown and powered down. After an ESD event, the XR33202 keeps operating without latch up or damage.

ESD protection can be tested in various ways. The transmitter outputs and receiver inputs of the XR33202 is characterized for protection to the following limits:

- $\pm 15\text{kV}$ using the Human Body Model, RS-485 bus pins
- $\pm 4\text{kV}$ using the Human Body Model, all other pins

ESD Test Conditions

ESD performance depends on a variety of conditions. Contact MaxLinear for a reliability report that documents test setup, methodology and results.

Maximum Number of Transceivers on the Bus

The standard RS-485 receiver input impedance is $96\text{k}\Omega$ (1/8 unit load). A standard driver can drive up to 32 unit loads. The XR33202 transceiver has 1/8 unit load receiver input impedance of $96\text{k}\Omega$, allowing up to 256 transceivers to be connected in parallel on a communication line. Any combination of the XR33202 and other RS-485 transceivers up to a total of 32 unit loads may be connected to the bus line.

Applications Information (Continued)

Low Power Shutdown Mode

The XR33202 has a low-power shutdown mode that is initiated by bringing both \overline{RE} high and DE low simultaneously. While in shutdown the XR33202 draws less than 1 μ A of supply current. DE and \overline{RE} may be tied together and driven by a single control signal. Devices are guaranteed not to enter shutdown if \overline{RE} is high and DE is low for less than 50ns. If the inputs are in this state for at least 600ns, the parts will enter shutdown.

XR33202 enable times, t_{DZH} , t_{DZL} , t_{RZH} and t_{RZL} apply when the part is not in low power shutdown state. Enable times, $t_{DZH(SHDN)}$, $t_{DZL(SHDN)}$, $t_{RZH(SHDN)}$ and $t_{RZL(SHDN)}$ apply when the part is shutdown. The driver and receiver take longer to become enabled from low power shutdown than from driver or receiver disable mode.

Product Selector Guide

Part Number	Operation	Data Rate	Shutdown	Receiver/Driver Enable	Nodes On Bus	Footprint
XR33202	Half duplex	20Mbps	Yes	Yes/Yes	80	10-TDFN

Mechanical Dimensions

10-Pin 3mm x 3mm TDFN Package

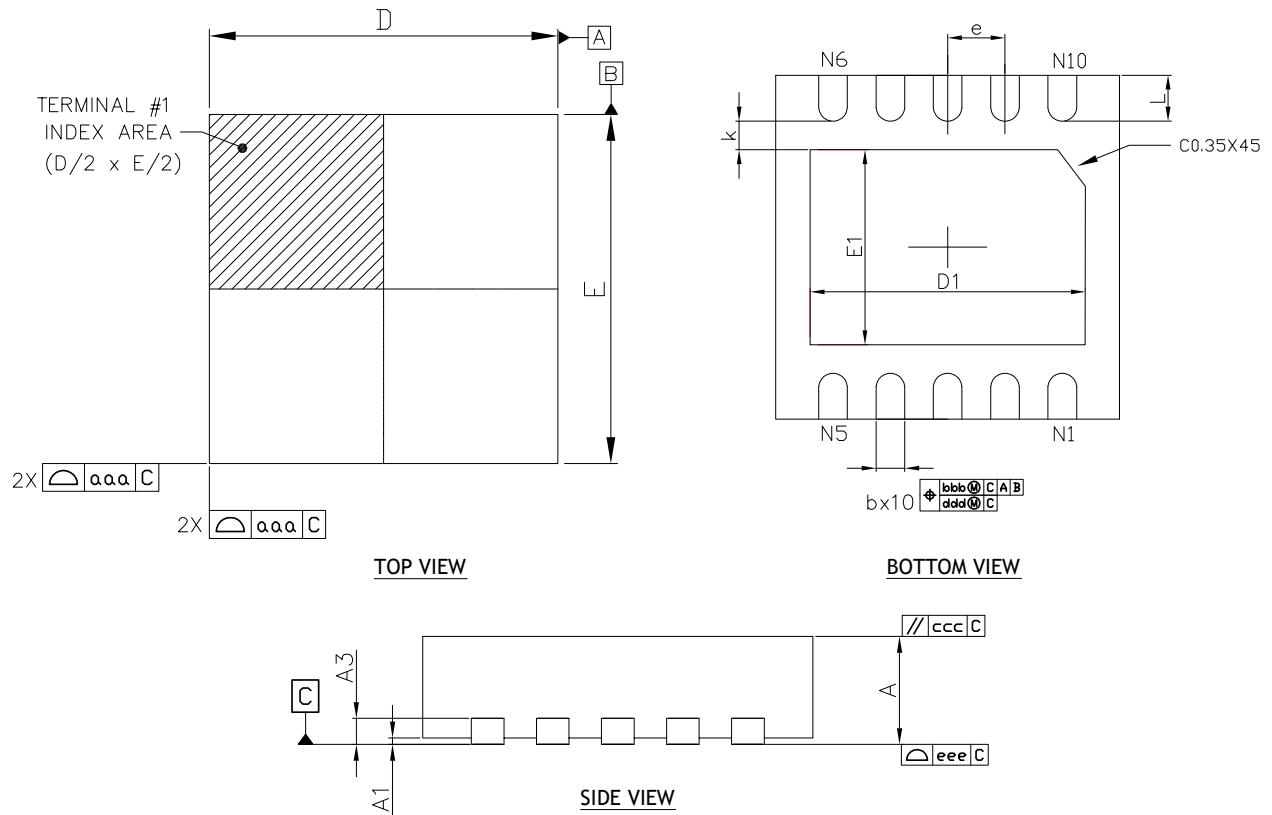

DIM SYMBOL	MIN	NOM	MAX
A	0.70	0.75	0.80
A1	0.00	0.02	0.05
A3	0.203Ref		
b	0.20	0.25	0.30
D	3.00 BSC		
E	3.00 BSC		
e	0.50 BSC		
D1	2.20	2.30	2.40
E1	1.50	1.60	1.70
L	0.30	0.40	0.50
K	0.20	-	-
aaa	0.10		
bbb	0.10		
ccc	0.10		
ddd	0.05		
eee	0.08		
N	10		

TERMINAL DETAILS

- ALL DIMENSIONS ARE IN MILLIMETERS.
- DIMENSIONS AND TOLERANCE PER JEDEC MO-220.

Drawing No.: POD- 00000135

Revision: A

Recommended Land Pattern and Stencil

10-Pin 3mm x 3mm TDFN Package

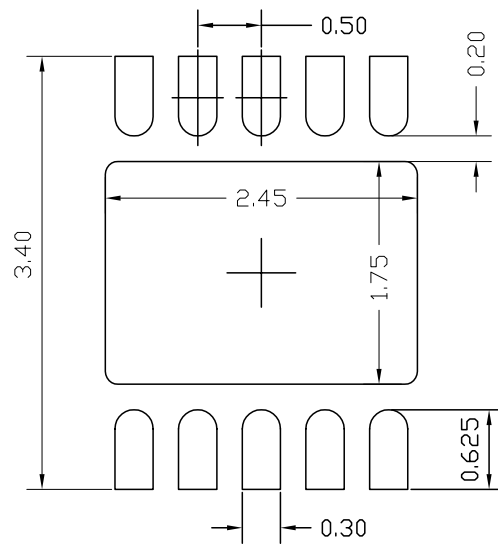

TYPICAL RECOMMENDED LAND PATTERN

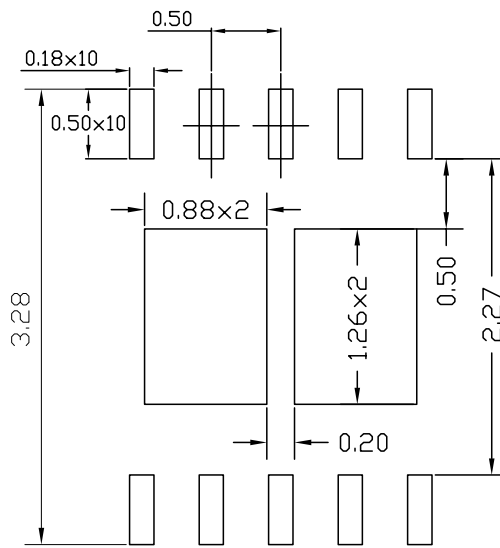

TYPICAL RECOMMENDED STENCIL

Drawing No.: POD- 0000135

Revision: A

Ordering Information⁽¹⁾

Part Number	Operating Temperature Range	Lead-Free	Package	Packaging Method
XR33202EEHBTR-F	-40°C to 125°C	Yes	10-pin TDFN	Tape and Reel
XR33202EEHB-EVB ⁽²⁾	XR33202 Evaluation Board			

NOTE:

- For more information about part numbers, as well as the most up-to-date ordering information and additional information on environmental rating, go to www.maxlinear.com/XR33202.
- XR33202EEHBEVB updated to XR33202EEHB-EVB.

Revision History

Revision	Date	Description
1A	Nov 2015	Initial Release
2A	June 2016	Add Transmitting and Receiving truth tables and Applications Information section. Update Package Quantity in Order Information.
2B	Apr 2018	Update to MaxLinear logo. Update format and Ordering Information. Moved ESD protection / ratings to Absolute Maximum Ratings section.
2C	July 12, 2022	<p>Updated:</p> <ul style="list-style-type: none"> ■ Throughout the document, "DFN" occurrences replaced with "TDFN". ■ In "Electrical Characteristics" section, value of T_A (3 occurrences). <p>Deleted:</p> <ul style="list-style-type: none"> ■ In "Ordering Information" table, XR33202EEHB-F obsolete part number.



Corporate Headquarters:
 5966 La Place Court
 Suite 100
 Carlsbad, CA 92008
 Tel.: +1 (760) 692-0711
 Fax: +1 (760) 444-8598
www.maxlinear.com

The content of this document is furnished for informational use only, is subject to change without notice, and should not be construed as a commitment by MaxLinear, Inc. MaxLinear, Inc. assumes no responsibility or liability for any errors or inaccuracies that may appear in the informational content contained in this guide. Complying with all applicable copyright laws is the responsibility of the user. Without limiting the rights under copyright, no part of this document may be reproduced into, stored in, or introduced into a retrieval system, or transmitted in any form or by any means (electronic, mechanical, photocopying, recording, or otherwise), or for any purpose, without the express written permission of MaxLinear, Inc.

MaxLinear, Inc. does not recommend the use of any of its products in life support applications where the failure or malfunction of the product can reasonably be expected to cause failure of the life support system or to significantly affect its safety or effectiveness. Products are not authorized for use in such applications unless MaxLinear, Inc. receives, in writing, assurances to its satisfaction that: (a) the risk of injury or damage has been minimized; (b) the user assumes all such risks; (c) potential liability of MaxLinear, Inc. is adequately protected under the circumstances.

MaxLinear, Inc. may have patents, patent applications, trademarks, copyrights, or other intellectual property rights covering subject matter in this document. Except as expressly provided in any written license agreement from MaxLinear, Inc., the furnishing of this document does not give you any license to these patents, trademarks, copyrights, or other intellectual property.

MaxLinear, the MaxLinear logo, any MaxLinear trademarks (MxL, Full-Spectrum Capture, FSC, G.now, AirPHY, Puma, and AnyWAN), and the MaxLinear logo on the products sold are all property of MaxLinear, Inc. or one of MaxLinear's subsidiaries in the U.S.A. and other countries. All rights reserved. Other company trademarks and product names appearing herein are the property of their respective owners.

© 2022 MaxLinear, Inc. All rights reserved.