

# ML6427

## 75Ω Quad Video Cable Drivers and Filters with Switchable Inputs

### Features

- Cable drivers for Peritel (SCART), Enhanced Video Connector (EVC), and standard video connectors, 75Ω cable drivers for CV, S-video, and RGB
- 7.1MHz CV, RGB, and S-video, NTSC or PAL filters with mux inputs and output channel mux
- Quad reconstruction filter or dual anti-aliasing filter
- 43dB stopband attenuation at 27MHz
- 1dB flatness up to 4.8MHz
- 12ns group delay flatness up to 10MHz
- 0.4% differential gain, 0.4° differential phase on all channels
- 0.4% total harmonic distortion on all channels
- Master-slave configuration allows up to 8 multiplexed, filtered output signals

### General Description

The ML6427 is a quad 4th-order Butterworth lowpass reconstruction filter plus quad video amplifier optimized for minimum overshoot and flat group delay. Each filter channel has a two-input multiplexer that switches between two groups of quad video signals. Applications driving SCART and EVC cables are supported for composite, component, and RGB video.

1V p-p input signals from DACs are AC coupled into the ML6427 where they are DC restored. Outputs are AC coupled and drive 2Vp-p into a 150Ω load. The ML6427 can provide DC coupled outputs for certain applications.

A fifth unfiltered channel is provided to support an additional analog composite video input. A swapping multiplexer between the two composite channels allows the distribution amplifiers to output from either input.

Several ML6427s can be arranged in a master-slave configuration where an external sync can be used for CV and RGB outputs.

### Block Diagram

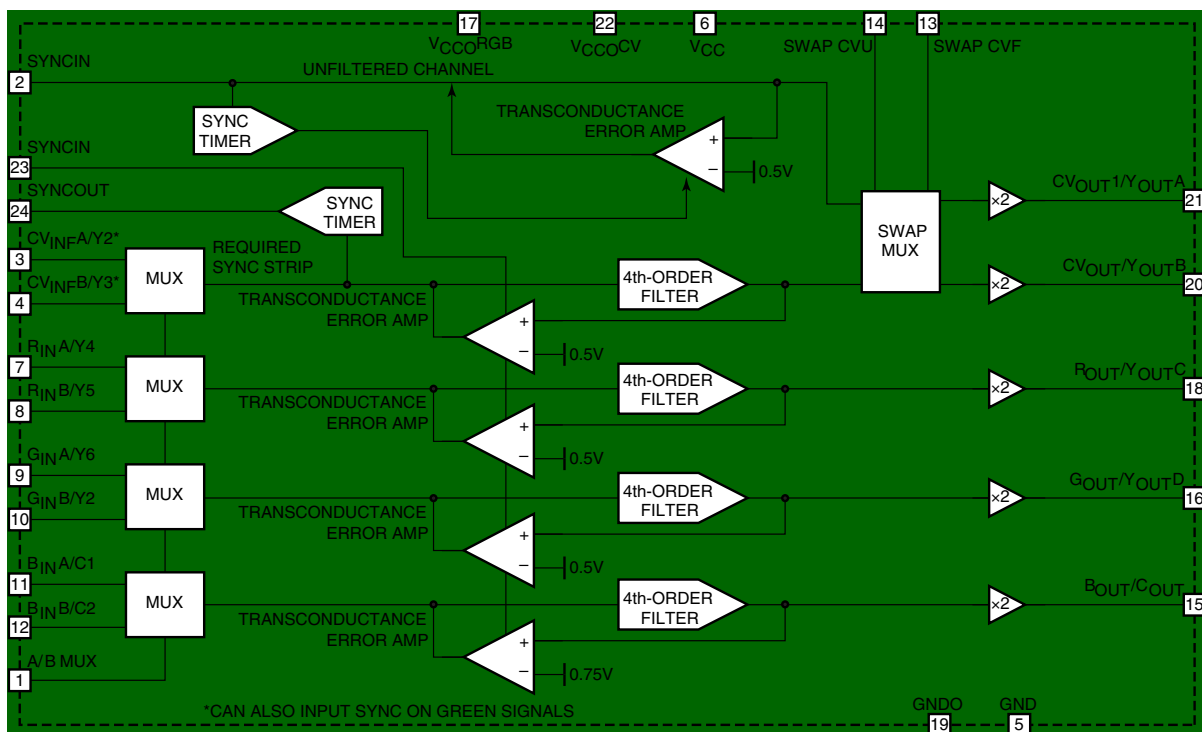

## Pin Configuration

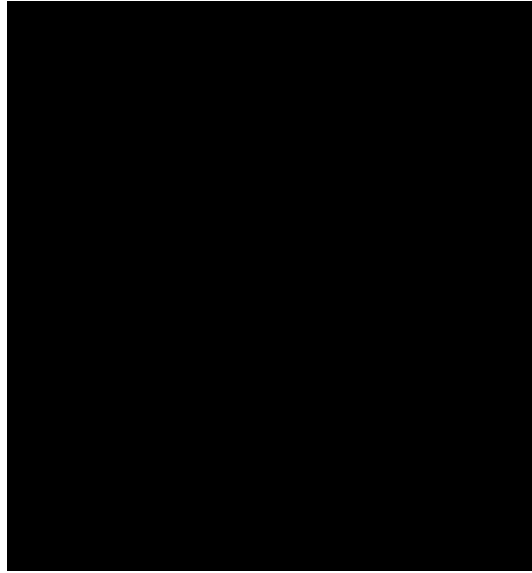

## Pin Description

PIN	NAME	FUNCTION
1	A/B MUX	Logic input pin to select between Bank <A> or <B> of the CV, RGB, or Y/C inputs. Internally pulled high.
2	CVINU/Y1	Unfiltered analog composite video or luma video input. Internally pulled high. A composite or luma or green signal must be present on either the CVINFA/Y2 or the CVINF B/Y3 input to provide necessary sync signals to other channels (R, G, B, Y, C). Otherwise, sync must be provided at SYNCIN. For RGB applications the green channel with sync can be used as an input to this pin (see RGB Applications section).
3	CVINFA/Y2	Filtered analog composite video or luma video input for Bank <A>. Note that SYNC is stripped from this signal for the other channels. A composite or luma or green signal must be present on either the CVINFA/Y2 or the CVINF B/Y3 input to provide necessary sync signals to other channels (R, G, B, Y, C). Otherwise, sync must be provided at SYNCIN. For RGB applications the green channel with sync can be used as an input to this pin (see RGB Applications section).
4	CVINF B/Y3	Filtered analog composite video or luma video input for Bank <B>. Note that SYNC is stripped from this signal for the other channels.
5	GND	Analog ground
6	VCC	Analog 5V supply
7	RINA/Y4	Filtered analog RED video or luma video input for Bank <A>
8	RINB/Y5	Filtered analog RED video or luma video input for Bank <B>
9	GINA/Y6	Filtered analog GREEN video or luma video input for Bank <A>
10	GINB/Y7	Filtered analog GREEN video or luma video input for Bank <B>
11	BINA/C1	Filtered analog BLUE video or chroma video input for Bank <A>
12	BINB/C2	Filtered analog BLUE video or chroma video input for Bank <B>
13	SWAP CVF	Logic input pin to select whether the outputs of CVOUT1/YOUTA and CVOUT2/YOUTB are from filtered or unfiltered CV sources. See Table 1. Internally pulled low.
14	SWAP CVU	Logic input pin to select whether the outputs of CVOUT1/YOUTA and CVOUT2/YOUTB are from filtered or unfiltered CV sources. See Table 1. Internally pulled low.

## Pin Description (continued)

PIN	NAME	FUNCTION
15	BOUT/COUT	Analog BLUE video output or chroma output from either B <sub>IN</sub> A/C1 or B <sub>IN</sub> B/C2
16	GOUT/YOUTD	Analog GREEN video output or luma output from either G <sub>IN</sub> A/Y6 or G <sub>IN</sub> B/Y7
17	VCCORGB	5V power supply for output buffers of the RGB drivers
18	ROUT/YOUTC	Analog RED video output or luma output from either R <sub>IN</sub> A/Y4 or R <sub>IN</sub> B/Y5
19	GNDO	Ground for output buffers
20	CVOUT2/ YOUTB	Composite video output for channel 2 or luma output.
21	CVOUT1/ YOUTA	Composite video output for channel 1 or luma output.
22	VCCOCV	5V power supply for output buffers of the CV drivers.
23	SYNCIN	Input for an external H-sync logic signal for filtered channels. TTL or CMOS. For normal operation SYNCOUT is connected to SYNCIN.
24	SYNCOUT	Logic output for H-sync detect for CV <sub>IN</sub> F A/Y2 or CV <sub>IN</sub> F B/Y3. TTL or CMOS. For normal operation, SYNCOUT is connected to SYNCIN.

## Absolute Maximum Ratings

Absolute maximum ratings are those values beyond which the device could be permanently damaged. Absolute maximum ratings are stress ratings only and functional device operation is not implied.

Parameter	Min.	Max.	Units
VCC		6	V
Junction Temperature		150	°C
ESD		>2000	V
Storage Temperature Range	-65	150	°C
Lead Temperature (Soldering, 10 sec)		260	°C
Thermal Resistance (θ <sub>JA</sub> )		80	°C/W

## Operating Conditions

Parameter	Min.	Max.	Units
Temperature Range	0	70	°C
VDD Range	4.5	5.5	V

## Electrical Characteristics

Unless otherwise specified, VCC = 5V ±10%, TA = Operating Temperature Range (Note 1)

Symbol	Parameter	Conditions	Min.	Typ.	Max.	Units	
I <sub>CC</sub>	Supply Current	No Load (VCC = 5V)		90		mA	
A <sub>V</sub>	Low Frequency Gain (All Channels)	V <sub>IN</sub> = 100mV <sub>P-P</sub> at 300kHz	5.34	6.0	6.65	dB	
V <sub>SYNC</sub>	Channel Sync Output Level CV/Y, R/Y, G/Y Unfiltered	Sync Present and Clamp Settled	0.6	0.9	1.2	V	
		B/C Unfiltered	Sync Present and Clamp Settled	1.2	1.4	1.6	V
		Sync Present and Clamp Settled	0.7	1.0	1.2	V	
t <sub>CLAMP</sub>	Clamp Response Time	Settled to Within 10mV, C <sub>IN</sub> =0.1μF		10		ms	

Symbol	Parameter	Conditions	Min.	Typ.	Max.	Units
$f_{0.5dB}$	0.5dB Bandwidth (Flatness. All Filtered Channels)	All Outputs		4.5		MHz
$f_C$	-3dB Bandwidth (Flatness. All Filtered Channels)	All Outputs (With no Peaking Cap. See Figures 2 and 13)	6.7	7.1		MHz
$0.8f_C$	$0.8 \times f_C$ Attenuation, All Filtered Channels	All Outputs		1.5		dB
$f_{SB}$	Stopband Rejection	All Filtered Channels $f_{IN} = 27\text{MHz}$ to $100\text{MHz}$ worst case (See Figures 2 and 13)	-35	-41		dB
$V_i$	Input Signal Dynamic Range (All Channels)	AC Coupled	1	1.25		VP-P
NOISE	Output Noise (All Channels)	Over a Frequency Band of 25Hz-50MHz		1		mVRMS
OS	Peak Overshoot (All Channels)	2VP-P Output Pulse		4.3		%
ISC	Output Short Circuit Current (All Channels)	Note 2		120		mA
CL	Output Load Capacitance (All Channels)	Load at the Output Pin			35	pF
dG	Differential Gain (All Channels)	All Outputs		0.4		%
d $\Phi$	Differential Phase (All Channels)	All Outputs		0.4		°
THD	Output Distortion (All Channels)	$V_{OUT} = 1.8\text{VP-P}$ at 3.58/4.43MHz		0.4		%
XTALK	Crosstalk  Input A/B MUX Crosstalk Swap Mux Crosstalk	Input of 0.5VP-P at 3.58/4.43MHz on any channel to output of any other channel		-55		dB
		Input of 0.5VP-P at 3.58/4.43MHz		-54		dB
		Input of 0.5VP-P at 3.58/4.43MHz		-52		dB
PSRR	PSRR (All Channels)	0.5VP-P (100kHz) at VCC		-39		dB
$t_{pd}$	Group Delay (All Channels)	at 100kHz		60		ns
$\Delta t_{pd}$	Group Delay Deviation from Flatness  (All Channels)	to 3.58MHz (NTSC)		4		ns
		to 4.43MHz (PAL)		7		ns
		to 10MHz		12		ns
$V_{IH}$	Input Voltage Logic High	A/B MUX, SWAP CVU, SWAP CVF	2.5			V
$V_{IL}$	Input Voltage Logic Low	A/B MUX, SWAP CVU, SWAP CVF			1	V

**Notes**

- Limits are guaranteed by 100% testing, sampling, or correlation with worst case test conditions.
- Sustained short circuit protection limited to 10 seconds.

## Functional Description

The ML6427 is a quad monolithic continuous time analog video filter designed for reconstructing signals from four video D/A sources. The ML6427 is intended for use in AC coupled input and output applications.

The filters approximate a 4th-order Butterworth characteristic with an optimization toward low overshoot and flat group delay. All outputs are capable of driving 2VP-P into AC coupled 150Ω video loads with up to 35pF of load capacitance at the output pin. They are also capable of driving a 75Ω load at 1VP-P.

All channels are clamped during sync to establish the appropriate output voltage swing range. Consequently the input coupling capacitors do not behave according to the conventional RC time constant. Clamping for all channels settles within 10ms of a change in video sources.

Input coupling capacitors of 0.1μF are recommended for all channels. During sync a feedback error amplifier sources/sinks current to restore the DC level. The net result is that the average input current is zero. Any change in the value of the input coupling capacitors will linearly affect the clamp response times.

The RGB channels have no pulldown current sources and are essentially tilt-free. The inputs of the CV channels sink less than 1μA during active video, resulting in a tilt of less than 1mV for 220μF output capacitors. A 1000μF capacitor is recommended for TV applications to minimize tilt in the CV channels.

### Swap Multiplexer Control

Output pins CVOUT1/YOUTA and CVOUT2/YOUTB are each independently selectable among three input sources (CVINU/Y1, CVINFA/Y2, or CVINFB/Y3) depending on the state of digital inputs SWAP CVF, SWAP CVU, and A/B MUX. This allows the two outputs to remain independent and pass straight through, or to remain independent but swapped, or for both outputs to have the same signal sourcing from either CVINU/Y1, CVINFA/Y2, or CVINFB/Y3 (See Table 1). If SWAP CVF is forced to logic low then CVOUT2/YOUTB is sourced from either the CVINFA/Y2 or the CVINFB/Y3 input. If SWAP CVU is logic low then CVOUT1/YOUTA provides video from either the CVINFA/Y2 or the CVINFB/Y3 input. If SWAP CVF is logic high then CVOUT2/YOUTB provides video from the CVINU/Y1 input. If SWAP CVU is high then CVOUT1/YOUTA provides video from either the CVINFA/Y2 or the CVINFB/Y3 input. Both SWAP CVF and SWAP CVU will pull low if they are not driven.

The ML6427 is robust and stable under all stated load and input conditions. Bypassing both VCC pins directly to ground ensures this performance. Two ML6427s can be connected in a master-slave sync configuration. When using this configuration (See Figure 6) only the “master” ML6427 is required to have a signal with embedded sync present on

the CVINFA/Y2 and CVINFB/Y3 inputs. In the absence of sync on the CVINFA/Y2 and CVINFB/Y3 inputs of the “slave” ML6427 it will have its SYNCIN input connected to the SYNCOUT output of the “master” ML6427.

### SYNCIN and SYNCOUT Pins

Each ML6427 has two sync detectors which control the DC restore functions. The unfiltered channel has its own detector, which controls the DC restore function during the horizontal sync period of the CVINU/Y1 input. The other sync detector controls the DC restore functions for the filtered channels based upon the composite or luma signal at the CVINFA/Y2 or CVINFB/Y3 input.

**Required Setup:** A composite or luma or green signal must be present on CVINFA/Y2 or CVINFB/Y3 inputs to provide necessary sync signals to other channels (R, G, B, Y, C). Otherwise, sync must be provided at the SYNCIN pin. For RGB applications the green channel with sync can be used as an input to CVINFA/Y2 or CVINFB/Y3.

The SYNCOUT pin provides a logic high when it detects the horizontal sync of either the CVINFA/Y2 or CVINFB/Y3 input (note that one input is selected by the A/B MUX pin). The SYNCIN pin is an input for an external H-sync logic signal to enable or disable the internal DC restore loop for the filtered channels. When SYNCIN is logic high the DC restore function is enabled.

For normal operation the SYNCOUT pin is connected to the SYNCIN pin (see Figure 4). If neither the CVINFA/Y2 nor the CVINFB/Y3 has an embedded sync an external sync can be applied on the SYNCIN pin. In master-slave configurations the SYNCOUT of a ML6427 master can be used as the SYNCIN of a ML6427 slave (see Figure 6).

### Video I/O Description

Each input is driven by either a low impedance source or the output of a 75Ω terminated line. The input is required to be AC coupled via a 0.1μF coupling capacitor which gives a nominal clamping time of 10ms. All outputs are capable of driving an AC coupled 150Ω load at 2VP-P or 1VP-P into a 75Ω load. At the output pin, up to 35pF of load capacitance can be driven without stability or slew issues. A 220μF AC coupling capacitor is recommended at the output to reduce power consumption. For DC coupled outputs see the Typical Applications section.

### Analog Multiplexer Control

The four filter channels each have two input multiplexers which are paired to select between two four-channel video sources (i.e., composite video plus RGB component video). If A/B MUX is forced to logic high, it will select Bank<A> of the video inputs (CVINFA/Y2, RINA/Y4, GINA/Y6, BINA/C1) to be enabled. If A/B MUX is logic low then Bank<B> of video inputs (CVINFB/Y3, RINB/Y5, GINB/Y7, BINB/C2) will be selected. If the A/B MUX is open it will pull to logic high.

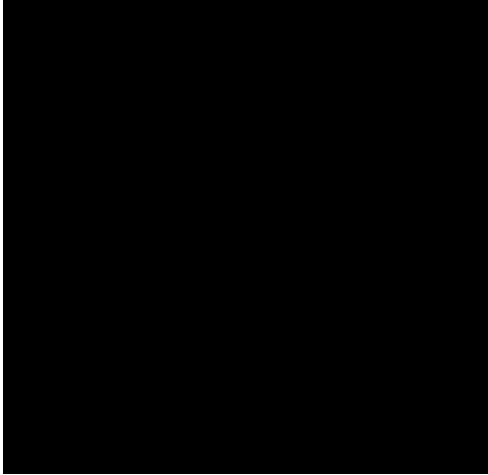

Figure 1. Passband Flatness (Normalized) All outputs. Passband is ripple-free.

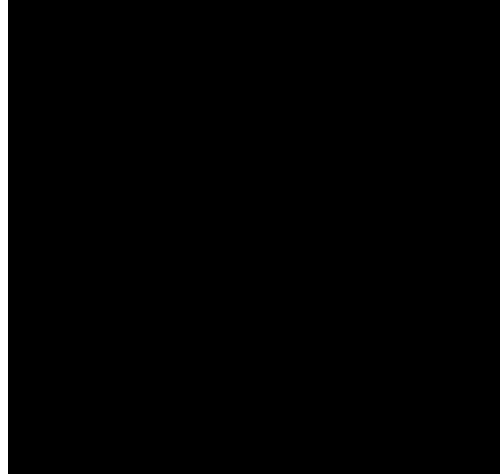

Figure 2. Passband/Stopband Rejection Ratios (Normalized) All outputs.

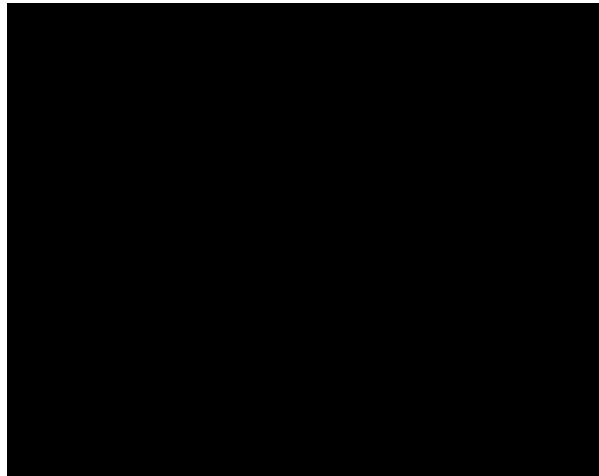

Figure 3. Group Delay, all Outputs Low frequency group delay is 62ns. At 3.58MHz group delay increases by only 4ns. At 4.43MHz group delay increases by only 7ns. The maximum deviation from flat group delay of 12ns occurs at 6MHz.

Table 1. Selecting Composite, Luma, RGB, and Chroma Output

Inputs			Outputs				
A/B MUX	Swap CVU	Swap CVF	CVOUT1/ YOUTA	CVOUT2/ YOUTB	ROUT/YOUTC	GOUT/YOUTD	BOUT/COU
0	0	0	CVINU/Y1	CVINF/Y3	RINB/Y5	GINB/Y7	BINB/C2
0	0	1	CVINU/Y1	CVINU/Y1	RINB/Y5	GINB/Y7	BINB/C2
0	1	0	CVINF/Y3	CVINF/Y3	RINB/Y5	GINB/Y7	BINB/C2
0	1	1	CVINF/Y3	CVINU/Y1	RINB/Y5	GINB/Y7	BINB/C2
1	0	0	CVINU/Y1	CVINF/Y2	RINA/Y4	GINA/Y6	BINA/C1
1	0	1	CVINU/Y1	CVINU/Y1	RINA/Y4	GINA/Y6	BINA/C1
1	1	0	CVINF/Y2	CVINF/Y2	RINA/Y4	GINA/Y6	BINA/C1
1	1	1	CVINF/Y2	CVINU/Y1	RINA/Y4	GINA/Y6	BINA/C1

## Typical Applications

### Basic Applications

The ML6427 provides channels for two banks of inputs for RGB and composite video. The R and G channels can be used as luma inputs while the B channel can be used as a chroma input. Composite outputs and an H-sync output are also provided. There are several configurations available with the ML6427. Figure 4 includes a list of basic output options for composite, S-video, TV modulator, and RGB outputs. Note that each composite channel can drive a CV load and a channel modulator simultaneously. The ML6427 standalone can be used as an EVC or SCART cable driver with nine video sources ( $75\Omega$  or low impedance buffer) and seven video outputs. All inputs and outputs are AC coupled. When driving seven loads the power dissipation must be calculated to ensure that the junction temperature doesn't exceed  $120^{\circ}\text{C}$ .

### EVC Cable Driving

The ML6427 can be configured to drive composite video, S-video, and horizontal sync through an EVC connector (Figure 5). Composite video and S-video inputs are filtered through 4th-order Butterworth filters and driven through internal  $75\Omega$  cable drivers. A buffered H-sync output is also available.

### SCART Cable Driving

The ML6427 can be configured either as a SCART cable driver (Figure 4) or as a SCART cable driver and S-video driver (Figure 6). A horizontal sync output is also available. Note that the ML6427 can be used in a master-slave mode where the SYNCOUT signal from the master is used as the SYNCIN signal of the slave. This allows the CV, S-video, and RGB channels to operate under the same sync signals.

Note that in SCART applications it is not always necessary to AC couple the outputs. Systems using SCART connectors for RGB and composite video can typically handle between 0 and 2VDC offset (see DC Coupled Applications section).

### RGB Applications

RGB video can be filtered and driven through the ML6427 in one of two ways:

1. For sync suppressed RGB the sync signal can be derived from the composite or luma signal on the inputs of CVINFA/Y2 or CVINFB/Y3.
2. For RGB with sync on the green signal the green channel must be fed into either the CVINFA/Y2 or CVINFB/Y3 input. The sync will be extracted from green and used on red and blue channels. See also the SYNCIN and SYNCOUT Sections.

### OSD (On-Screen Display) Applications

Unfiltered RGB video from an OSD processor needs to be filtered and then synchronized to a fast blanking interval or alpha-key signal for later video processing. With the total filter delay being  $80\text{ns} \pm 10\text{ns}$  a D flip-flop or similar delay element can be used to delay the fast blanking interval or alpha-key signal. This will synchronize the RGB and OSD signals (Figure 9).

### CCIR656 and CCIR601 Applications

Composite or luma channels can be fed back into an alternate channel or into another ML6427 (master-slave configuration) so that approximately 80dB/decade attenuation outputs are provided. The ML6427 can be configured for composite and luma loopback (Figure 7). H-sync outputs are also provided.

### Channel Multiplexing

The ML6427 can be configured for multiple composite channel multiplexing (Figure 8). Composite sources such as VCRs, video game consoles, and camcorders can be selected using the ML6427 swap mux controls. A/B MUX, SWAP CVU, and SWAP CVF signals can be used to select and route from various input sources.

### DC COUPLED APPLICATIONS

A  $220\mu\text{F}$  capacitor coupled with a  $150\Omega$  termination resistor forms a highpass filter which blocks DC while passing the video frequencies and avoiding tilt. Lower value capacitors, such as  $10\mu\text{F}$ , would create a problem. By AC coupling the average DC level is zero. Consequently the output voltages of all channels will be centered around zero.

Alternately, DC coupling the output of the ML6427 is allowable. There are several tradeoffs: The average DC level on the outputs will be 2V; Each output will dissipate an additional 40mW nominally; The application will need to accommodate a 1VDC offset sync tip; and it is recommended to use only one  $75\Omega$  load per output. However, if it is necessary to drive two loads at a time on the composite output while DC coupling is used then the swap-mux and 5th line driver can be configured to enable the filtered composite signal on both the 4th and 5th line drivers. This divides the composite load driving requirement into two line drivers versus one.

**Required Setup:** A composite or luma or green signal must be present on the CVINFA/Y2 or the CVINFB/Y3 input to provide necessary sync signals to the other channels (R, G, B, Y, C). Otherwise, sync must be provided at the SYNCIN pin. For RGB applications, the green channel with sync can be used as an input to CVINFA/Y2 or CVINFB/Y3.

### Using the ML6427 for PAL Applications

The ML6427 can be optimized for PAL video by adding frequency peaking to the composite and S-video outputs. Figure 10 illustrates the use of an additional external capacitor (330pF) in parallel with the output source termination resistor. This raises the frequency response from 1.6dB at 4.8MHz to 0.35dB at 4.8MHz, which allows for accurate reproduction of the upper sideband of the PAL subcarrier. Figure 11 shows the frequency response of PAL video with various values of peaking capacitors (220pF, 270pF, 330pF and none) between 0 and 10MHz.

For NTSC applications without the peaking capacitor the rejection at 27MHz is 42dB (typical). For PAL applications with the peaking capacitor the rejection at 27MHz is 38dB (typical). See Figure 12. The differential group delay, shown in Figure 13 with and without a peaking capacitor (220pF, 270pF, and 330pF and none), varies slightly with capacitance from 8ns to 13ns.



Figure 4. Basic Application for NTSC

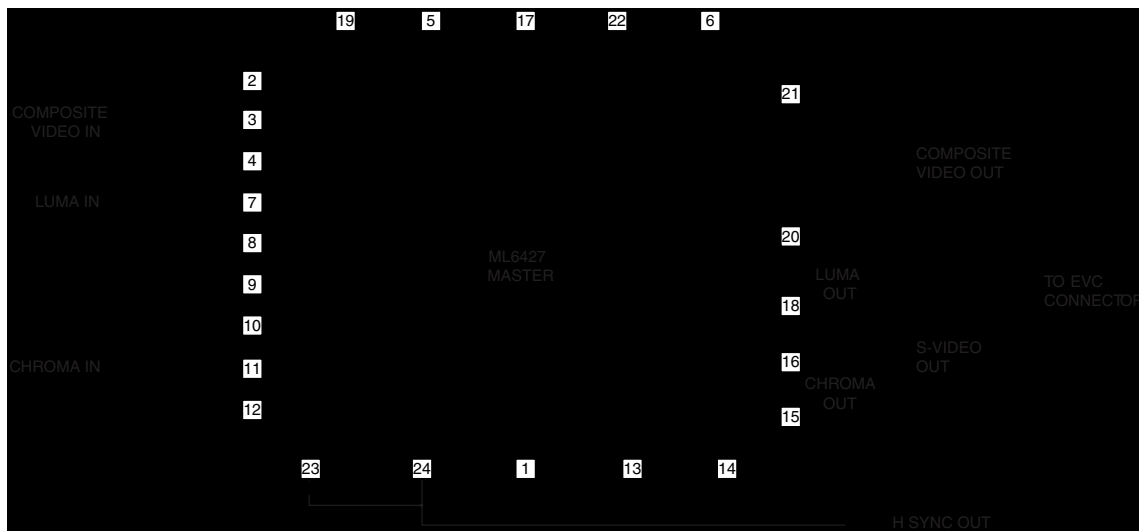

Figure 5. EVC (Enhanced Video Connector) Application: S-Video, Composite, plus H-Sync out



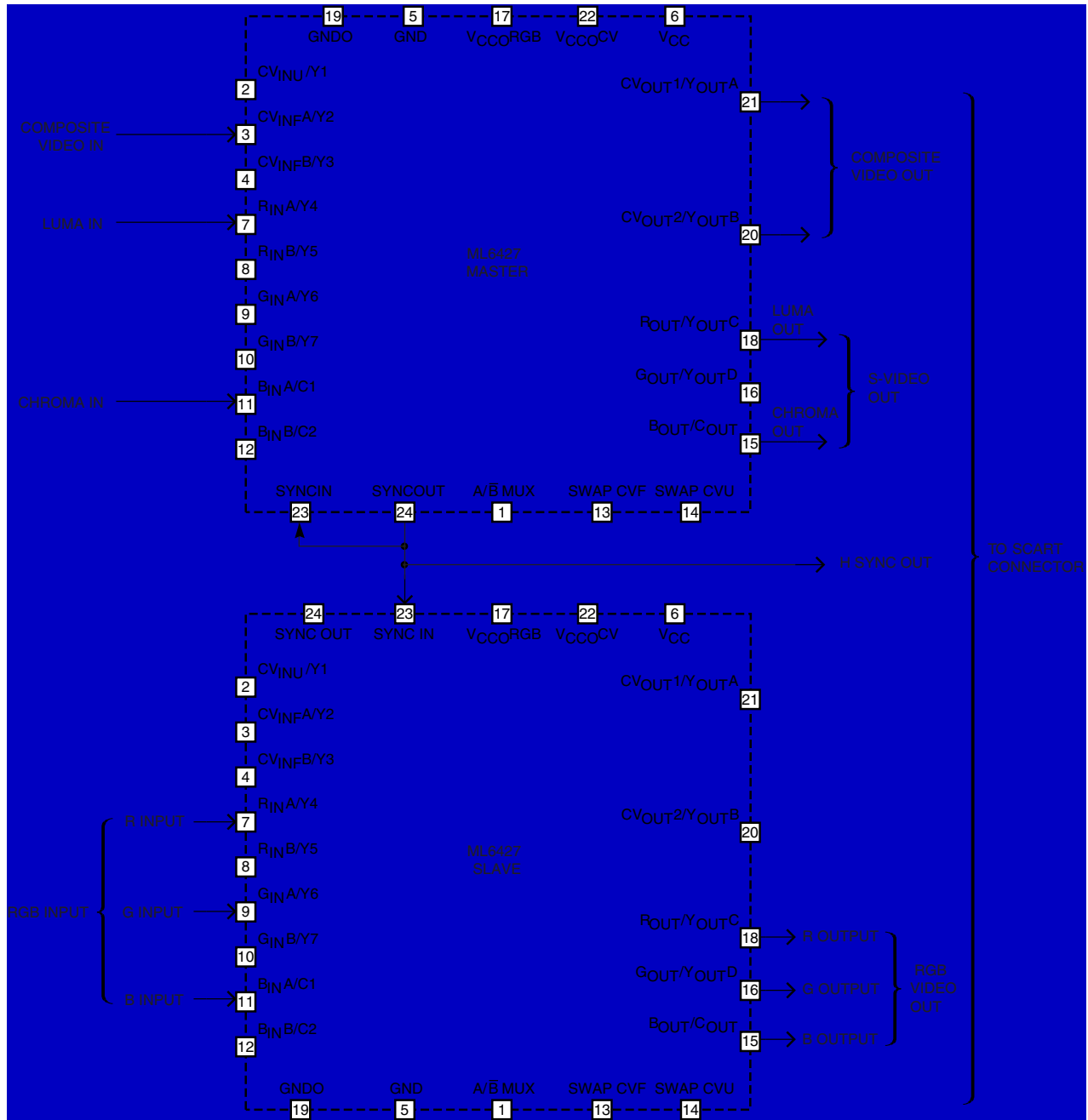

Figure 6. SCART (Peritel) + S-Video Application: S-Video, RGB, Composite, plus H-Sync out

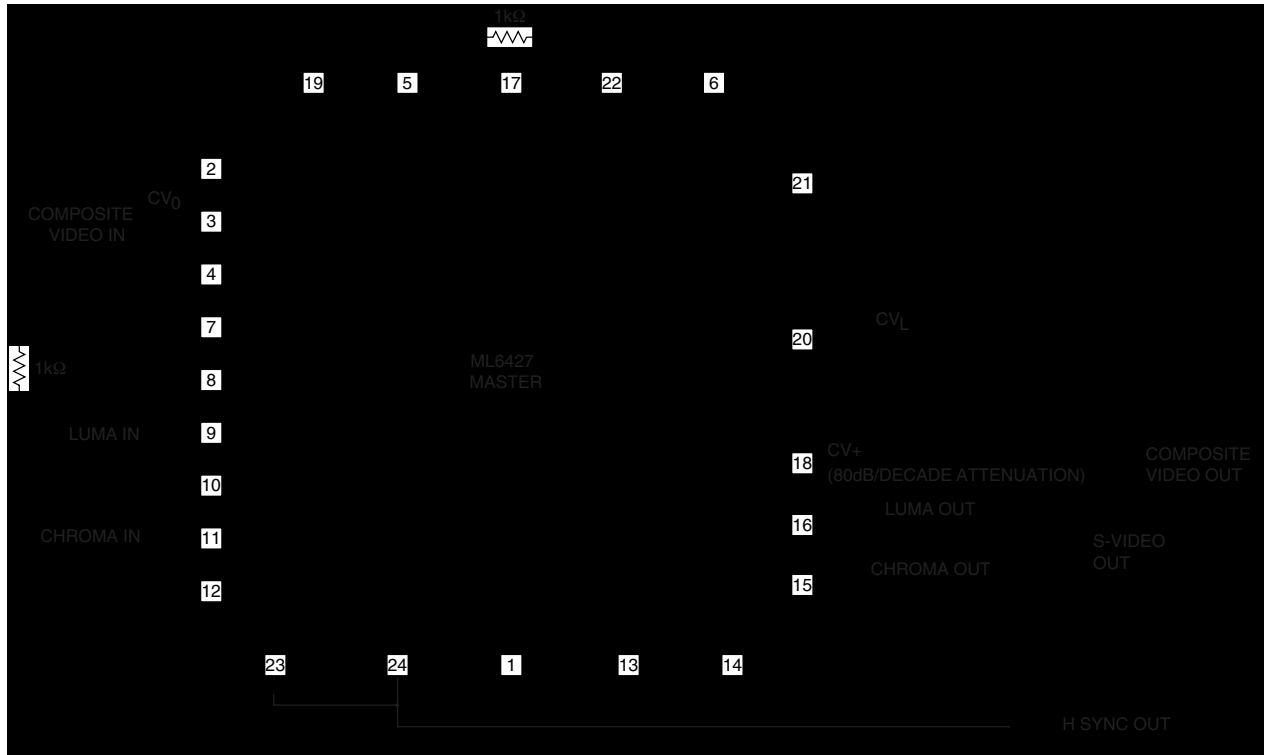

Figure 7a. Composite Loopback (Cascaded Filters) for Additional Attenuation

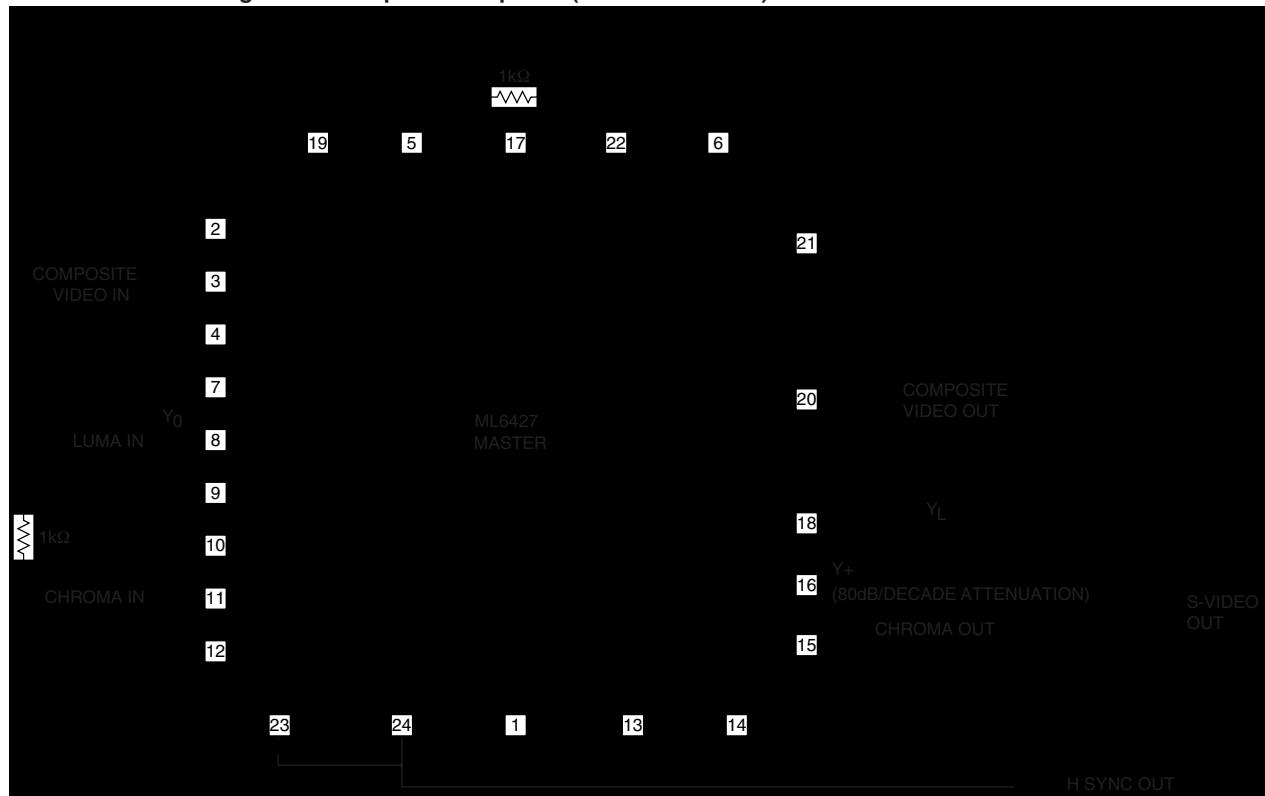

Figure 7b. Luma Loopback (Cascaded Filters) for Additional Attenuation

Figure 7. CCIR656 and CCIR601 Application: Composite and Luma Loopback, plus H-S out.

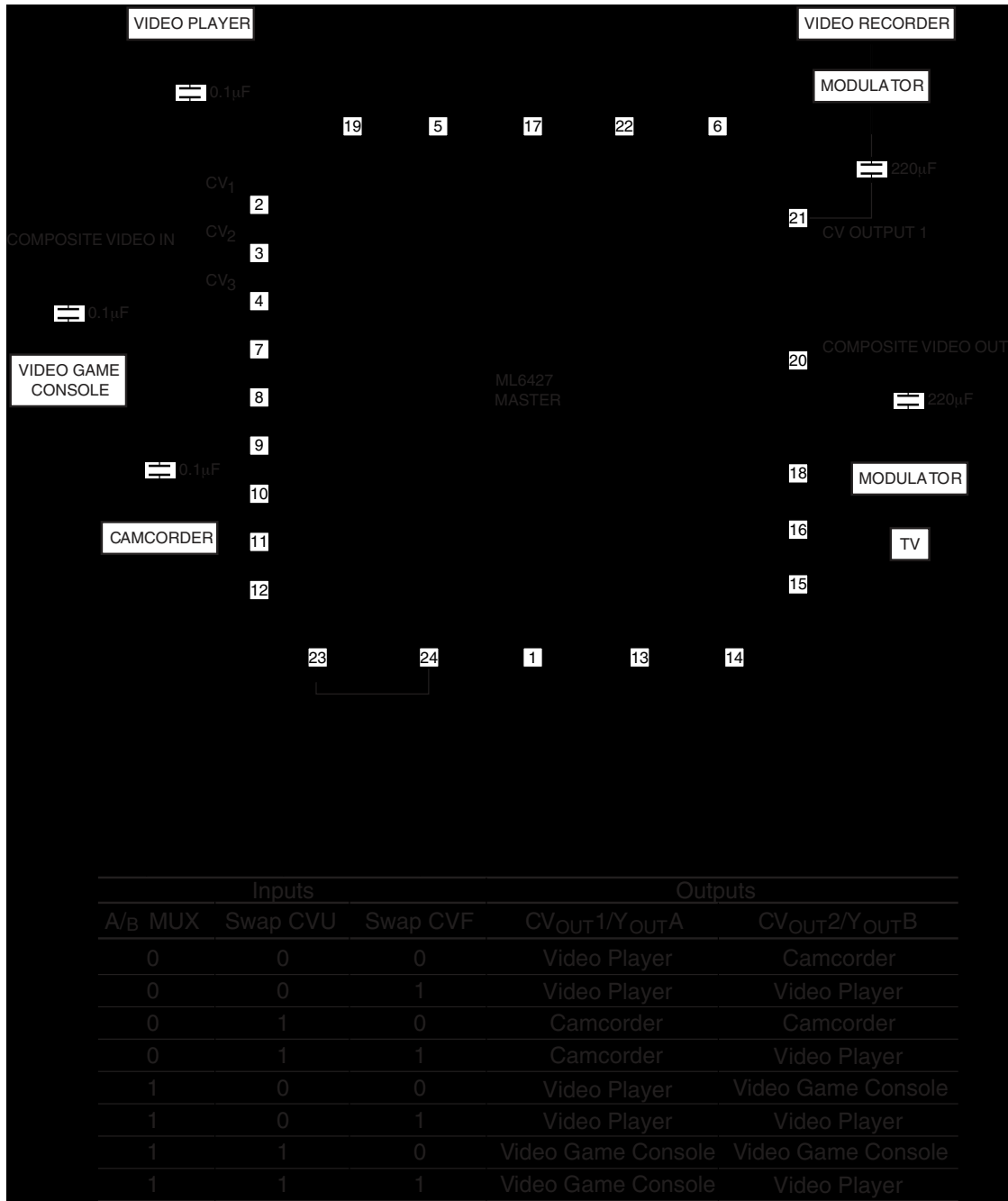

Figure 8. Composite Channel Swapping Application: Multiple Composite Channel Multiplexing

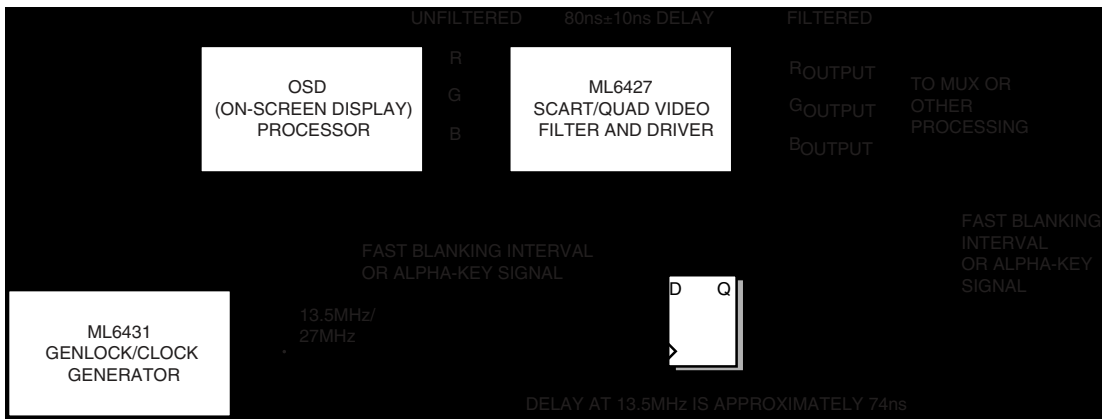

Figure 9. Synchronizing the Filter Delay with Fast Blanking or Alpha-Key Signals in OSD Applications

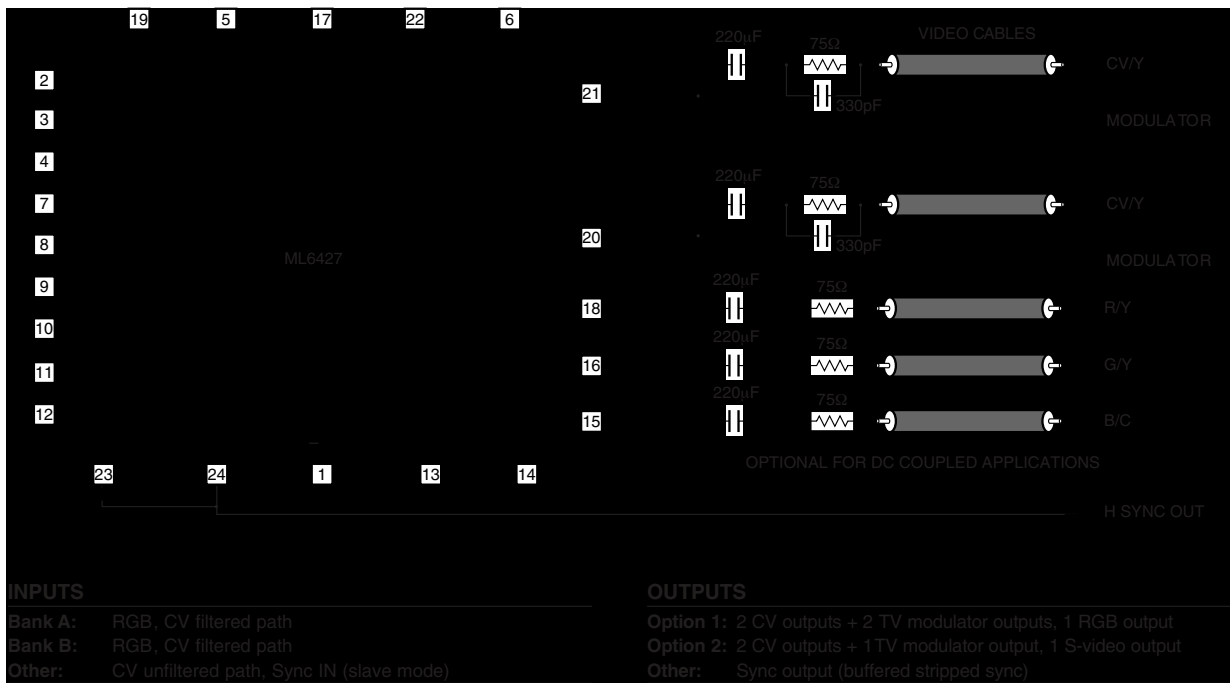

Figure 10. Basic Application for PAL

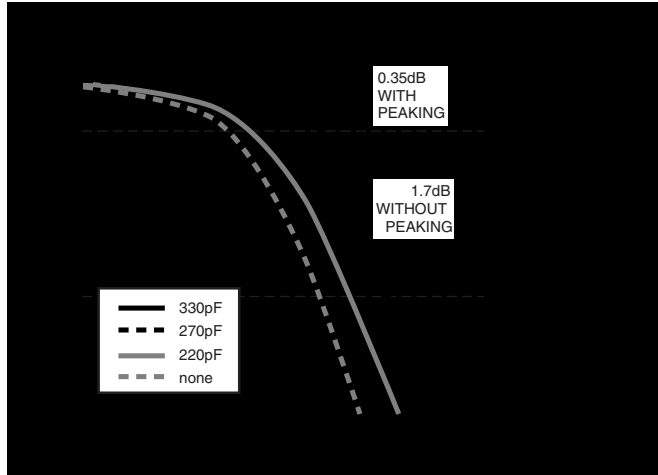

Figure 11. NTSC/PAL Video Frequency Response With and Without Peaking Capacitor

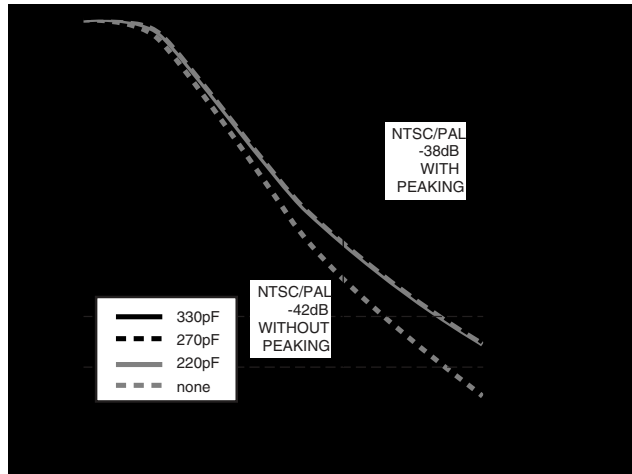

Figure 12. Stopband Rejection at 27MHz With and Without Peaking Capacitor

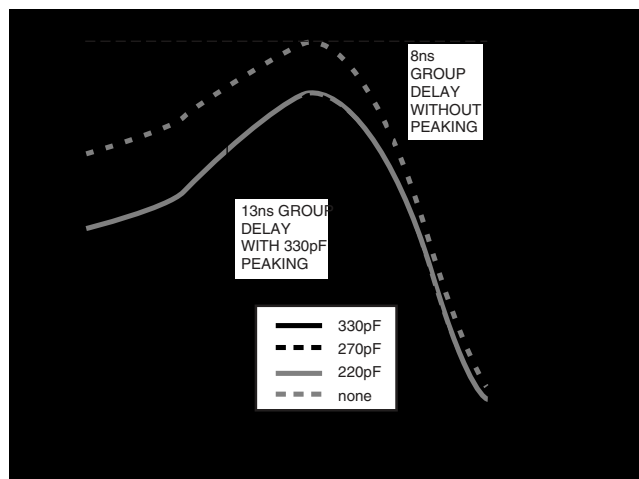

Figure 13. Group Delay at 5.5MHz (PAL) With and Without Peaking Capacitor

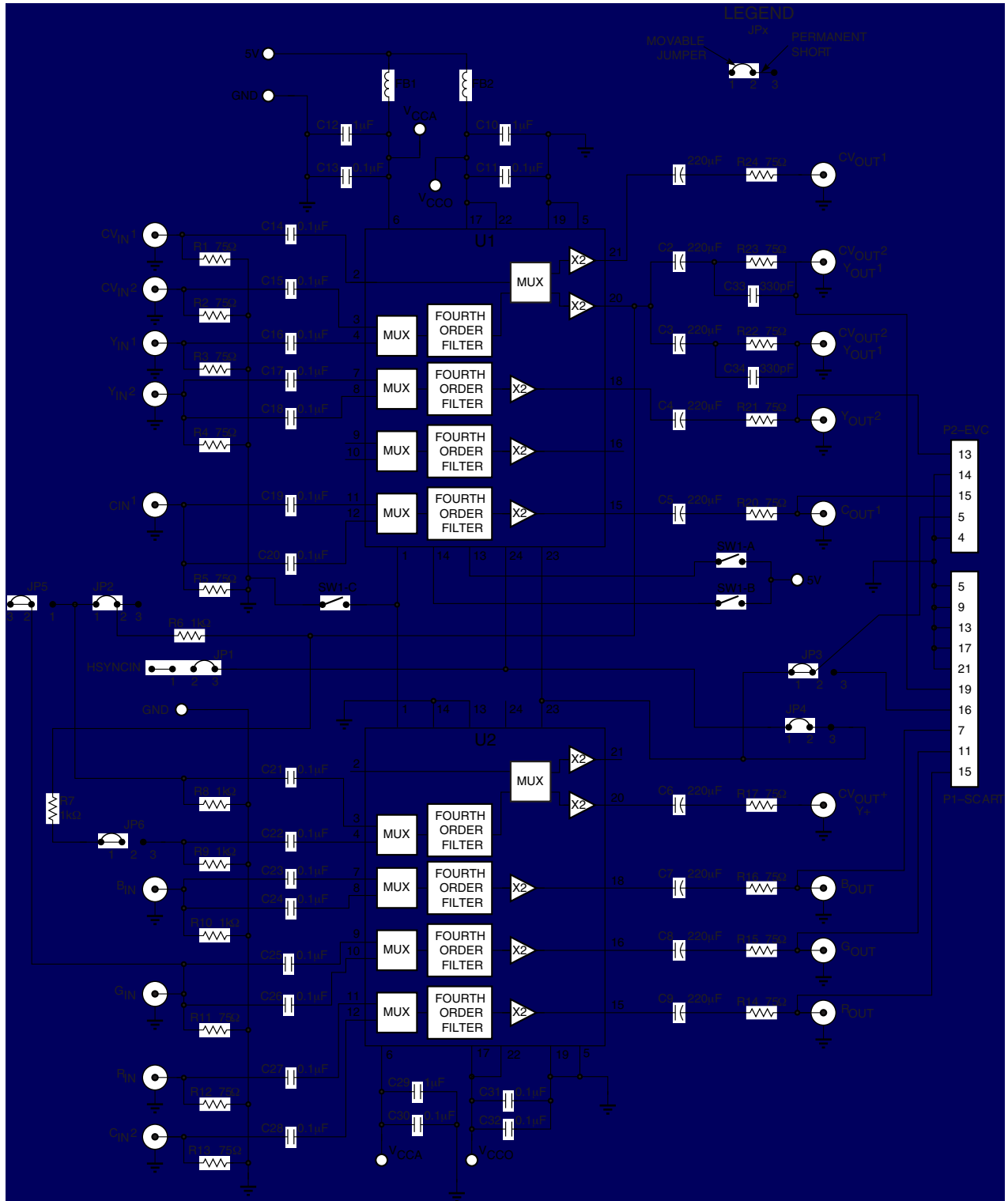

Figure 14. Typical Application Schematic

**Mechanical Dimensions** Inches (Millimeters)



## Ordering Information

Part Number	Temperature Range	Package
ML6427CS	0°C to 70°C	24 Pin SOIC (S24)

### DISCLAIMER

FAIRCHILD SEMICONDUCTOR RESERVES THE RIGHT TO MAKE CHANGES WITHOUT FURTHER NOTICE TO ANY PRODUCTS HEREIN TO IMPROVE RELIABILITY, FUNCTION OR DESIGN. FAIRCHILD DOES NOT ASSUME ANY LIABILITY ARISING OUT OF THE APPLICATION OR USE OF ANY PRODUCT OR CIRCUIT DESCRIBED HEREIN; NEITHER DOES IT CONVEY ANY LICENSE UNDER ITS PATENT RIGHTS, NOR THE RIGHTS OF OTHERS.

### LIFE SUPPORT POLICY

FAIRCHILD'S PRODUCTS ARE NOT AUTHORIZED FOR USE AS CRITICAL COMPONENTS IN LIFE SUPPORT DEVICES OR SYSTEMS WITHOUT THE EXPRESS WRITTEN APPROVAL OF THE PRESIDENT OF FAIRCHILD SEMICONDUCTOR CORPORATION. As used herein:

1. Life support devices or systems are devices or systems which, (a) are intended for surgical implant into the body, or (b) support or sustain life, and (c) whose failure to perform when properly used in accordance with instructions for use provided in the labeling, can be reasonably expected to result in a significant injury of the user.
2. A critical component in any component of a life support device or system whose failure to perform can be reasonably expected to cause the failure of the life support device or system, or to affect its safety or effectiveness.