

QUICK START GUIDE FOR DEMONSTRATION CIRCUIT 429 NEGATIVE 48V HOT SWAP CONTROLLER

LT4250

DESCRIPTION

Demonstration circuit 429 is a Hot Swap™ controller designed for dual -48V battery feeds in telecom subsystems. This demo board is optimized for 2A maximum operating current, making it ideal for loads of 25W to 75W. The LT4250's circuit breaker is immune from transient currents arising from load dump, voltage spikes, and input steps. Provision is made for interfacing the LT4250's "power good" output either directly or via an opto isolator to a power converter, allowing for inclusion of a common mode filter block. The Connection Sense terminal helps eliminate uncontrolled arcing and associated damage to the backplane connector in real-world operating environments.

Design files for this circuit board are available. Call the LTC factory.

QUICK START PROCEDURE

DC429 is designed for either bench evaluation or direct testing by substitution into an existing circuit board. The test setup is straightforward as shown in Figure 1 and Figure 2.

1. Remove the fuses or OR-ing diodes from the existing circuit board.
2. Connect -48V battery feeds to test terminals E3 and E4.
3. Connect the battery feed returns to terminal E1.
4. Attach terminal E2 "Connection Sense" to a short pin on the edge connector, or to a normally open switch contact on the card ejector.

Hot Swap is a trademark of Linear Technology Corporation

Feature Summary:

- OR-ing Diodes on -48V Inputs
- 5A Fuses
- Independent Connection Sense Terminal
- Optically Isolated Power Good Signaling
- On-Board Input and Output Clamps

Table 1. Performance Summary

PARAMETER	VALUE
V _{IN} range (survival)	+100V to -100V
V _{in} range (operating)	≈43V to 70V
UVLO	-38.5V off, -43V on
OV	-71V off, -70V on
Programmed inrush current (100μF)	450mA

The other side of the edge connector or switch must connect to -48V RTN (terminal E1) in order to start the LT4250 Hot Swap controller.

5. Connect ±V_{out} terminals E5 and E9 to the load or power converter module input.
6. Connect PWRGD terminal E6 to the power converter module's ENABLE pin.
7. If a series filter element of any description is present between DC429 and the module, use the opto isolator terminals E7 and E8 to control the module. The opto transistor turns ON when power is GOOD.

QUICK START GUIDE FOR DEMONSTRATION CIRCUIT 429

NEGATIVE 48V HOT SWAP CONTROLLER

8. The board is ready for Hot Swapping.

CONVERSION HINTS

- To convert DC429 to an LT4250H, simply replace Hot Swap controller U1 and use terminal E6, which will behave as a PWRGD (assert high) output. Note that the opto isolator is non-functional when the "H" version of the LT4250 is installed, and serves only as a pull-up.
- As supplied, PWRGD is pulled up by R9 and the opto LED. To eliminate the opto isolator altogether, remove R9 (30k Ω). Position R8 is provided in case a purely resistive pull-up path is desired (see Schematic Diagram).

- Large wires may overwhelm the turret terminals. These terminals are *not* swaged and can be easily removed by desoldering. The holes are 0.095 inches in diameter, suitable for wire sizes up to 12 AWG solid or stranded.
- DC429 can be adapted for use at higher currents by resizing the MOSFET, sense resistor, ORing diodes, and fuses. The minimum trace width is 300mils, allowing for currents of up to 15A. (The boards are built with 1-ounce foil).
- Do not attempt to measure the MOSFET gate voltage directly with a scope probe or a voltmeter. Measure instead the junction of R2 and R3, or at pin 6 (GATE of the LT4250).

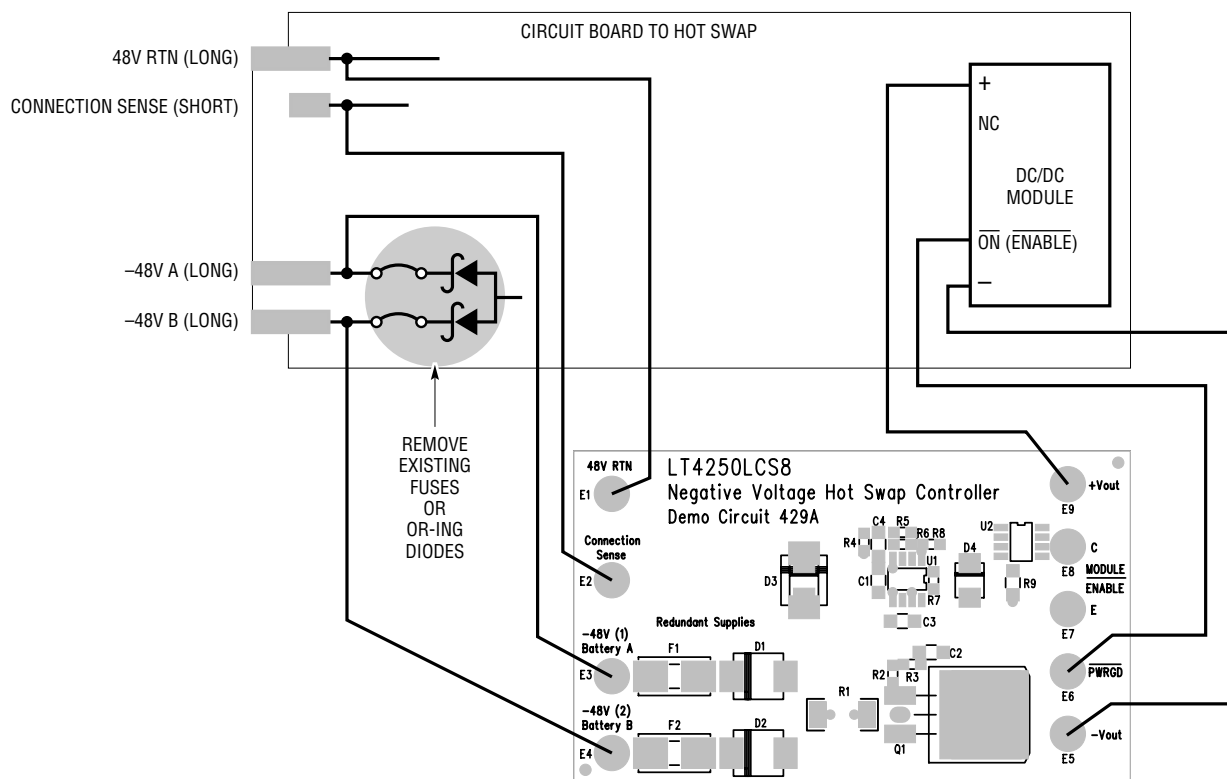

Figure 1. Setup for Circuit Board with no Input Filter

QUICK START GUIDE FOR DEMONSTRATION CIRCUIT 429

NEGATIVE 48V HOT SWAP CONTROLLER

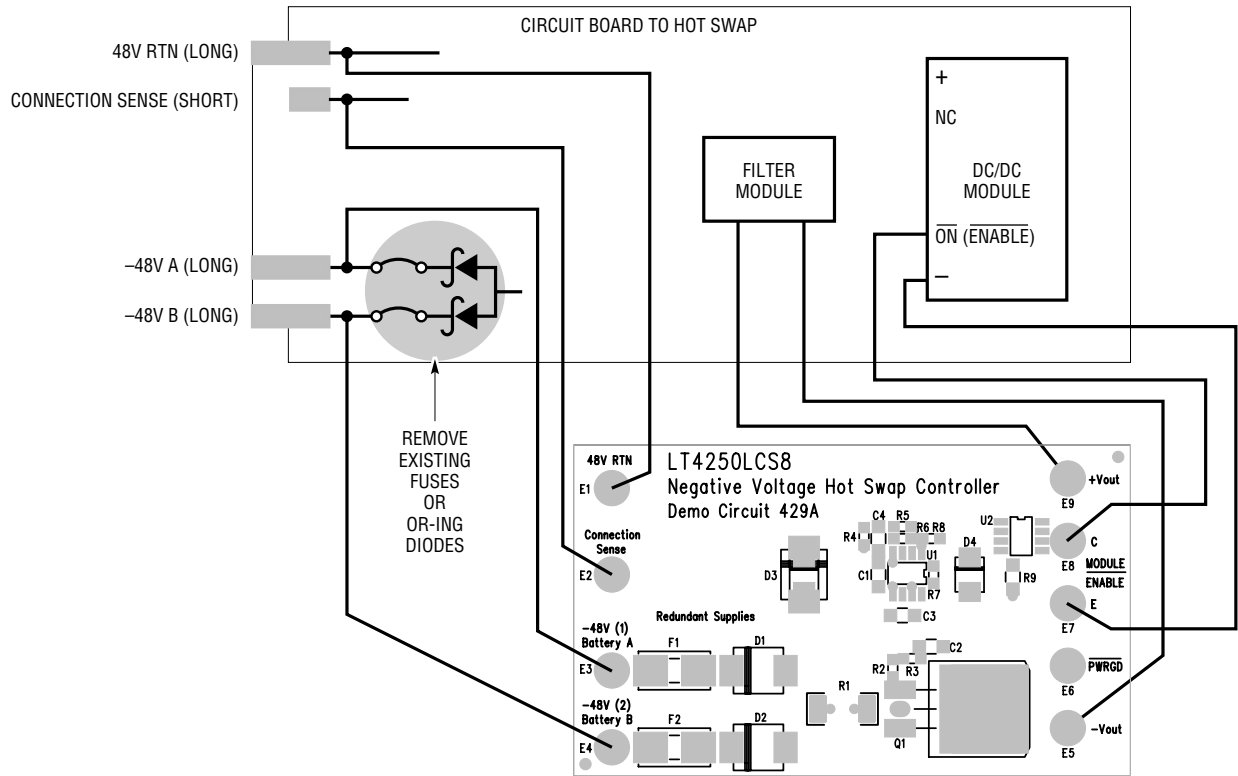

Figure 2. Setup for Circuit Board with Input Filter