

MATERIALS & SPECIFICATIONS

PART NO.	A 79101-001	REV	ECO	DATE	APP
		D	98556	05-18-12	TLM

INSULATOR:

THERMOPLASTIC POLYMER PER MIL-DTL-32139

CONTACT:

COPPER ALLOY PER MIL-DTL-32139, GOLD PLATED PER ASTM B488, (HARD GOLD) TYPE II CODE C CLASS 1.27

TERMINATION:

32 AWG (7-40) TYPE ET, PER NEMA HP3, COLOR CODED PER TABLE

CURRENT CAPACITY:

1 AMP MAX PER MIL-DTL-32139

CONTACT RESISTANCE:

71 MILLIOHM (71mV) MAX @ 1.0 AMPS PER MIL-DTL-32139



ACTUAL SIZE
EXCLUDING WIRE LENGTH

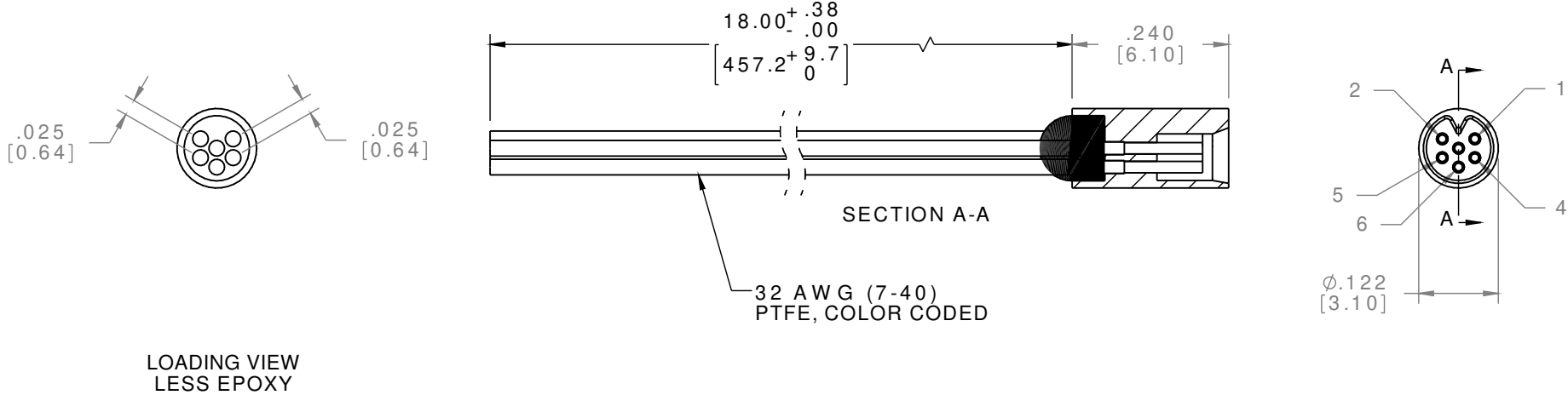

LOADING VIEW
LESS EPOXY

SOCKET #	COLOR
1	BLACK
2	BROWN
3	RED
4	ORANGE
5	YELLOW
6	GREEN

INTERNAL USE ONLY

USE MFG. LOADING
PROCEDURE NC-6S

RoHS

NCS SLDW	THIRD ANGLE	THIS DRAWING CONTAINS CONFIDENTIAL AND PROPRIETARY INFORMATION WHICH IS THE PROPERTY OF OMNETICS CONNECTOR CORP. THIS DOCUMENT MAY NOT, IN WHOLE OR IN PART, BE DUPLICATED, OR DISCLOSED FOR ANY PURPOSE, WITHOUT WRITTEN PERMISSION FROM OMNETICS CONNECTOR CORP.		CAGE CODE 61873
	-TOLERANCES- UNLESS OTHERWISE NOTED DIMENSIONS IN INCHES	DFTM. TLM	DATE 01-14-09	
	2 PL DEC ± .01 3 PL DEC ± .005 4 PL DEC ± .0005 ANGLES ± 1°	CHK'D.	DATE	OMNETICS CONNECTOR CORPORATION 7260 COMMERCE CIRCLE EAST MINNEAPOLIS, MN 55432 WWW.OMNETICS.COM
		APP'D.	DATE	SCALE: 4:1
				REV D