

LOC		DIST		REVISIONS			
P	LTR	DESCRIPTION	DATE	DWN	APVD		
E		PER EC 0514-0184-04	06JAN05	BM	JL		

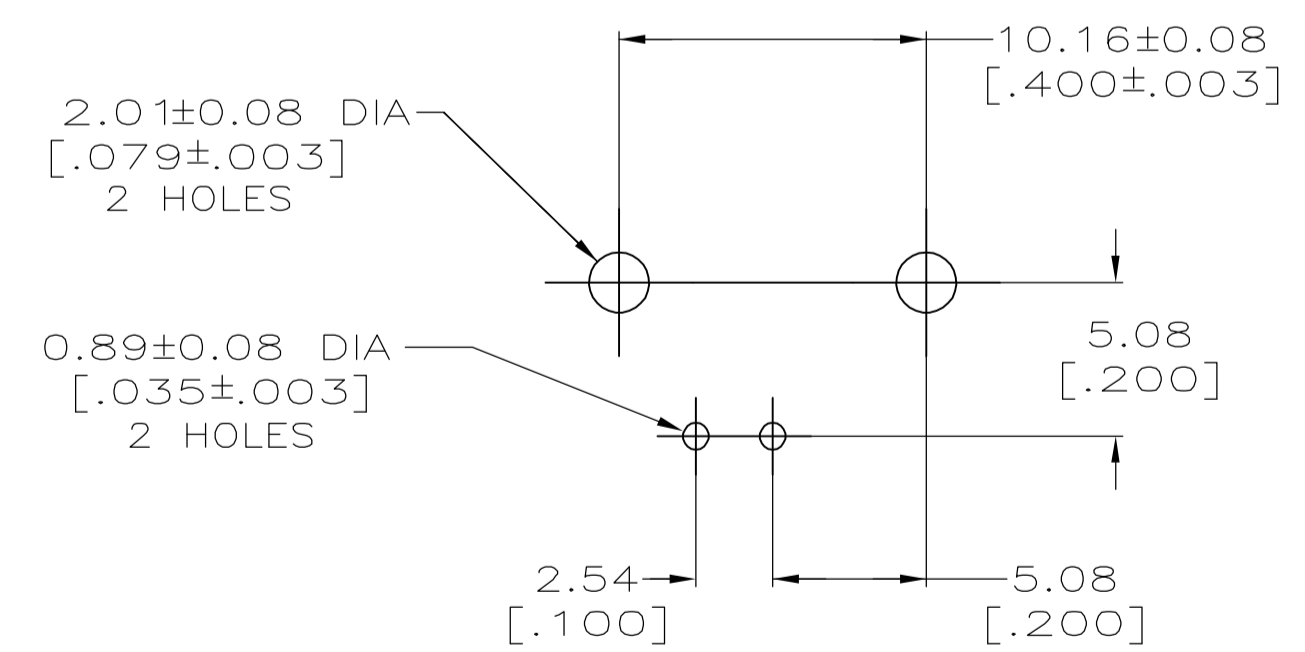
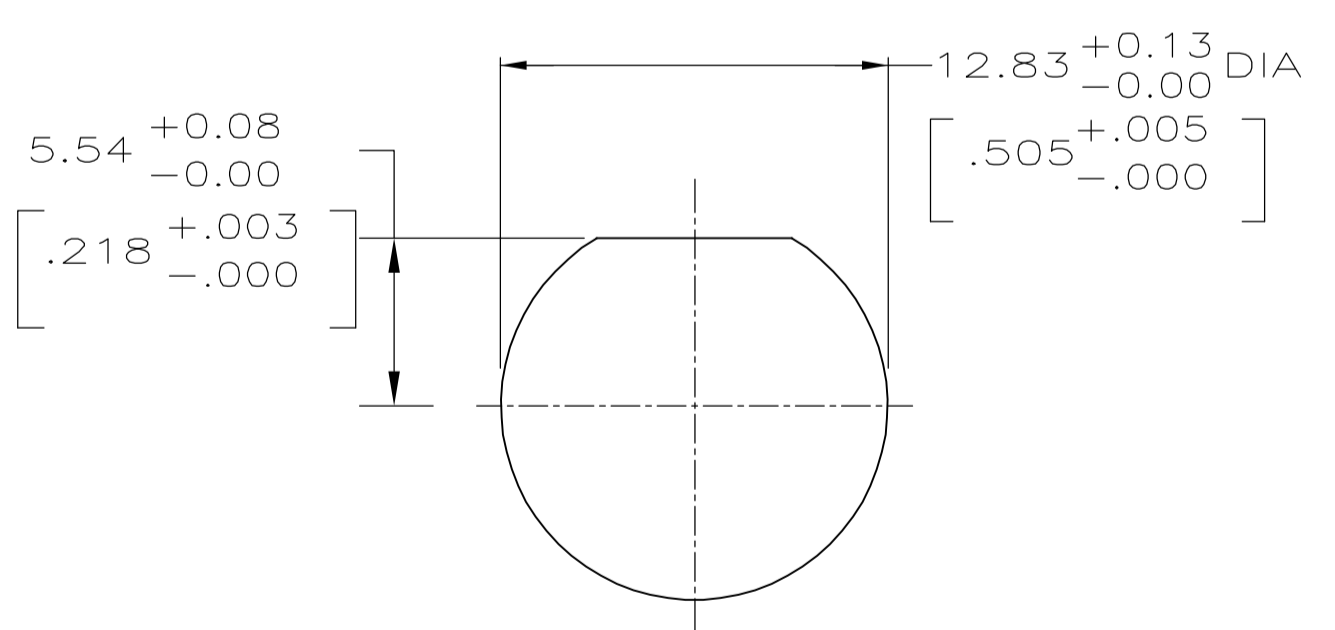
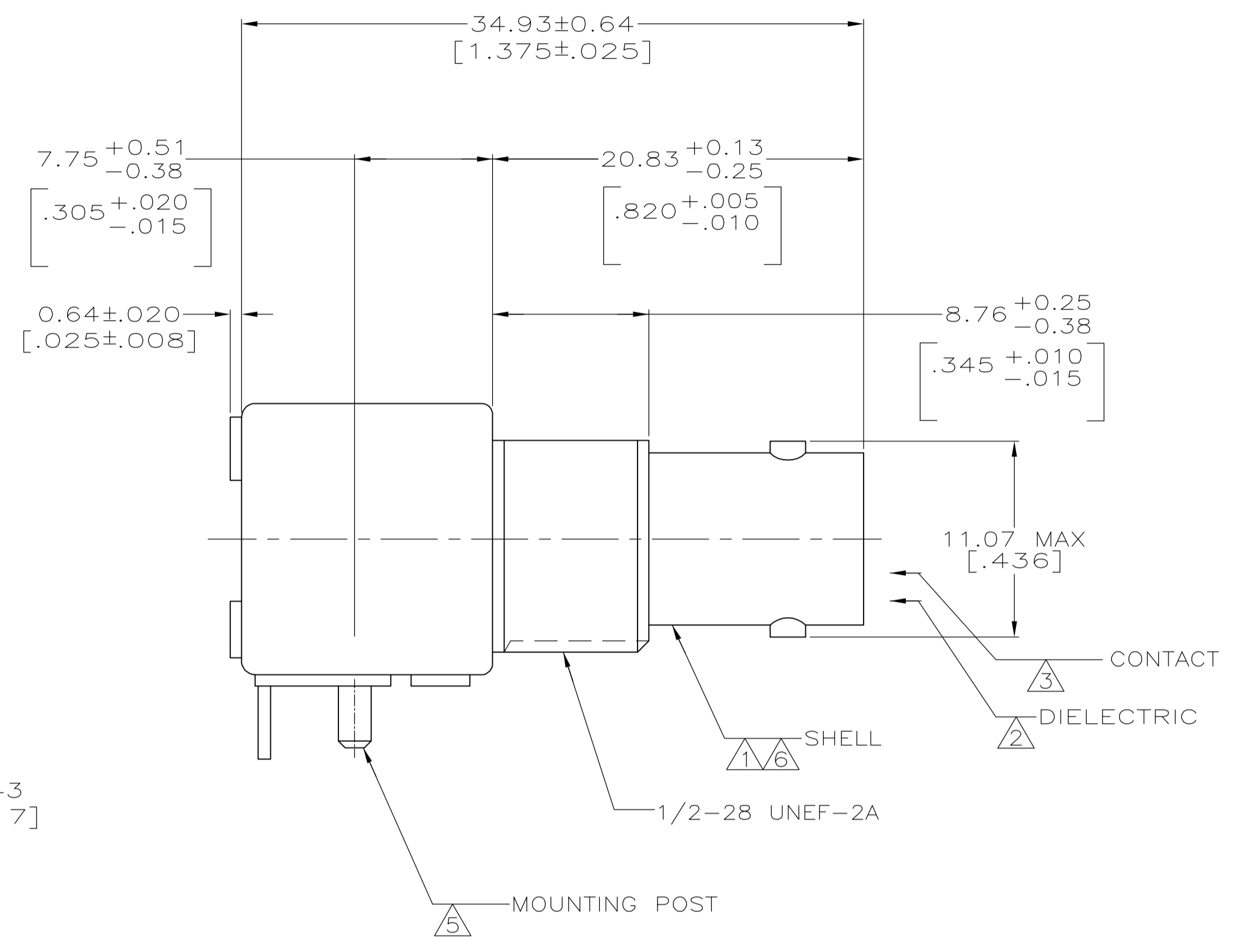
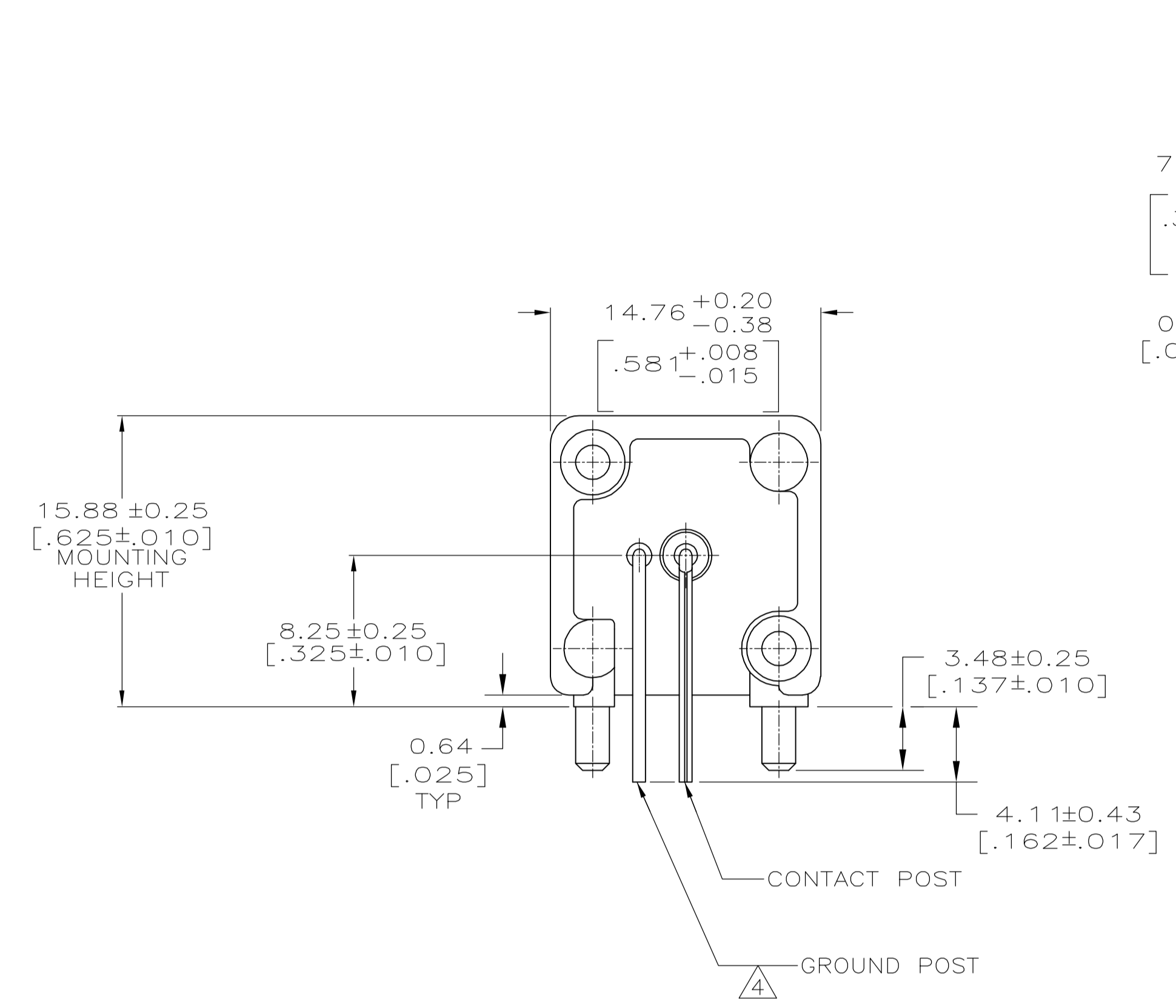

- ① ZINC PER QQ-Z-363.
- ② POLYMETHYLPENTENE PER ASTM-D-1238.
- ③ PHOSPHOR BRONZE PER QQ-B-750.
- ④ BRASS PER ASTM-B-453.
- ⑤ BRASS PER ASTM-B-16.
- ⑥ NICKEL PLATE PER QQ-N-290, 3.81 μm [.000150] MINIMUM THICK.
- ⑦ TIN PLATE PER ASTM-B-545, 3.81 μm [.000150] MINIMUM THICK.
- ⑧ SEE INSTRUCTION SHEET 2769.
- ⑨ TIN PLATE PER ASTM-B-545, 3.81 μm [.000150] MINIMUM THICK.

SUPERSEDED BY 227661-1	⑨	⑨	⑨	⑨	⑨	9-227661-0
	⑦	⑦	⑦	⑦	⑦	227661-2
	⑦	⑦	⑦	⑦	⑦	227661-1
	GROUND POST PLATING	CONTACT POST PLATING	MOUNTING POST PLATING	CONTACT PLATING	SHELL ASSY PLATING	PART NUMBER

THIS DRAWING IS A CONTROLLED DOCUMENT.

DIMENSIONS: INCHES	TOLERANCES UNLESS OTHERWISE SPECIFIED:	DIN J. LIPPERT 6-29-92	Tyco Electronics Corporation Harrisburg, PA 17105-3608
0 PLC ± -	1 PLC ± -	7-2-92	
2 PLC ± 0.05 [.002]	3 PLC ± -	APVD J. LIPPERT 07-30-82	NAME
4 PLC ± -	ANGLES ± -	PRODUCT SPEC	JACK, RIGHT ANGLE, PCB
MATERIAL FINISH	FINISH	APPLICATION SPEC	50 OHM, SERIES BNC
① ② ③ ④ ⑤	⑥ ⑦ ⑧ ⑨	SIZE CAGE CODE DRAWING NO	RESTRICTED TO
		WEIGHT	A1 00779 C=227661
		CUSTOMER DRAWING	SCALE 4:1 SHEET 1 OF 1 REV E