

100 V field-effect rectifier diode

Datasheet - production data

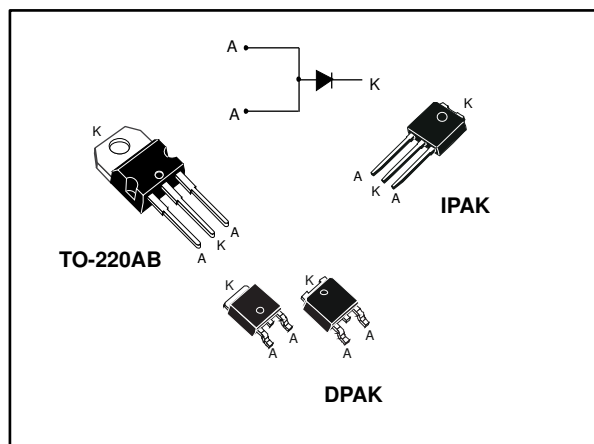

Description

The device is based on a proprietary technology that achieves the best in class V_F/I_R trade-off for a given silicon surface. This 100 V rectifier has been optimized for use in confined casing applications where both efficiency and thermal performance matter. With a lower dependency of leakage current (I_R) and forward voltage (V_F) in function of temperature, the thermal runaway risk is reduced. Therefore, it can advantageously replace 100 V Schottky diodes.

Table 1: Device summary

Symbol	Value
$I_{F(AV)}$	20 A
V_{RRM}	100 V
$V_F(max.)$	0.415 V
$I_R(max.)$	110 μ A
$T_j(max.)$	175 °C

Features

- ST advanced rectifier process
- Stable leakage current over reverse voltage
- Reduced leakage current
- Low forward voltage drop
- High frequency operation
- ECOPACK[®]2 compliant component

1 Characteristics

Table 2: Absolute ratings (limiting values at 25 °C, unless otherwise specified, anode terminals short-circuited)

Symbol	Parameter		Value	Unit	
V _{RRM}	Repetitive peak reverse voltage		100	V	
I _{F(RMS)}	Forward rms current		40	A	
I _{F(AV)}	Average forward current $\delta = 0.5$, square wave	T _C = 150 °C	20	A	
I _{FSM}	Surge non repetitive forward current	t _p = 10 ms sinusoidal	TO-220AB	220	A
			DPAK, IPAK	150	A
T _{stg}	Storage temperature range		-65 to +175	°C	
T _j	Maximum operating junction temperature ⁽¹⁾		175	°C	

Notes:

⁽¹⁾(dP_{tot}/dT_j) < (1/R_{th(j-a)}) condition to avoid thermal runaway for a diode on its own heatsink.

Table 3: Thermal resistance parameters

Symbol	Parameter	Value	Unit
R _{th(j-c)}	Junction to case	1.3	°C/W

Table 4: Static electrical characteristics (anode terminals short circuited)

Symbol	Parameter	Test conditions		Min.	Typ.	Max.	Unit
I _R ⁽¹⁾	Reverse leakage current	T _j = 25 °C	V _R = V _{RRM}	-		110	μA
		T _j = 125 °C		-	6	12	mA
		T _j = 125 °C	V _R = 70 V	-	3	6	
V _F ⁽²⁾	Forward voltage drop	T _j = 25 °C	I _F = 2 A	-	0.395	0.445	V
		T _j = 125 °C		-	0.36	0.415	
		T _j = 25 °C	I _F = 5 A	-	0.520	0.585	
		T _j = 125 °C		-	0.500	0.555	
		T _j = 25 °C	I _F = 10 A	-	0.680	0.780	
		T _j = 125 °C		-	0.600	0.660	
		T _j = 125 °C		I _F = 20 A	-	0.690	

Notes:

⁽¹⁾Pulse test: t_p = 5 ms, $\delta < 2\%$

⁽²⁾Pulse test: t_p = 380 μs, $\delta < 2\%$

To evaluate the conduction losses use the following equation:

$$P = 0.45 \times I_{F(AV)} + 0.021 \times I_{F(RMS)}^2$$

1.1 Characteristics (curves)

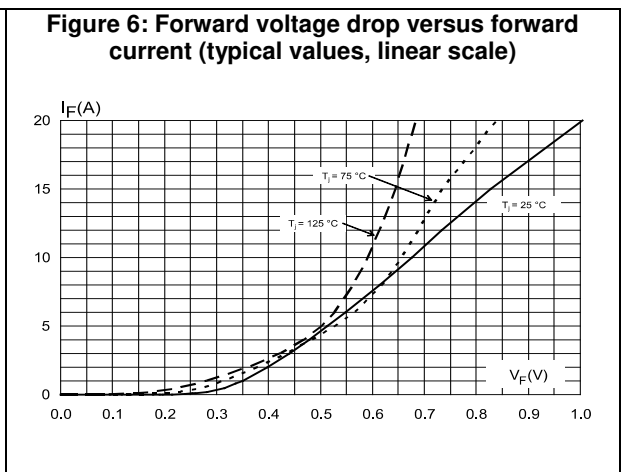
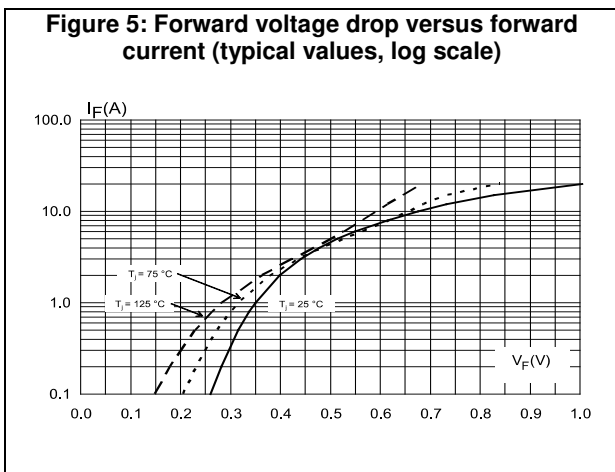
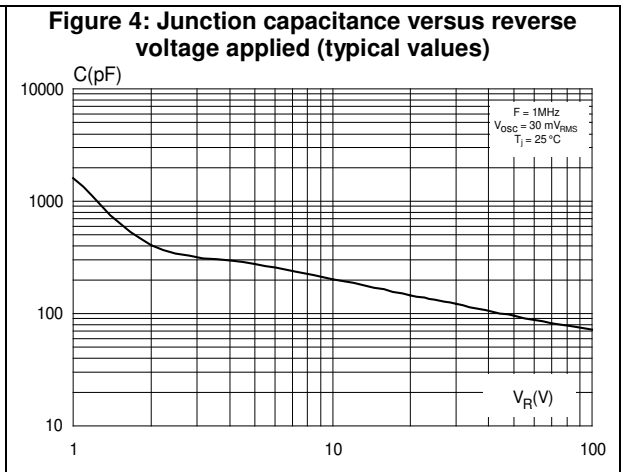
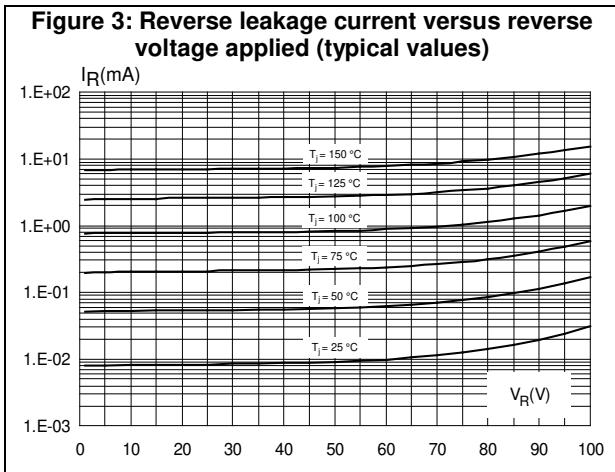
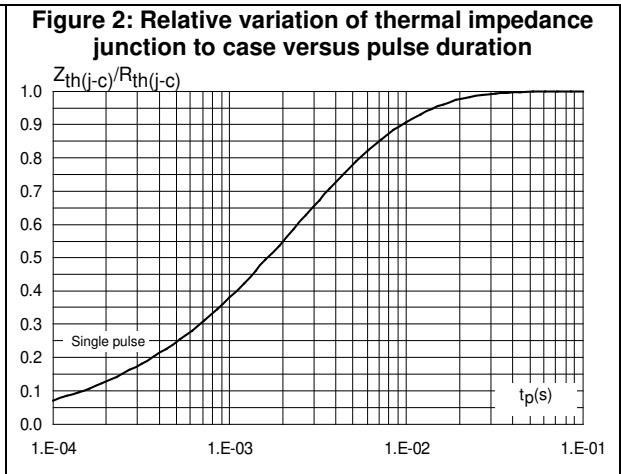
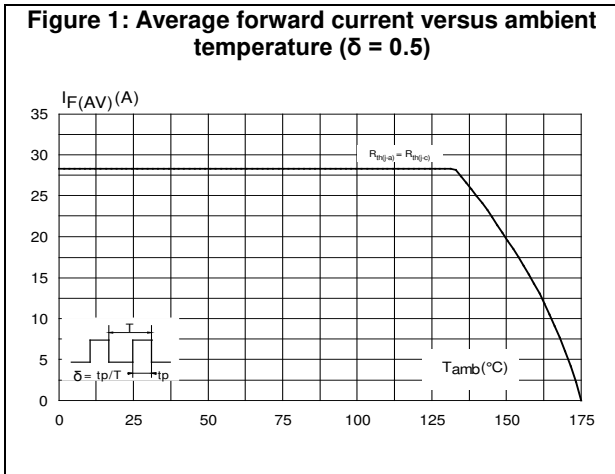
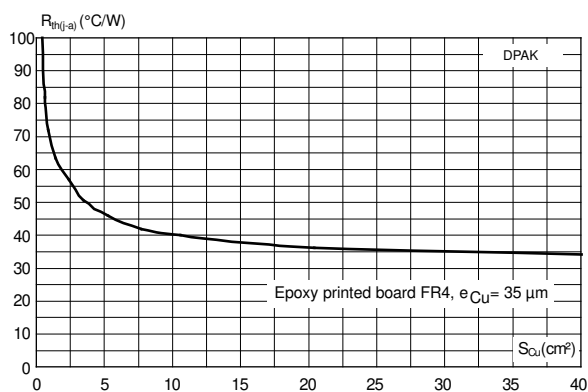

Figure 7: Thermal resistance junction to ambient versus copper surface under tab for DPAK (typical values)



2 Package information

In order to meet environmental requirements, ST offers these devices in different grades of ECOPACK® packages, depending on their level of environmental compliance. ECOPACK® specifications, grade definitions and product status are available at: www.st.com. ECOPACK® is an ST trademark.

- Cooling method: by conduction (C)
- Epoxy meets UL 94, V0
- Recommended torque value: 0.55 N·m (for TO-220AB)
- Maximum torque value: 0.6 N·m (for TO-220AB)

2.1 IPAK package information

Figure 8: IPAK package outline

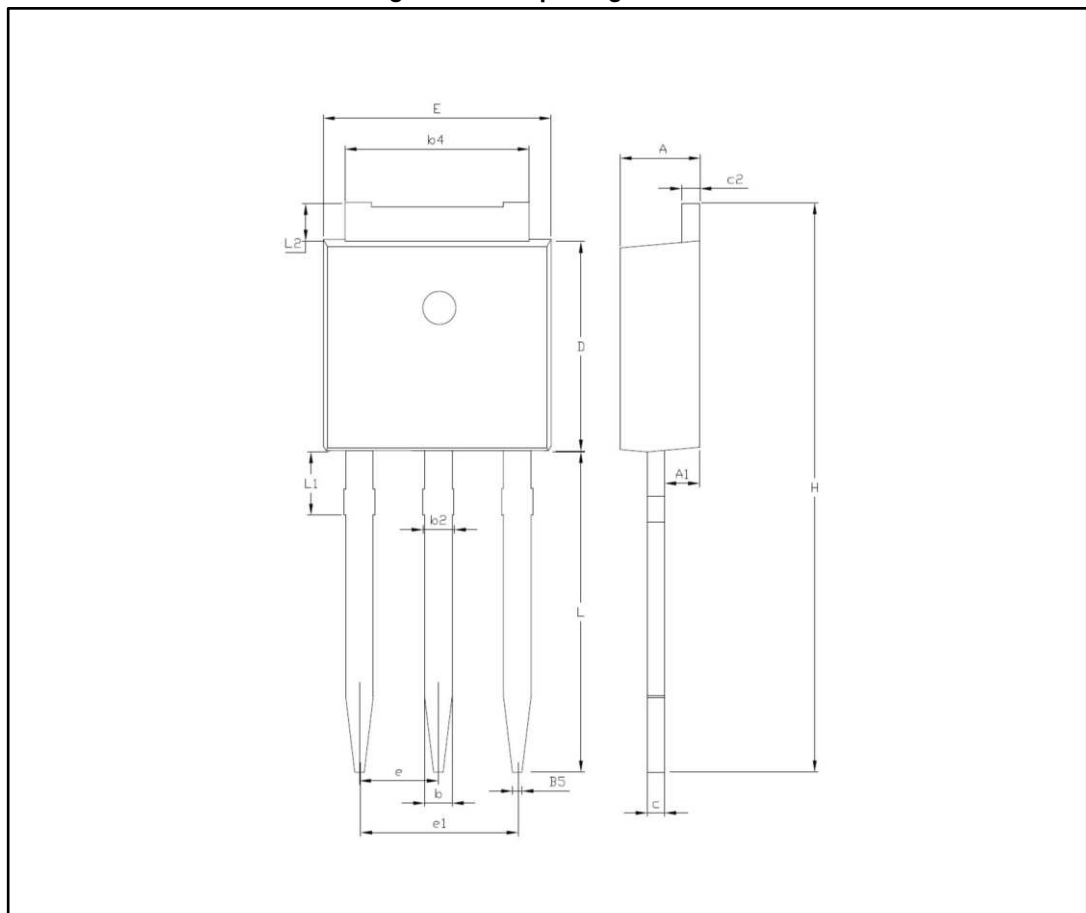

Table 5: IPAK package mechanical data

Ref.	Dimensions			
	Millimeters		Inches	
	Min.	Max.	Min.	Max.
A	2.20	2.40	0.087	0.094
A1	0.90	1.10	0.035	0.043
b	0.64	0.90	0.025	0.035
b2		0.95		0.037
b4	5.20	5.43	0.205	0.214
B5	0.30 typ.		0.012 typ.	
c	0.45	0.60	0.018	0.024
c2	0.46	0.60	0.018	0.024
D	6.00	6.20	0.236	0.244
E	6.40	6.65	0.252	0.261
e	2.28 typ.		typ.0.090	
e1	4.40	4.60	0.173	0.181
H	16.10 typ.		0.634 typ.	
L	9.0	9.60	0.354	0.378
L1	0.80	1.20	0.031	0.047
L2	0.80 typ.	1.25	0.031 typ.	0.049
V1	+10°		+10	

Table 6: DPAK package mechanical data

Ref.	Dimensions			
	Millimeters		Inches	
	Min.	Max.	Min.	Max.
A	2.18	2.40	0.085	0.094
A1	0.90	1.10	0.035	0.043
A2	0.03	0.23	0.001	0.009
b	0.64	0.90	0.025	0.035
b4	4.95	5.46	0.194	0.215
c	0.46	0.61	0.018	0.024
c2	0.46	0.60	0.018	0.023
D	5.97	6.22	0.235	0.244
D1	4.95	5.60	0.194	0.220
E	6.35	6.73	0.250	0.265
E1	4.32	5.50	0.170	0.216
e	2.286 typ.		0.090 typ.	
e1	4.40	4.70	0.173	0.185
H	9.35	10.40	0.368	0.409
L	1.0	1.78	0.039	0.070
L2		1.27		0.050
L4	0.60	1.02	0.023	0.040
V2	-8°	+8°	-8°	+8°

Figure 10: DPAK recommended footprint (dimensions in mm)

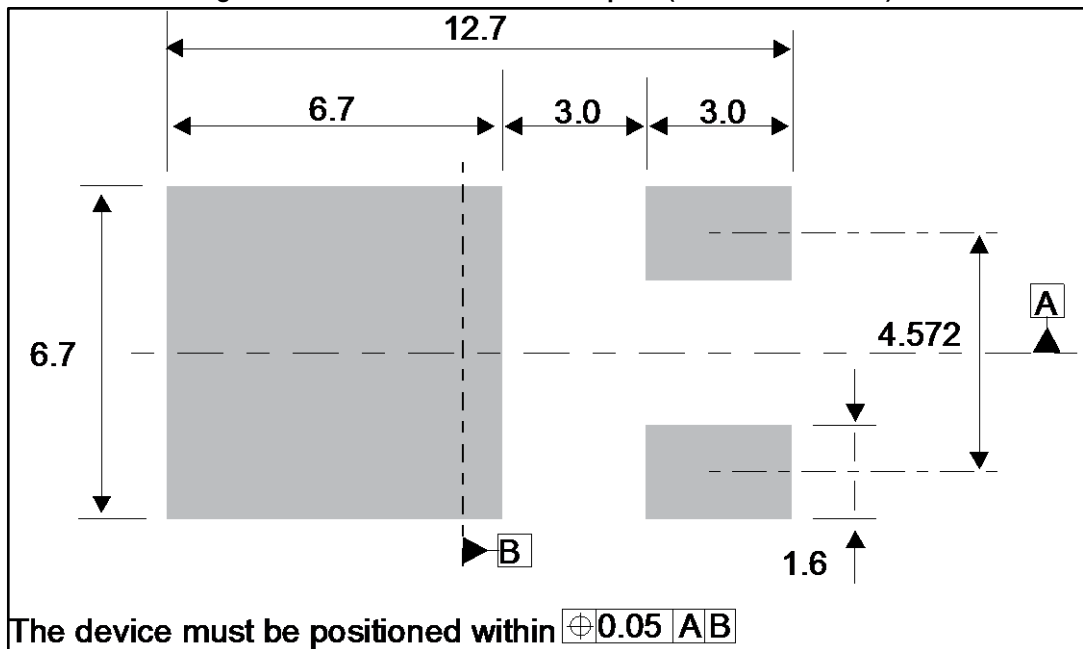

2.3 TO-220AB package information

Figure 11: TO-220AB package outline

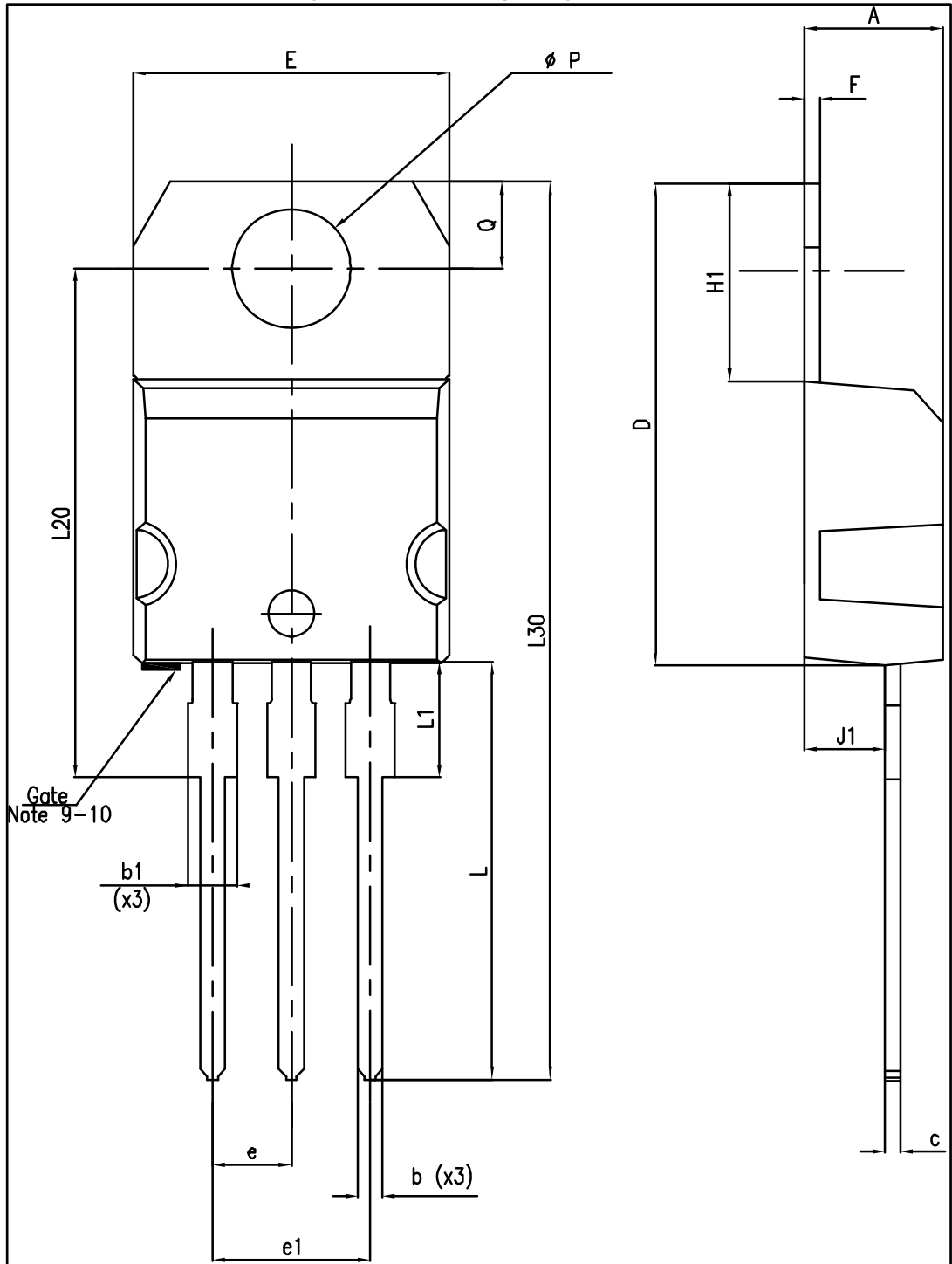

Table 7: TO-220AB package mechanical data

Ref.	Dimensions			
	Millimeters		Inches	
	Min.	Max.	Min.	Max.
A	4.40	4.60	0.173	0.181
b	0.61	0.88	0.024	0.035
b1	1.14	1.70	0.045	0.067
c	0.48	0.70	0.019	0.028
D	15.25	15.75	0.600	0.620
E	10.00	10.40	0.394	0.409
e	2.40	2.70	0.094	0.106
e1	4.95	5.15	0.195	0.203
F	0.51	0.60	0.020	0.024
J1	2.40	2.72	0.094	0.107
H1	6.20	6.60	0.244	0.256
L	13.00	14.00	0.512	0.551
L1	3.50	3.93	0.138	0.155
L20	16.40 typ.		0.646 typ.	
L30	28.90 typ.		1.138	
Ø P	3.75	3.85	0.148	0.156
Q	2.65	2.95	0.104	0.116

3 Ordering information

Table 8: Ordering information

Order code	Marking	Package	Weight	Base qty.	Delivery mode
FERD20S100STS	FD20S100STS	TO-220AB	1.38 g	50	Tube
FERD20S100SB-TR	FD20 S100S	DPAK	0.35 g	2500	Tape and reel
FERD20S100SH	FD20 S100S	IPAK	0.32 g	75	Tube

4 Revision history

Table 9: Document revision history

Date	Revision	Changes
03-Jun-2016	1	Initial release.
14-Nov-2017	2	Updated cover page.

IMPORTANT NOTICE – PLEASE READ CAREFULLY

STMicroelectronics NV and its subsidiaries ("ST") reserve the right to make changes, corrections, enhancements, modifications, and improvements to ST products and/or to this document at any time without notice. Purchasers should obtain the latest relevant information on ST products before placing orders. ST products are sold pursuant to ST's terms and conditions of sale in place at the time of order acknowledgement.

Purchasers are solely responsible for the choice, selection, and use of ST products and ST assumes no liability for application assistance or the design of Purchasers' products.

No license, express or implied, to any intellectual property right is granted by ST herein.

Resale of ST products with provisions different from the information set forth herein shall void any warranty granted by ST for such product.

ST and the ST logo are trademarks of ST. All other product or service names are the property of their respective owners.

Information in this document supersedes and replaces information previously supplied in any prior versions of this document.

© 2017 STMicroelectronics – All rights reserved