

REVISIONS					
REV	ECO	DESCRIPTION	DATE	BY	APPR
A1	-	FIRST RELEASE	Oct.30,2017	White	Tommy

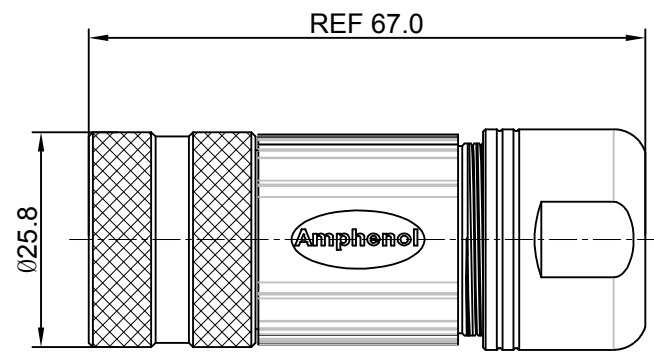

E type, Normal Key  
(E型, 0转位角)

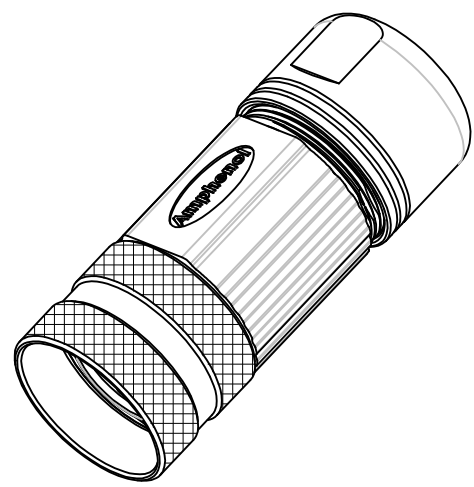
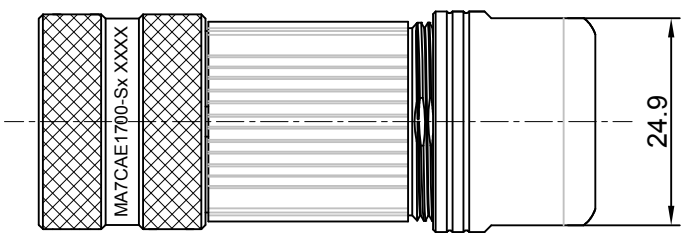
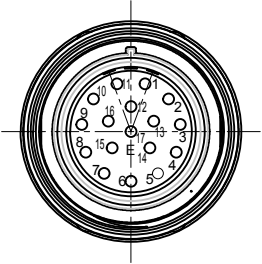

NOTES: UNLESS OTHERWISE SPECIFIED

- MATERIAL:  
INSULATION INSERT: PA66,UL94 V0  
SEAL: VITON, EPDM  
HOUSING BODY: ZINC DIE CAST, NICKEL PLATED  
COUPLING NUT: COPPER ALLOY, NICKEL PLATED  
CONTACT: COPPER ALLOY, GOLD PLATED
- SPECIFICATIONS:  
2.1 CURRENT RATING: 9 AMPS  
2.2 VOLTAGE RATING: 125 V AC/DC  
2.3 CONTACT RESISTANCE: <5 mOHMS  
2.4 OPERATING TEMPERATURE: -20°C TO +130°C  
2.5 DIELECTRIC WITHSTANDING VOLTAGE: LESS THAN 2 MILLIAMPS CURRENT LEAKAGE @ 2500 VOLTS AC.  
2.6 DEGREE OF PROTECTION: IP67 ( MATED CONDITION )  
2.7 DEGREE OF POLLUTION: 3 PER UL840  
2.8 OVERVOLTAGE CATEGORY: III PER UL840  
2.9 MATING CYCLE DURABILITY: >500 CYCLES  
2.10 RoHS COMPLIANT
- ALL DIMENSIONS ARE FOR REFERENCE USE ONLY.

Item	Part number	Connector P/N	Cable OD Range
1	MA7CAE1700S-S1-KIT	MA7CAE1700-S1	4.5~7.5 mm
2	MA7CAE1700S-S2-KIT	MA7CAE1700-S2	7.5~11.0 mm
3	MA7CAE1700S-S3-KIT	MA7CAE1700-S3	11.0~15.0 mm

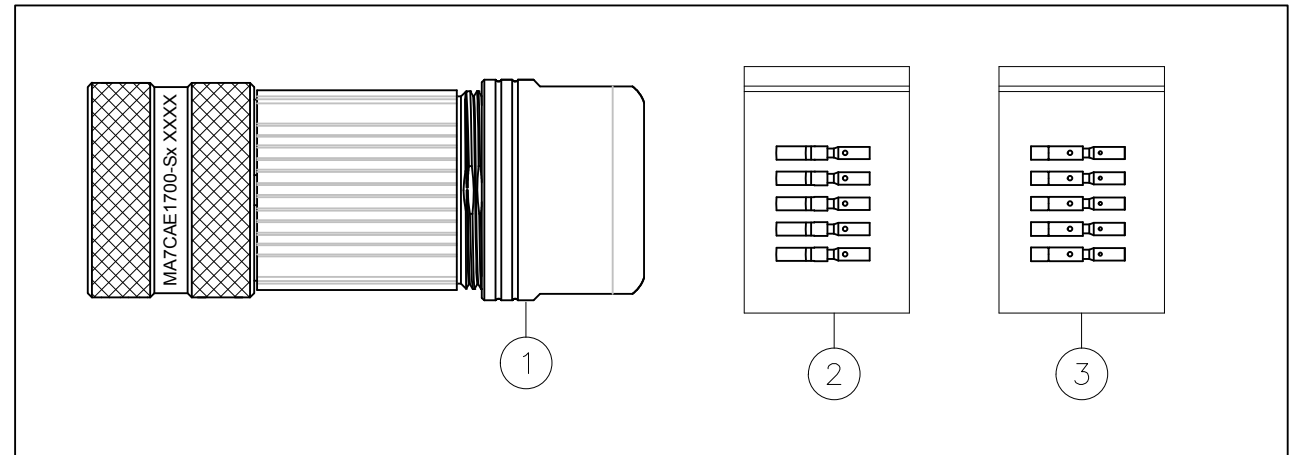

17	SC000030	CONTACT, SOCKET, Ø1.0mm,CRIMP 24~28AWG	3
17	SC000044	CONTACT, SOCKET, Ø1.0mm,CRIMP 18~22AWG	2
1	MA7CAE1700-Sx	CONNECTOR	1
QUANTITY	PART NUMBER	DESCRIPTION	ITEM

MATERIALS LIST			
SIGNATURES		DATE	
DRAWN:	White	Oct.30,17	
CHECKED:	Tod	Oct.30,17	
ENGINEER:			
APPROVAL:	Tommy	Oct.30,17	
MATERIAL SPECIFICATIONS:		CUSTOMER:	
PROCESS SPECIFICATIONS:		THIS DRAWING IS SUPPLIED FOR INFORMATION ONLY. DESIGN FEATURES, SPECIFICATIONS AND PERFORMANCE DATA SHOWN HEREON ARE THE PROPERTY OF THE AMPHENOL CORPORATION. NO RIGHTS OF REPRODUCTION ARE IMPLIED. ALL DIMENSIONS ARE SUBJECT TO NORMAL MANUFACTURING VARIATIONS.	
NEXT ASSY:		SCALE: NONE	SHEET 1 OF 1

# Amphenol

Sine Systems - www.amphenol-sine.com  
44724 Morley Drive  
Clinton Township, MI 48036

**KIT;M23A,PLUG,STR,17P,E TYPE**

SIZE	TYPE	DWG NO:	REVISION
B	C-	MA7CAE1700S-Sx-KIT	A1

TITLE: KIT;M23A,PLUG,STR,17P,E TYPE  
DWG NO: MA7CAE1700S-Sx-KIT  
REV: A1  
SH: 1  
OF: 1