

6

5

4

3

2

1

APPROVED: _____

DATE: _____ TITLE: _____

Rev	AWO #	Description	Date	Appr
-		RELEASED	11/12/18	

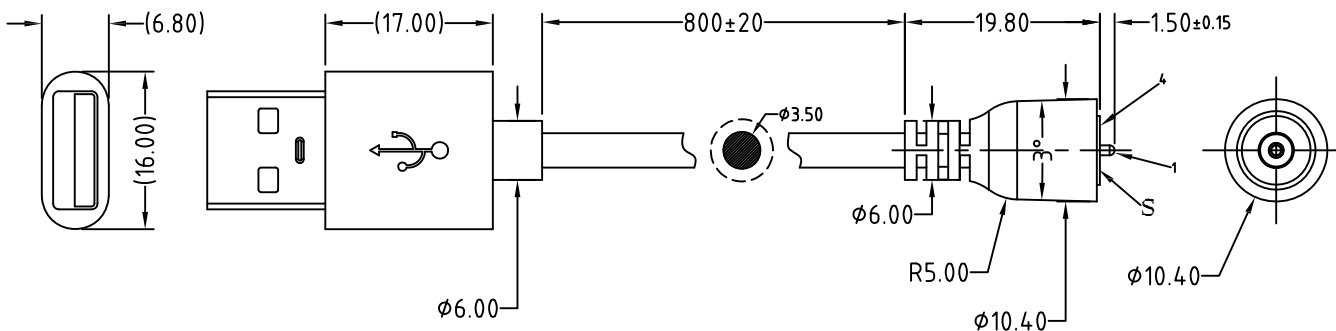

USB → Wire → CONN	
Vcc_1+_red	→ 1 → Pin
GND_4-Black	→ 4 → Shell

SPECIFICATIONS:

Connector:

P1 = USB Type-A Male, Insulator Color: Black, Contact: Gold flash plated
Overmold Color: Black, 45P PVC, Salt spray test: 48H

P2 = Circular POGO Pin connector Male, Straight Overmold Color: Black, 45P PVC

Cable:

22AWG, 2C, O.D.: .138" [3.5mm], Jacket Color: Black, PVC 55P

Electrical:

Rated Current & Voltage: 12VDC, 3A

Contact resistance: 50 mohms max

Mechanical:

Contact force: 80±20g @ 1.10mm working stroke

Full stroke: 1.60mm

Durability: 100,000 Cycles

Electrical Test:

All Assemblies must be 100% Tested for
Shorts, Open, Continuity, and Physical Appearance.

Environmental:

Lead free, RoHS compliant.



Mating with: PHR-C4777-02-FVP-800

UNLESS OTHERWISE SPECIFIED ALL DIMENSIONS ARE MILLIMETERS TOLERANCES: EXCEPT AS NOTED Millimeters ANGLE		ADAM TECH		909 Rahway Avenue, Union, NJ 07083 Phone: 908-687-5000 Fax: 908-687-5710	
0~6 ± 0.10		INTERCONNECTS		TITLE	
6~30 ± 0.20				POGO PIN CHARGING CABLE, MALE, STRAIGHT	
30~150 ± 0.30				REV.	
APPROVALS		DATE		SIZE	
DRAWN	HR	11/12/18		PART NO.	
CHECKED	CK	11/12/18		CA-ST2-PHR-198-M	
APPROVED				REF: S00170C	
				SCALE: NTS	
				SHEET 1 OF 1	

6

5

4

3

2

1