

THESE DRAWINGS ARE THE PROPERTY OF QUALTEK ELECTRONICS AND NOT TO BE REPRODUCED FOR OR COMMUNICATED TO A THIRD PARTY WITHOUT THE EXPRESS WRITTEN PERMISSION OF AN OFFICER OF QUALTEK ELECTRONICS.

REVISION			
REV.	DESCRIPTION	DATE	APPROVED
B	RoHS Compliancy	06-01-06	DP

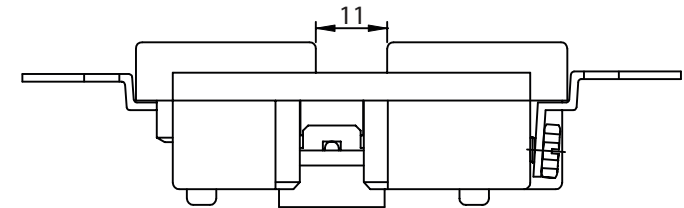
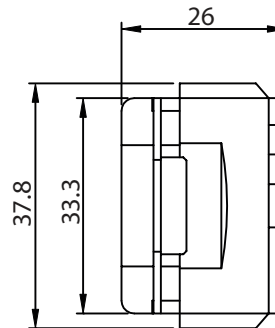
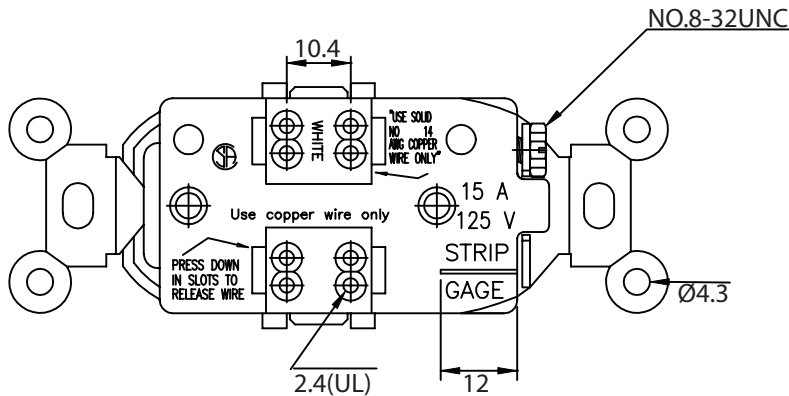
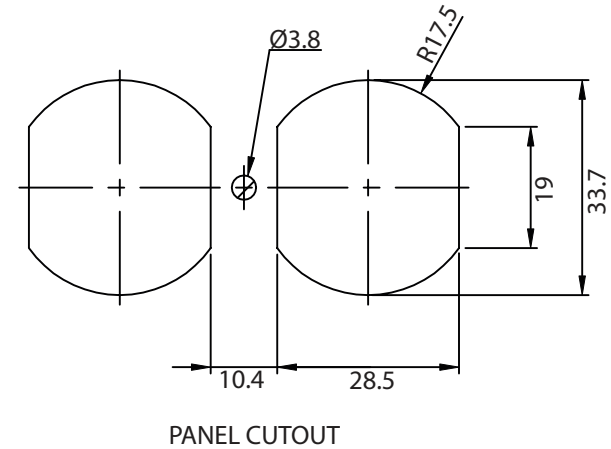
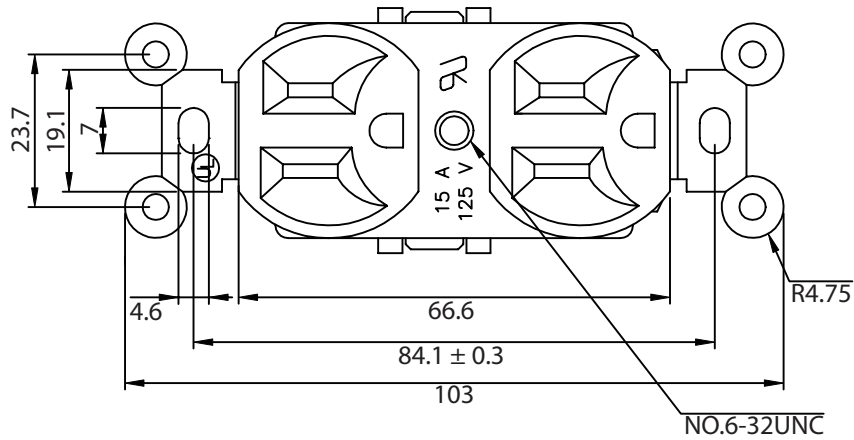

NOTES:

USE SOLID 14AWG COPPER WIRE ONLY
 RATING: 15A 125V AC
 APPROVALS: UL,CSA
 COLOR: GREEN
 RoHS COMPLIANT

CONTROLLED

Dim range (mm)	Tolerance +/- (mm)	Qualtek Electronics Corp. PPC DIVISION		
0-1	0.15	Part Number:	740W-C/03	RoHS Compliant
1-6	0.20	Description:	AC RECEPTACLE	
6-18	0.30		UNIT: mm	REV. B
18-50	0.50	Drawn / Date	Checked / Date	Approved / Date
50-120	0.70	B.Zhang 06-19-02	06-19-02	JJH / 06-19-02
120-250	0.90			
250-500	1.20			