

DO NOT SCALE FROM THIS PRINT

DESIGNED & DIMENSIONED IN MILLIMETERS [INCHES]

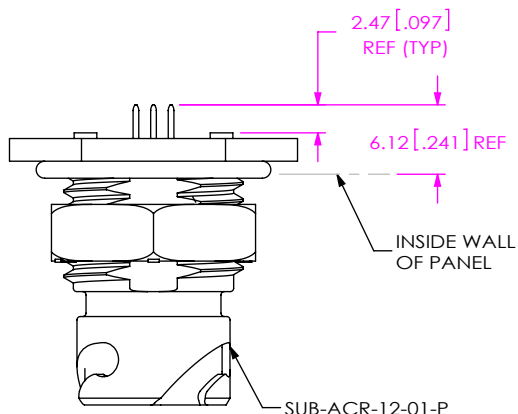

CCRB-12-X-X-X-XX-P

SHELL SIZE

STYLE
-P: PLASTIC

LEAD STYLE
-1: 8 POS

TERMINATION
-B1: .062 BOARD MOUNT

PLATING SPECIFICATION
-L: 10µ" GOLD IN CONTACT AREA
BRIGHT ACID TIN ON TAIL

GENDER
-T: TERMINAL

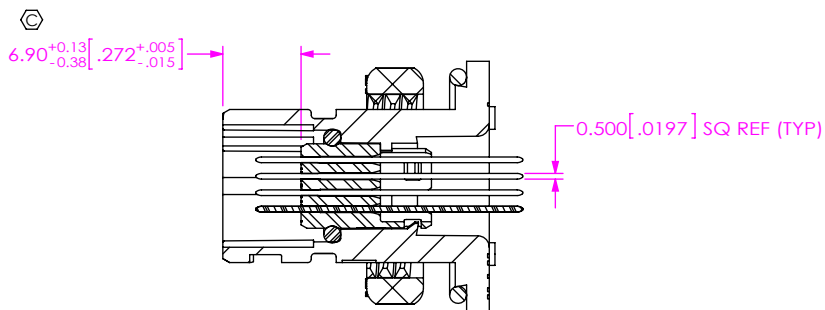
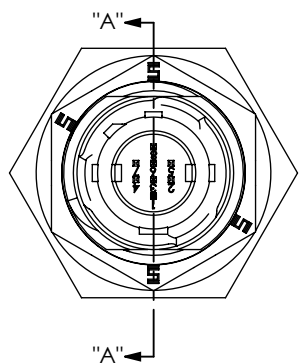
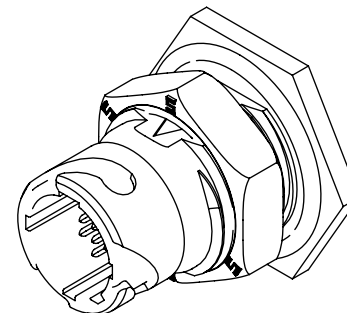

SECTION "A"- "A"

FIG 1
CCRB-12-1-L-T-B1-P SHOWN

NOTES:

1. © REPRESENTS A CRITICAL DIMENSION.
2. KIT COMPONENTS TO BE PACKAGED & SHIPPED IN TUBES.
3. REFER TO DCA-ACR-12-P-X PRINT FOR DUST CAP.
4. SEE CCR-12-XX-XX-X-XX-P FOR PANEL OPENING AND PANEL NUT TORQUE.

UNLESS OTHERWISE SPECIFIED, DIMENSIONS ARE IN MILLIMETERS.

TOLERANCES ARE:
DECIMALS ANGLES
X.X: ±0.3 [.01] 2°
X.XX: ±0.13 [.005]
X.XXX: ±0.051 [.0020]

PROPRIETARY NOTE

THIS DOCUMENT CONTAINS CONFIDENTIAL AND PROPRIETARY INFORMATION AND ALL DESIGN, MANUFACTURING, REPRODUCTION, USE, PATENT RIGHTS AND SALES RIGHTS ARE EXPRESSLY RESERVED BY SAMTEC, INC. THIS DOCUMENT SHALL NOT BE DISCLOSED, IN WHOLE OR PART, TO ANY UNAUTHORIZED PERSON OR ENTITY NOR REPRODUCED, TRANSFERRED OR INCORPORATED IN ANY OTHER PROJECT IN ANY MANNER WITHOUT THE EXPRESS WRITTEN CONSENT OF SAMTEC, INC.

MATERIAL: DO NOT SCALE DRAWING SHEET SCALE: 3:2
SHELL/NUT: NYLON, COLOR: BLACK
HOLDER BODY: PBT, COLOR: BLACK
O-RING: RUBBER
TERMINALS: PHOS BRONZE



520 PARK EAST BLVD, NEW ALBANY, IN 47150
PHONE: 812-944-6733 FAX: 812-948-5047
e-Mail: info@SAMTEC.com code 55322

DESCRIPTION:
ACCLIMATE CRIMP FIELD TERM. KIT

DWG. NO.
CCRB-12-X-X-X-XX-P

BY: JESSIE W 3/3/2014 SHEET 1 OF 2

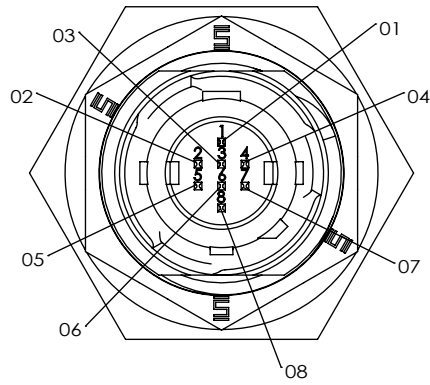

-T END OPTIONS
-1: 8 POS
SQUARE 0.5 TERMINALS

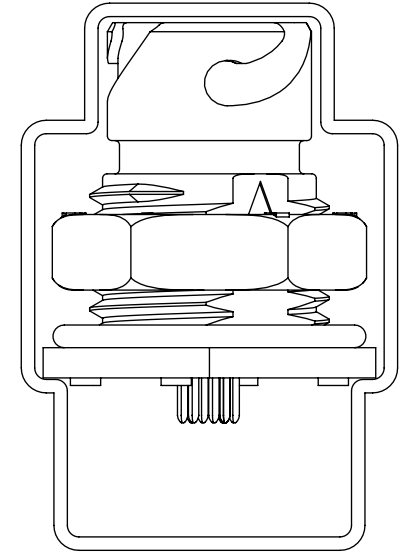

PACKAGING VIEW
TUBE: PT-ACR12
PLUG: TP-50

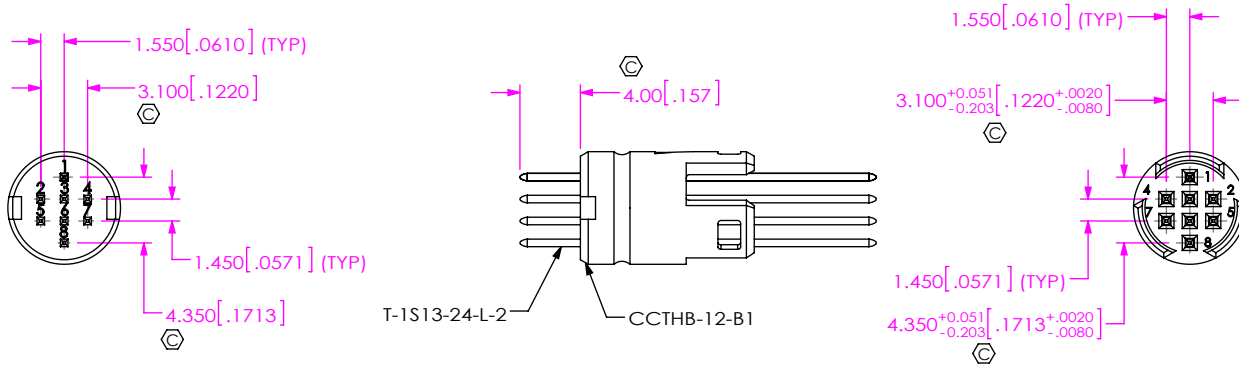

IN-PROCESS 1
FILL HOLDER BODY WITH PINS

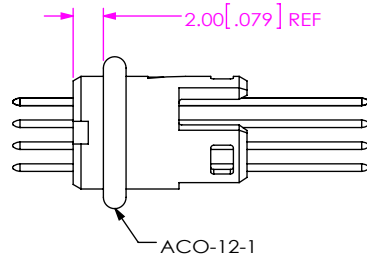
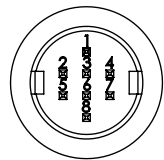

IN-PROCESS 2
ADD O-RING TO HOLDER BODY

PROPRIETARY NOTE
THIS DOCUMENT CONTAINS CONFIDENTIAL AND PROPRIETARY INFORMATION AND ALL DESIGN, MANUFACTURING, REPRODUCTION, USE, PATENT RIGHTS AND SALES RIGHTS ARE EXPRESSLY RESERVED BY SAMTEC, INC. THIS DOCUMENT SHALL NOT BE DISCLOSED, IN WHOLE OR PART, TO ANY UNAUTHORIZED PERSON OR ENTITY NOR REPRODUCED, TRANSFERRED OR INCORPORATED IN ANY OTHER PROJECT IN ANY MANNER WITHOUT THE EXPRESS WRITTEN CONSENT OF SAMTEC, INC.



520 PARK EAST BLVD, NEW ALBANY, IN 47150
PHONE: 812-944-6733 FAX: 812-948-5047
e-Mail info@SAMTEC.com code 55322

DO NOT SCALE DRAWING

SHEET SCALE: 2:1

DESCRIPTION:
ACCLIMATE CRIMP FIELD TERM. KIT

DWG. NO.
CCRB-12-X-X-X-XX-P

BY: JESSIE W 3/3/2014 SHEET 2 OF 2