

PRODUCT NUMBER
SEE PART NO. SCHEME

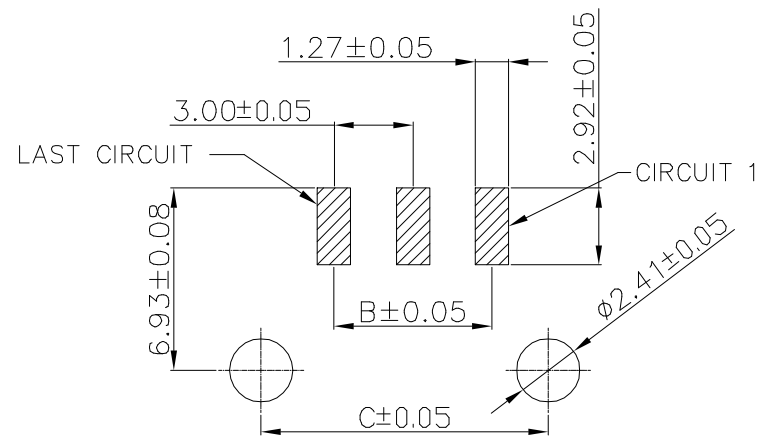
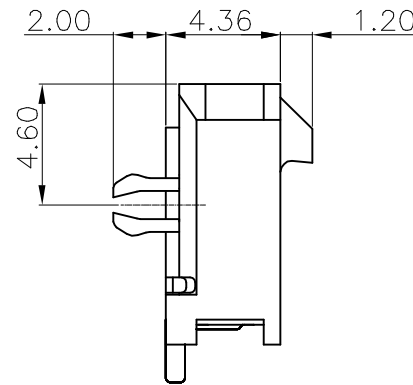
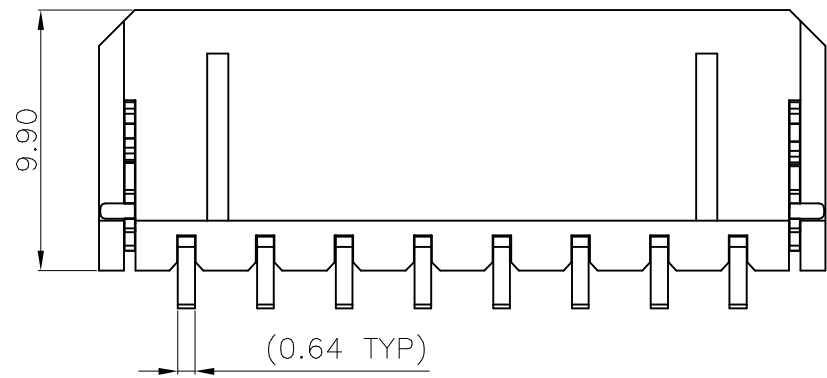
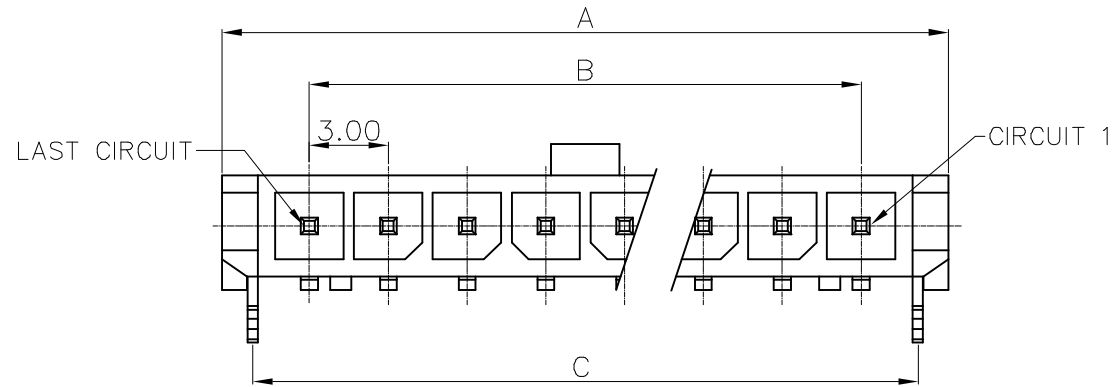

RECOMMENDED PAB LAYOUT
PCB THICKNESS=1.6mm. TOLERANCE:±0.05

NOTE:

- MATERIAL:
HOUSING: LCP, UL94V-0, HALOGEN FREE, COLOR: BLACK
CONTACT: COPPER ALLOY.
METAL HOLD DOWN: COPPER ALLOY
- CONTACT FINISH: NICKEL 50u" Min. UNDERPLATED OVERALL.
OPTIONAL PLATING ON CONTACT AREA, 100u" MIN MATTE TIN ON SOLDER TAIL.
METAL HOLD DOWN FINISH: 100u" MIN MATTE TIN OVER 50u" Min. NICKEL
- REFER GS-20-0399 APPLICATION SPECIFICATION FOR MATING CONNECTOR.
- PRODUCT SPECIFICATION: GS-12-1177.
- TAPE & REEL PACKAGE SPECIFICATION: GS-14-2359.
- APPLICATION SPECIFICATION: GS-20-0399
- THE HOUSING WILL WITHSTAND EXPOSURE TO 260°C PEAK TEMPERATURE FOR 10 SECONDS IN A REFLOW OVEN.
- LEAD FREE PRODUCTS MEET EUROPEAN UNION DIRECTIVES AND OTHER COUNTRY REGULATIONS AS DESCRIBED IN GS-47-0004
- PART NUMBER SCHEME:
10137867- XX X X LF
POS. CODE: ————
02: 2 POS
03: 4 POS
12: 12 POS
S1: SEE SHEET-2
LEAD FREE
GLOW WIRE COMPATIBLE:
1: COMPATIBLE
2: NON-COMPATIBLE
PLATING CODE:
1: 100u" Min. MATTE TIN OVERALL
2: GOLD FLASH ON CONTACT AREA,
100u"Min MATTE TIN ON TAIL
3: 15u"Min Au ON CONTACT AREA,
100u"Min MATTE TIN ON TAIL
4: 30u" Au ON CONTACT AREA,
100u"Min MATTE TIN ON TAIL

PART NUMBER	POS.	A	B	C
10137867-02XXLF	02	9.65	3.0	7.3
10137867-03XXLF	03	12.65	6.0	10.3
10137867-04XXLF	04	15.65	9.0	13.3
10137867-05XXLF	05	18.65	12.0	16.3
10137867-06XXLF	06	21.65	15.0	19.3
10137867-07XXLF	07	24.65	18.0	22.3
10137867-08XXLF	08	27.65	21.0	25.3
10137867-09XXLF	09	30.65	24.0	28.3
10137867-10XXLF	10	33.65	27.0	31.3
10137867-11XXLF	11	36.65	30.0	34.3
10137867-12XXLF	12	39.65	33.0	37.3

mat'l. code		surface ISO 1302 ✓		tolerance ISO 406 ISO 1101		projection		product family MINITEK PWR3.0	
ltr	ecn no	dr	date	tolerances unless otherwise specified		mm		title	
A		TAI	2015-11-25	angles	.0±.30	mm		MINITEK PWR3.0 R/A HEADER, SINGLE	
B	ELX-I-43460	AKHIL	2022-01-21	linear	.00±.20	scale N.T.S		ROW, SMT TAILS AND DIP BOARD LOCK	
				0'±x'	.000±0			dwg no sheet 1 of 2 size	
				dr	KENNY TAI	2015-11-25	Amphenol FCI		10137867 A3
				eng	AKHIL RAJAN	2022-01-21			
				chr	MITHUN PAUL	2022-01-21			
				appd	SPK	2022-01-21			type Product Customer Drawing
sheet index	revision sheet	B	B						
		1	2						

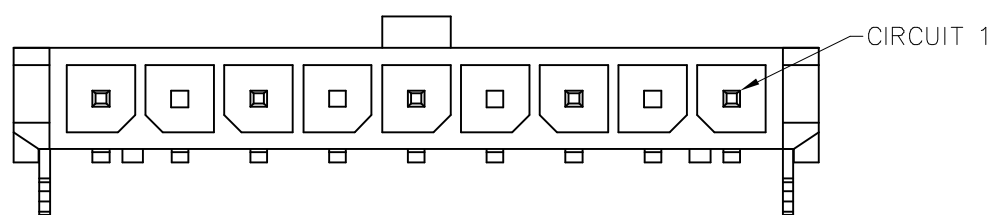
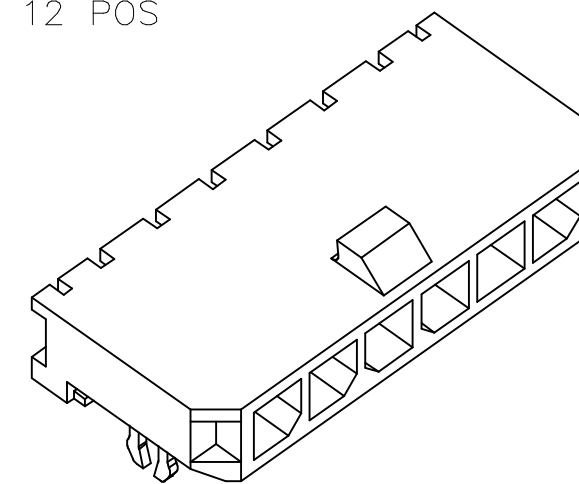
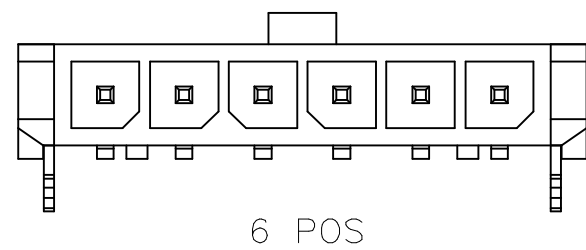
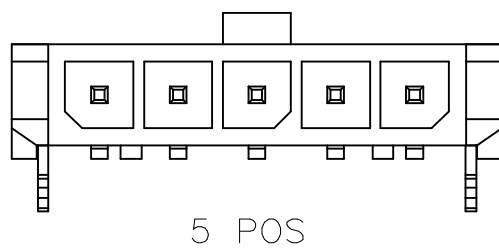
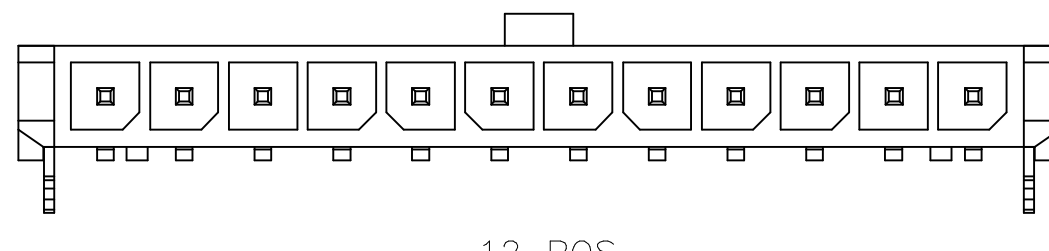
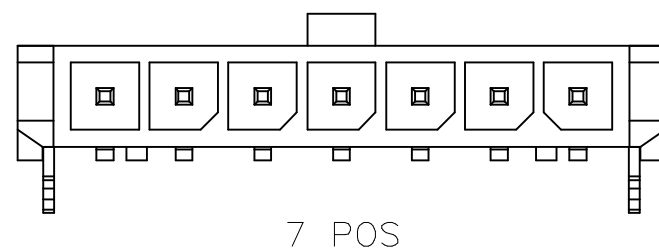
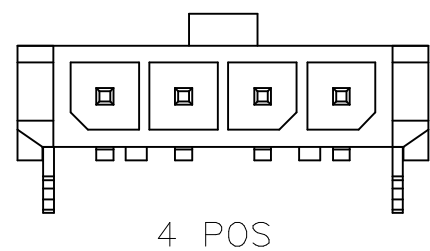
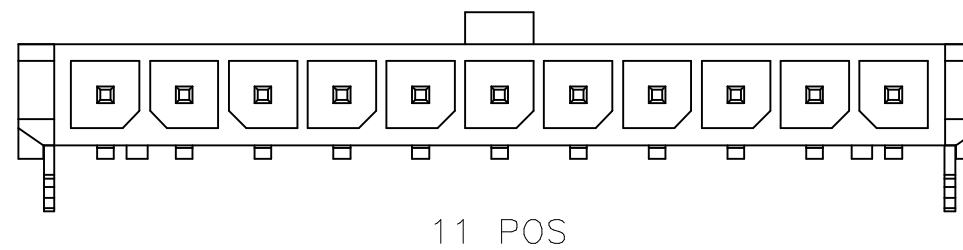
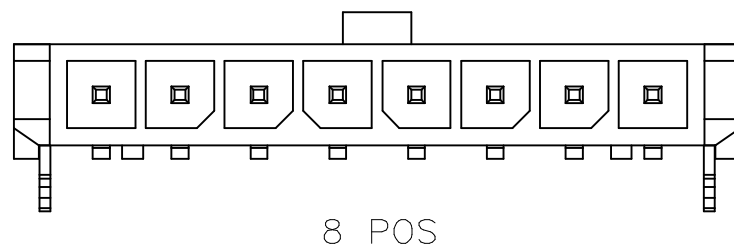
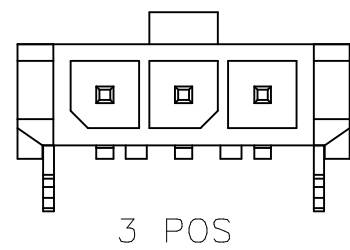
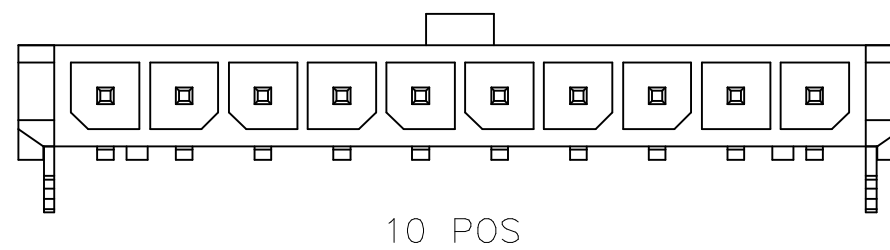
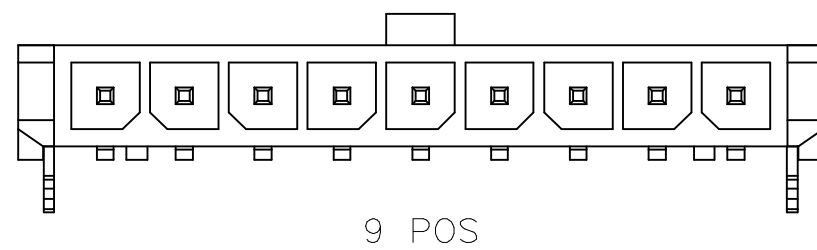
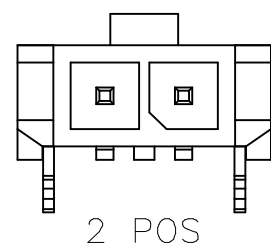

S1 : 9 Pos (CIRCUIT 2,4,6&8 REMOVED)

mat'l. code		surface ISO 1302 ✓		tolerance ISO 406 ISO 1101		projection mm		product family MINITEK PWR3.0		
ltr	ecn no	dr	date	tolerances unless otherwise specified		mm		title MINITEK PWR3.0 R/A HEADER, SINGLE ROW, SMT TAILS AND DIP BOARD LOCK		
				angles	linear	mm		dwg no 10137867		
				0°±x'		scale N.T.S		sheet 2 of 2 size A3		
				dr	KENNY TAI	2015-11-25			type Product Customer Drawing	
				eng	AKHIL RAJAN	2022-01-21				
				chr	MITHUN PAUL	2022-01-21				
				appd	SPK	2022-01-21				
sheet index	revision sheet	B 1	B 2							