

**NOTES:**

1. RECOMMENDED SOLDER INSTRUCTION SEE SHEET 2
2. METALSHELLS: COPPER ALLOY; min. 320µin TIN over 40-80µin NICKEL
3. INSULATORS: HIGH TEMPERATURE PLASTIC UL 94 V-0, BLACK
4. SIGNAL CONTACTS: COPPER ALLOY; PLATING (SEE PART NO):
  - PLEASE ADD C for 30µin HARD GOLD over min. 50µin NICKEL
  - PLEASE ADD B for 20µin HARD GOLD over min. 50µin NICKEL
  - PLEASE ADD A for GOLD FLASH over NICKEL (PREFERRED TYPE)
 SOLDER CUP ACCEPTS CABLE AWG 26
5. THREADED INSERTS: COPPER ALLOY; min 200µin TIN over 80µin NICKEL
6. FRAME: ZINC DIE CAST; NICKEL PLATED
7. RUBBER-GASKET: TPE; BLACK
8. COLLARS: COPPER ALLOY; min 200µin TIN over 80µin NICKEL
9. HEXLOCKING SCREW: STAINLESS STEEL
10. O-RING: SILICON; BLUE
11. SEALING COMPOUND: PUR; BLUE
12. CAPACITANCE: 370pF± 20%
13. DIELECTRIC WITHSTANDING VOLTAGE: 424 VDC
14. RECOMMENDED PANEL CUT-OUT on SHEET 2
15. RECOMMENDED TORQUE FOR MOUNTING SCREW 35N cm (3.1 in.LB) / max. 40N cm (3,5 in. LB)
16. CONNECTOR IS PART MARKED: **6STF09P□M03B30X CONEC ABC** (see note 4)

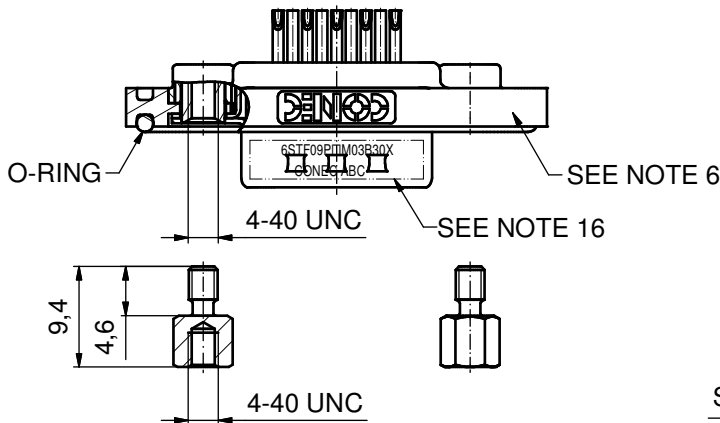
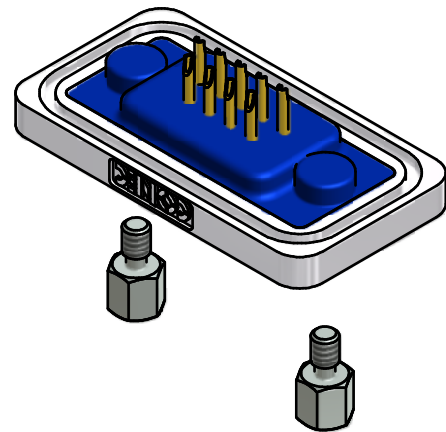
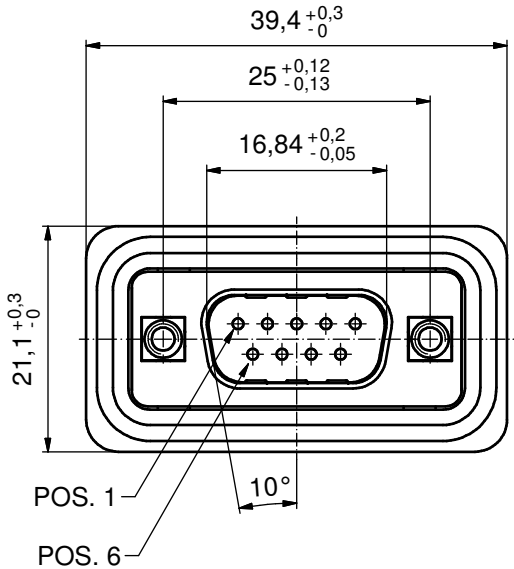
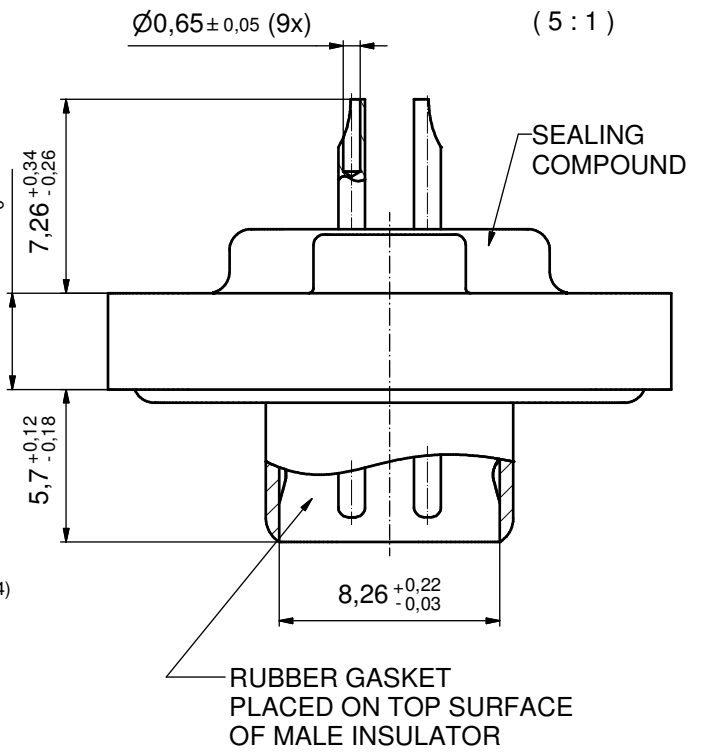

FILTER IS TOTALLY GUARDED AGAINST HUMIDITY. WATER COULD PENETRATE INTO THE MATING AREA. AT ALL TIMES WATER RESISTANT CONNECTORS NOT IN USE SHOULD BE COVERED WITH A CONEC WATER RESISTANT CAP OR WATER TIGHT HOOD.

Directive 2002/95/EC RoHS compliant

THIS DRAWING MAY NOT BE COPIED OR REPRODUCED IN ANY WAY, AND MAY NOT BE PASSED ON TO A THIRD PARTY WITHOUT WRITTEN PERMISSION. OWNERSHIP AND COPYRIGHT OF CONEC GmbH DO NOT ALTER CAD DRAWING BY HAND	tolerance		dim. in mm		scale:	2:1 (5:1)		
					material:	SEE NOTES		
			date	name		title:		
			drawn	25.09.12	Henneboel		<b>D-SUB FILTER MALE</b> 9pos. SOLDER CUP with threaded insert and hexlocking screw	
			appd.	26.09.12	Fischer			
			norm					
			d-old					
					dwg no:		DIN-A3	
					15K1A1164		sh: 1/2	
					part no: 6STF09P□M03B30X (see note 4)			
rev.	description	date	name					
a	Original							

## Solder Instruction

1. Cable should be prepared for soldering. The cable/wires must be pretinned.
2. Insert cable/wire into solder cup.
3. Operate the soldering iron at 350°C, 50 Watt max. and use a pencil tip.
4. Put tip to wire in solder cup.
5. After 1 second bring in solder.
6. Heat for 3 seconds longer. Do not heat contact more than 4 seconds in total.
7. Remove soldering iron.
8. Wait until solder gets rigid again.
9. Do not solder adjacent contacts consecutively,  
alternate position within the connector to minimize heat build up.

## RECOMMENDED PANEL CUT-OUT

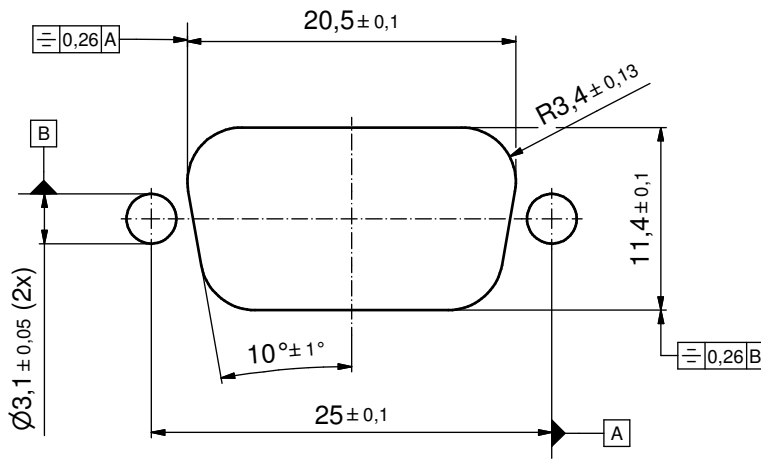

THIS DRAWING MAY NOT BE COPIED OR REPRODUCED IN ANY WAY, AND MAY NOT BE PASSED ON TO A THIRD PARTY WITHOUT WRITTEN PERMISSION. OWNERSHIP AND COPYRIGHT OF CONEC GmbH  DO NOT ALTER CAD DRAWING BY HAND				tolerance		scale: 3:1
				date	name	material:
				drawn	25.09.12	Henneboel
				appd.	26.09.12	Fischer
				norm		
				d-old		
				title:		
rev.	description	date	<b>RECOMMENDED PANEL CUT-OUT</b> D-SUB MALE 9pos. SOLDER CUP with threaded insert and hexlocking screw			
a	Original		dwg no: 15K1A1164 part no: SEE SHEET 1			
			DIN-A3 sh: 2/2			