

DO NOT
SCALE FROM
THIS PRINT

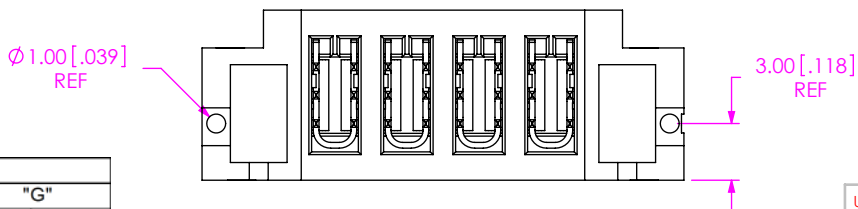
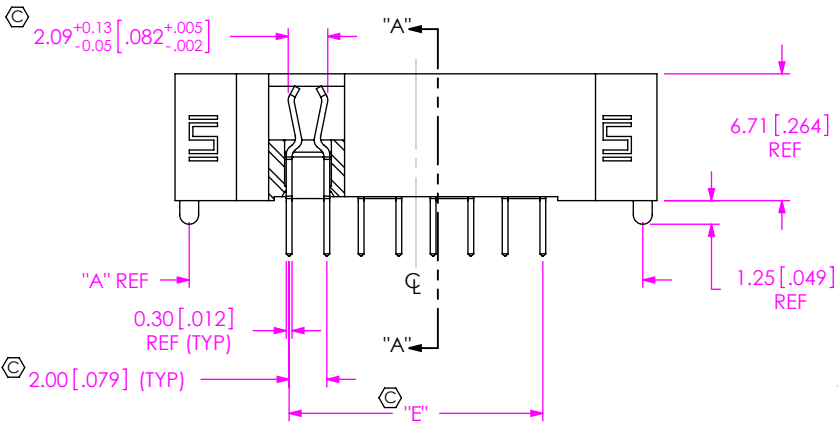
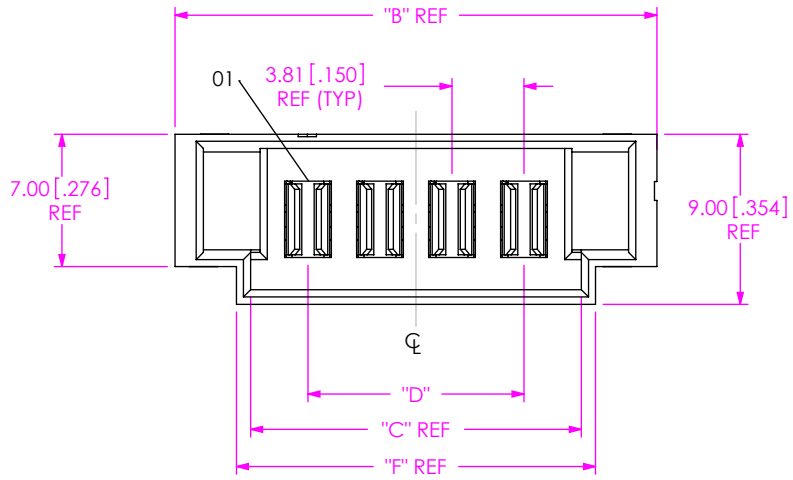

FIG 1
(UPT-04-03.0-01-X-V SHOWN)

TABLE 2

TAIL LENGTH	"G"
-01	2.79 [.110]
-02	3.54 [.139]
-03	2.33 [.092]

TABLE 1

PART NUMBER	"A"	"B"	"C"	"D"	"E"	"F"
UPT-02-03.0-XX-X-V-XX	16.38 [.645]	17.88 [.704]	9.88 [.389]	3.81 [.150]	5.82 [.229]	11.38 [.448]
UPT-04-03.0-XX-X-V-XX	24.00 [.945]	25.50 [1.004]	17.50 [.689]	11.43 [.450]	13.44 [.529]	19.00 [.748]
UPT-06-03.0-XX-X-V-XX	31.62 [1.245]	33.12 [1.304]	25.12 [.989]	19.05 [.750]	21.06 [.829]	26.62 [1.048]
UPT-08-03.0-XX-X-V-XX	39.24 [1.545]	40.74 [1.604]	32.74 [1.289]	26.67 [1.050]	28.68 [1.129]	34.24 [1.348]

UPT-XX-XX.X-XX-X-XX-XX-XX

No. OF POSITIONS
 -02: 2 POSITIONS
 -04: 4 POSITIONS
 -06: 6 POSITIONS
 -08: 8 POSITIONS

HEIGHT
 -03.0

OPTION
 TAPE & REEL

OPTION
 -LC: LOCKING CLIP
 (AVAILABLE WITH -V OPTION ONLY)

TAIL OPTION
 -V: VERTICAL
 -PV: PRESS FIT VERTICAL
 (ONLY AVAILABLE ON -03 TAIL LENGTH)

PLATING
 -L: 10 μ" LIGHT SELECTIVE GOLD IN CONTACT
 AREA, MATTE TIN ON TAIL
 -T: MATTE TIN CONTACT AND TAIL
 (ONLY AVAILABLE ON -PV)

TAIL LENGTH
 -01: FOR 1.57 [.062] THICK PCB (SEE FIG 1)
 (USE SUB-T-1M67-XX.X-01-X)
 -02: FOR 2.36 [.093] THICK PCB (SEE FIG 2)
 (USE SUB-T-1M67-XX.X-02-X)
 -03: PRESS-FIT FOR 1.57 [.062] THICK PCB AND UP
 (USE SUB-T-1M95-XX.X-X) (SEE FIG 3)
 (SEE NOTE 7)

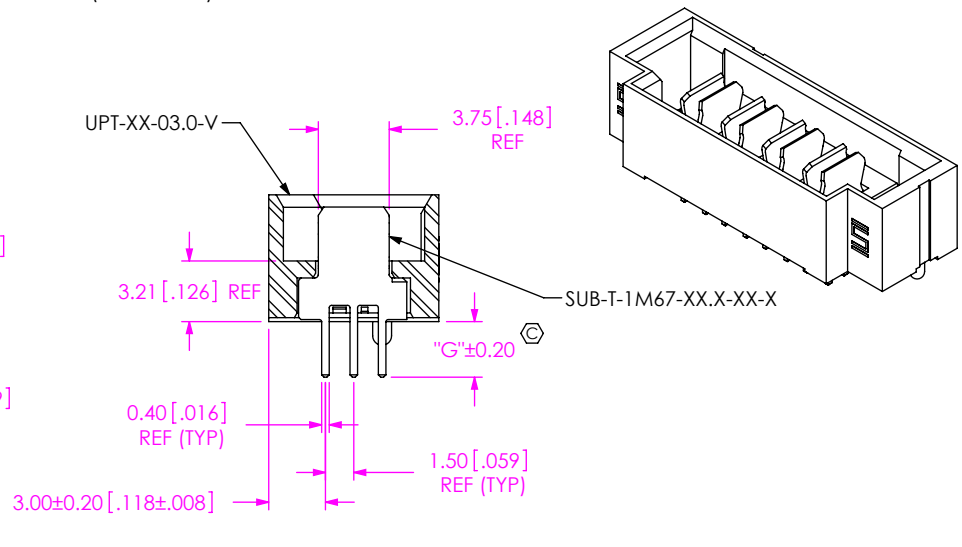

SECTION "A"-"A" NOTES:

- ⊗ REPRESENTS A CRITICAL DIMENSION.
- BURR ALLOWANCE: 0.038 [.0015] MAX.
- MINIMUM PUSHOUT FORCE: 4.45N [1.0 LB].
- MAXIMUM BOW: 0.15 [.006].
- MINIMUM -LC PULL OUT FORCE: 2.23 N [0.5 LB]
- PARTS TO BE PACKAGED IN TUBES UNLESS OTHERWISE STATED.
- APPLICATION TOOLING REQUIRED FOR PV TAIL LENGTH CONTACT IPG.

UNLESS OTHERWISE SPECIFIED,
DIMENSIONS ARE IN MILLIMETERS.

TOLERANCES ARE:

DECIMALS	ANGLES
X.X: ±0.3 [.01]	2°
X.XX: ±0.13 [.005]	
X.XXX: ±0.051 [.0020]	

PROPRIETARY NOTE

THIS DOCUMENT CONTAINS CONFIDENTIAL AND PROPRIETARY INFORMATION AND ALL DESIGN, MANUFACTURING, REPRODUCTION, USE, PATENT RIGHTS AND SALES RIGHTS ARE EXPRESSLY RESERVED BY SAMTEC, INC. THIS DOCUMENT SHALL NOT BE DISCLOSED, IN WHOLE OR PART, TO ANY UNAUTHORIZED PERSON OR ENTITY NOR REPRODUCED, TRANSFERRED OR INCORPORATED IN ANY OTHER PROJECT IN ANY MANNER WITHOUT THE EXPRESS WRITTEN CONSENT OF SAMTEC, INC.

MATERIAL: DO NOT SCALE DRAWING SHEET SCALE: 1:0.4
 INSULATOR: LCP, COLOR: BLACK UV 94 VO
 TERMINAL: BeCu
 LOCKING CLIP: PHOS BRONZE



520 PARK EAST BLVD, NEW ALBANY, IN 47150
 PHONE: 812-944-6733 FAX: 812-948-5047
 e-Mail: info@SAMTEC.com code: 55322

DESCRIPTION: UPT-V, ASSEMBLY

DWG. NO. UPT-XX-XX.X-XX-X-XX-XX-XX

BY: B RAY 08/21/2008 SHEET 1 OF 2

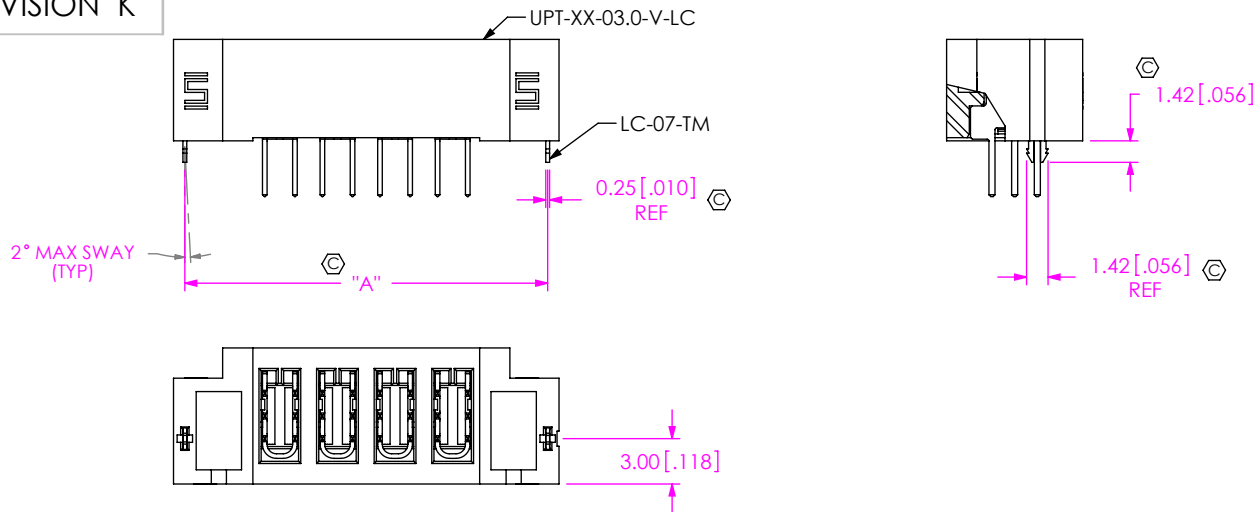

FIG 2
(UPT-04-03.0-02-X-V-LC SHOWN)
(SAME AS FIG 1, DIFFERENT AS SHOWN)

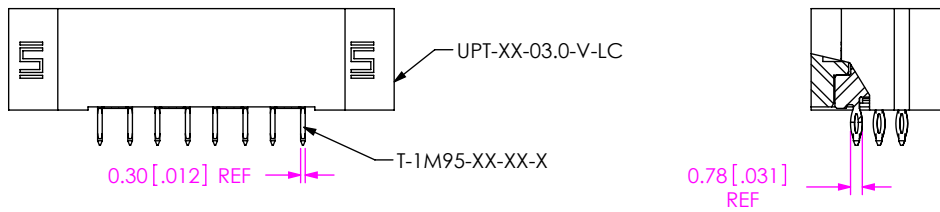
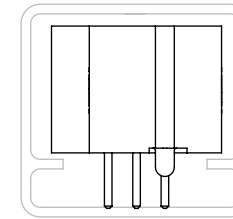
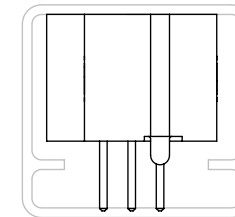

FIG 3
(UPT-04-03-X-PV SHOWN)
(SAME AS FIG 1, DIFFERENT AS SHOWN)



-01 TAIL LENGTH



-02 TAIL LENGTH

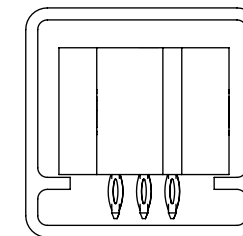

-03 TAIL LENGTH

PACKAGING TUBE VIEW

TUBE TABLE		
TAIL LENGTH	TUBE	PLUG
-01	PT-YFW-07F-P	TP-29
-02	PT-YFW-07F-P	TP-29
-03	PT-YFW-07F-P	TP-29

TABLE 3		
PLATING	POWER PIN CONTACT AREA	POWER PIN TAIL
-L	LIGHT GOLD	MATTE TIN
-T	MATTE TIN	MATTE TIN

PROPRIETARY NOTE
THIS DOCUMENT CONTAINS CONFIDENTIAL AND PROPRIETARY INFORMATION AND ALL DESIGN, MANUFACTURING, REPRODUCTION, USE, PATENT RIGHTS AND SALES RIGHTS ARE EXPRESSLY RESERVED BY SAMTEC, INC. THIS DOCUMENT SHALL NOT BE DISCLOSED, IN WHOLE OR PART, TO ANY UNAUTHORIZED PERSON OR ENTITY NOR REPRODUCED, TRANSFERRED OR INCORPORATED IN ANY OTHER PROJECT IN ANY MANNER WITHOUT THE EXPRESS WRITTEN CONSENT OF SAMTEC, INC.



520 PARK EAST BLVD. NEW ALBANY, IN 47150
PHONE: 812-944-6733 FAX: 812-948-5047
e-Mail: info@SAMTEC.com code: 55322

DO NOT SCALE DRAWING

SHEET SCALE: 3:1

DESCRIPTION:

UPT-V, ASSEMBLY

DWG. NO.

UPT-XX-XX.X-XX-X-XX-XX-XX

BY: B RAY

08/21/2008

SHEET 2 OF 2