

Stellaris® LM3S9D90 Evaluation Kit User's Manual

User's Manual



Copyright

Copyright © 2011 Texas Instruments, Inc. All rights reserved. Stellaris and StellarisWare are registered trademarks of Texas Instruments. ARM and Thumb are registered trademarks, and Cortex is a trademark of ARM Limited. Other names and brands may be claimed as the property of others.

Texas Instruments
108 Wild Basin, Suite 350
Austin, TX 78746
<http://www.ti.com/stellaris>



Table of Contents

Chapter 1: Stellaris® LM3S9D90 Evaluation Kit Overview	7
Kit Contents	8
Using the EK-LM3S9D90.....	8
Features.....	8
Chapter 2: Hardware Description.....	11
Evaluation Board	11
Functional Description	11
In-Circuit Debug Interface Board	14
Functional Description	14
Chapter 3: Software Development	17
Software Description.....	17
Source Code	17
Tool Options	17
Programming the EK-LM3S9D90 Board.....	17
Appendix A: Schematics.....	19
Appendix B: Connection Details	25
Component Locations	25
Board Dimensions	26
Board Connectivity.....	27
References	27
Appendix C: Microcontroller GPIO Assignments.....	29

List of Figures

Figure 1-1. LM3S9D90 Evaluation Board	7
Figure 1-2. In-Circuit Debug Interface Board.....	7
Figure 2-1. EK-LM3S9D90 Evaluation Board Block Diagram.....	11
Figure 2-2. GPIO Pads	12
Figure 2-3. JTAG/SWD Connector	12
Figure 2-4. PWR/UART Connector.....	13
Figure 2-5. In Circuit Debug (ICDI) Board Block Diagram	14
Figure 2-6. JTAG/SWD Connector J1	15
Figure 2-7. JTAG/SWD Connector J3	15
Figure 2-8. PWR/UART Connector.....	15
Figure B-1. EK-LM3S9D90 Evaluation Board Component Locations	25
Figure B-2. BD-ICDI Board Component Locations	25
Figure B-3. EK-LM3S9D90 Evaluation Board Dimensions	26
Figure B-4. In-Circuit Debug Interface Board Dimensions	26
Figure B-5. ICDI – EK-LM3S9D90 Board Connectivity	27

List of Tables

Table C-1. EK-LM3S9D90 Evaluation Board GPIO Usage.....	29
---	----

Stellaris® LM3S9D90 Evaluation Kit Overview

Texas Instruments' Stellaris® LM3S9D90 Evaluation Board Kit (EK-LM3S9D90) is a low-cost platform for evaluation of the LM3S9D90 microcontroller. The kit includes two boards, the EK-LM3S9D90 evaluation board, and the In-Circuit Debug Interface (BD-ICDI) board.

The EK-LM3S9D90 board includes the LM3S9D90 ARM® Cortex™-M3 Microcontroller, a 10/100 Mbit Ethernet port, a full-speed USB-OTG port, connectors for interface to the BD-ICDI board, and oversized pads for easy connection to the microcontroller GPIO ports.

The BD-ICDI board is a USB full-speed JTAG/SWD debugger board. It includes a USB miniB connector for connection to a USB PC port, and two shrouded header connectors for connection to the EK-LM3S9D90 board.

Development of software for the EK-LM3S9D90 is simplified by using Texas Instruments' comprehensive StellarisWare® peripheral driver library and ARM development tools from our tools partners. The Stellaris® LM3S9D90 Evaluation Board Kit includes the two boards described, a documentation CD, and cables. All design files are provided on the EK-LM3S9D90 CD.

Figure 1-1. LM3S9D90 Evaluation Board



Figure 1-2. In-Circuit Debug Interface Board

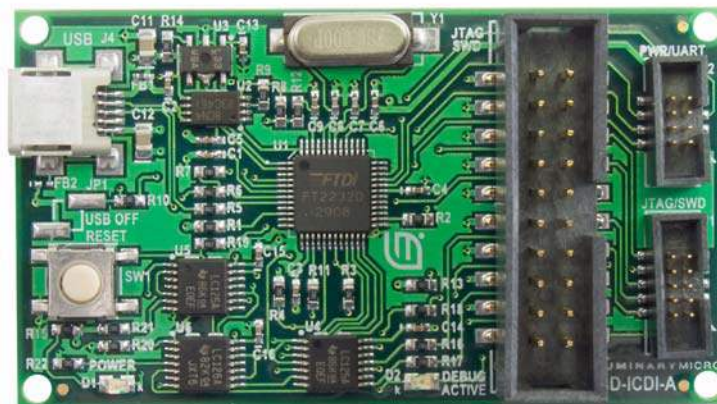

Kit Contents

The EK-LM3S9D90 evaluation kit comes with the following:

- EK-LM3S9D90 evaluation board
- In-Circuit Debug Interface (BD-ICDI) board
 - Connects to USB port on PC and to 10-pin, fine-pitch ARM JTAG connector on the EK-LM3S9D90 evaluation board
 - Secondary 8-pin Power/UART connector provides power and virtual comm-port capability to the EK-LM3S9D90 evaluation board.
- Cables
 - USB miniB to USB-A cable
 - USB-OTG to USB-A cable
 - 10-pin ribbon cable for JTAG/SWD connection
 - 8-pin ribbon cable for Power/UART connection
- CD containing:
 - A supported version of one of the following (including a toolchain-specific Quickstart guide):
 - Keil™ RealView® Microcontroller Development Kit (MDK-ARM)
 - IAR Embedded Workbench
 - Sourcery CodeBench development tools
 - Code Red Technologies development tools
 - Texas Instruments' Code Composer Studio™ IDE
 - Complete documentation
 - Quickstart application source code
 - Stellaris® Firmware Development Package with example source code

Using the EK-LM3S9D90

The recommended steps for using the EK-LM3S9D90 evaluation kit are:

1. **Follow the Quickstart guide included in the kit.** The Quickstart guide will help get the EK-LM3S9D90 Evaluation Board up and running in minutes.
2. **Use your preferred ARM tool-chain and the Stellaris Peripheral Driver Library to develop an application.** Software applications are loaded using the BD-ICDI board. See Chapter 3, “Software Development,” for the programming procedure. The *StellarisWare Peripheral Driver Library Software Reference Manual* contains specific information on software structure and function.
3. **Customize and integrate the hardware to suit an end application.** This user's manual is an important reference for understanding circuit operation and completing hardware modification.

Features

The EK-LM3S9D90 evaluation kit provides the following features:

- LM3S9D90 high-performance Stellaris microcontroller and large memory
 - 32-bit ARM® Cortex™-M3 core
 - 512 KB single-cycle Flash memory, 96 KB single-cycle SRAM
- Ethernet 10/100 port with two LED indicators
- USB 2.0 Full-Speed OTG port
- Virtual serial communications port capability
- Oversized board pads for GPIO access
- User pushbutton and LED
- Detachable ICDI board can be used for debugging other Stellaris boards
- Easy to customize
 - Includes full source code, example applications, and design files
 - Develop using tools supporting FastMATH from Keil, IAR, Code Sourcery, and Code Red (using a Stellaris evaluation kit or preferred ARM Cortex-M3 debugger)
 - Supported by Texas Instruments' StellarisWare peripheral driver library

Hardware Description

The EK-LM3S9D90 evaluation kit contains two boards: the EK-LM3S9D90 evaluation board and the BD-ICDI JTAG debug board as described in more detail in this chapter.

Evaluation Board

The EK-LM3S9D90 evaluation board uses the Stellaris® LM3S9D90 microcontroller and includes a 10/100 Ethernet port and a USB 2.0 full-speed OTG port. The board is intended for use with the ICDI board, but can be used as a standalone board as well. Figure 2-1 shows the block diagram.

Figure 2-1. EK-LM3S9D90 Evaluation Board Block Diagram

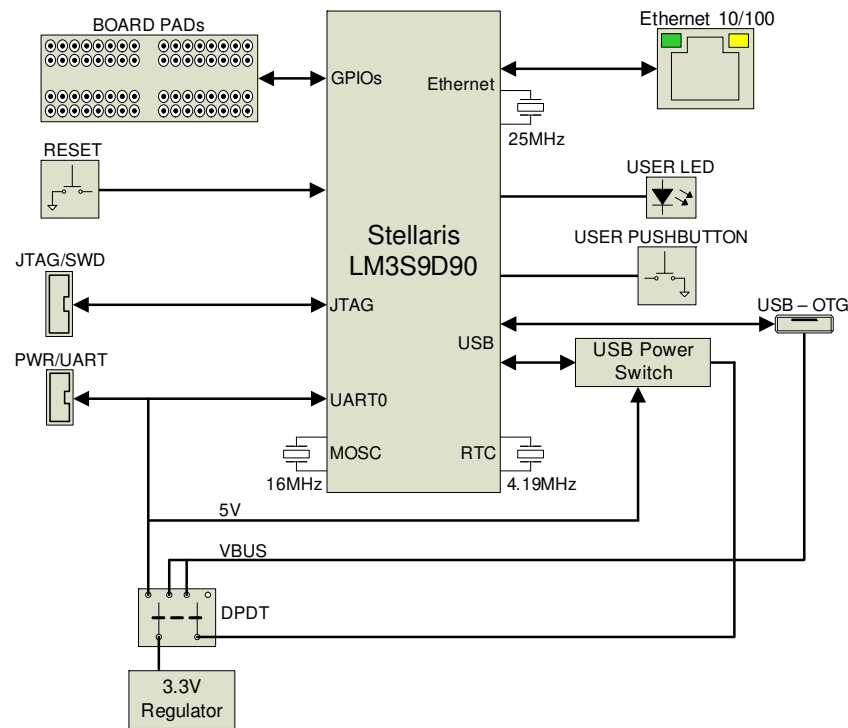

Functional Description

Microcontroller, Reset, GPIO Pads, and JTAG (Schematic page 20)

Microcontroller

The evaluation board uses the Stellaris LM3S9D90 microcontroller. A 16 MHz crystal provides the main oscillator clock which can directly drive the ARM core clock or can drive an internal PLL to increase the core clock up to 80 MHz. A 25 MHz crystal is used for the Ethernet clock and a 4.194304 MHz crystal is used for the real-time clock.

The LM3S9D90 microcontroller has an internal LDO voltage regulator that supplies power for internal use. This rail requires only three capacitors for decoupling and is not connected to any other circuits.

Reset

A reset switch and R-C network connects to the microcontroller’s RSTn input. The reset signal is also connected to the JTAG/SWD connector J1 to allow reset control from the debugger.

GPIO Pads

Four groups of oversized board pads with a 0.1” spacing provide access to GPIO signals and standard 0.1” pitch headers can be soldered to these pads. Pads are labeled with the corresponding GPIO signal, and pads with no labels are unconnected. Note that GPIO signals required for operation of the Ethernet port, USB port, and JTAG port are reserved for board use and are not available on these pads. Figure 2-2 shows the pad groups.

Figure 2-2. GPIO Pads

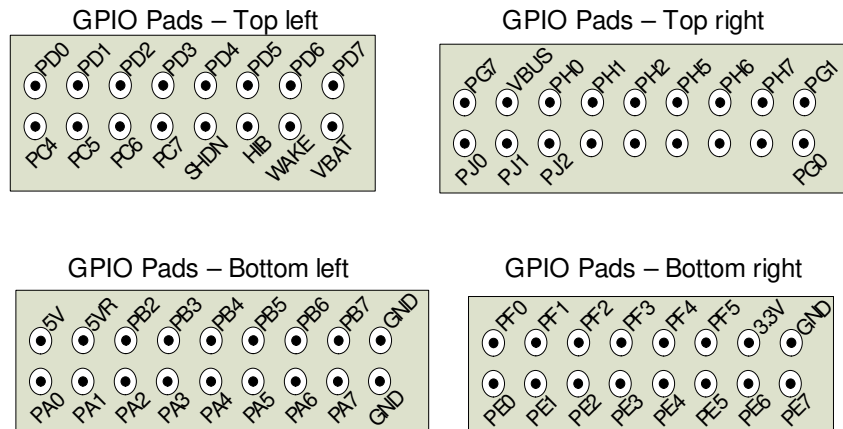

GPIO Jumpers

Some of the GPIO signals used by the board are connected to board jumpers and can be disconnected to provide additional user GPIOs. GPIOs PA0/PA1/PB4/PD0/PF2/PF3 are connected to jumpers JR1-JR6 respectively. Each signal can be freed by cutting the trace of the corresponding jumper (cut at white line on silkscreen). The jumper pads have the same footprint as an 0603 SMT resistor. To reconnect a previously cut jumper, solder a 0 ohm resistor to the corresponding jumper footprint.

JTAG/SWD

The JTAG/SWD connector J1 is used for program download and debug. This is a 2x5 fine pitch (0.050”) ARM JTAG connector, see (Figure 2-3) for signal definition. The LM3S9D90 microcontroller supports JTAG debug, Serial Wire Debug (SWD), and Serial Wire Out (SWO) trace with this connector. The ICD1 board connects via a 10-wire ribbon cable to this connector.

Figure 2-3. JTAG/SWD Connector

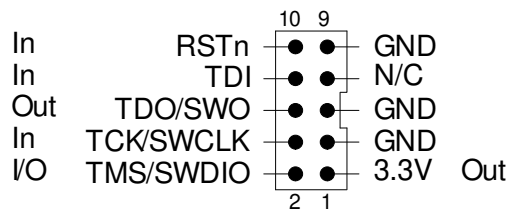

PWR/UART

The PWR/UART connector J2 is used to provide 5 V power from the ICD1 board and also to connect the LM3S9D90 UART0 signals. This is a 2x4 fine pitch (0.050") connector, see (Figure 2-4) for signal definition. The UART0 signals are connected to GPIO jumpers JR1 and JR2 and can be disconnected from connector J2 if required, see "GPIO Jumpers" on page 12. The ICD1 board connects via an 8-wire ribbon cable to this connector.

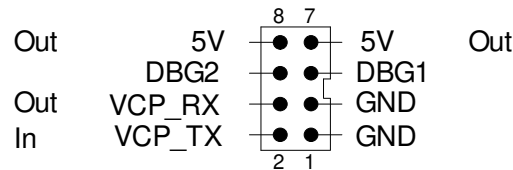
Figure 2-4. PWR/UART Connector**Ethernet, USB, Power and Miscellaneous (Schematic page 21)**

Page 2 of the schematics contains the Ethernet RJ45 connector, USB power switch and USB OTG connector, 3.3 V regulator, and power switch selector.

Ethernet Port

The on-board RJ45 connector provides a 10/100 base T Ethernet port. The RJ45 connector includes integrated LEDs and magnetics. The LEDs are connected to GPIO jumpers JR4 and JR5 and can be disconnected from the RJ45 connector if required, see GPIO Jumpers section.

USB Port

The on-board USB microAB connector provides a USB 2.0 full-speed port. To use as an On-The-Go (OTG) port, the power selector switch SW3 lever must be set to EXT. This selects an external 5 V power source to provide power to the board and the USB power switch. If the SW3 lever is set to USB, power to the board is received from USB, the on-board USB power switch output is disconnected from USB, and the board can only be used as a USB device. When using the USB-OTG port in Host mode, the current provided to a USB device should be limited to 100 mA or less when powered from the ICD1 board. If powered from the 5 V test pad, then this can be increased to 500 mA.

Board Power

The board requires 5 V for operation, and switch SW3 is used to select the power source. If the switch lever is moved towards the USB label on the board, power is received from the USB connector. If the switch lever is moved towards the EXTERNAL board label, the board is powered from the PWR/UART connector and the ICD1 board provides power to this connector. DC regulator U2 generates 3.3 V for powering the board circuits and includes power indicator LED D1.

User Devices

Pushbutton switch SW2 and LED D2 are available for the user and connected to PB4 and PD0 respectively. These GPIOs are connected to GPIO jumpers JR3 and JR4 and can be disconnected from SW2 and D2 if required, see GPIO Jumpers section.

In-Circuit Debug Interface Board

The ICDI board is used to download and debug programs on the EK-LM3S9D90 evaluation board, but can also be used for debug of other Stellaris boards. A block diagram is shown in Figure 2-5.

Figure 2-5. In Circuit Debug (ICDI) Board Block Diagram

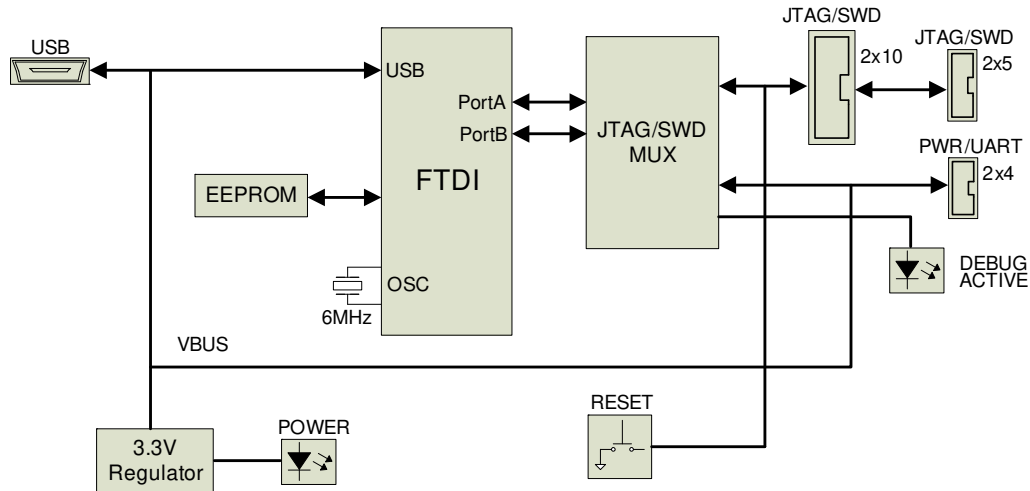

Functional Description

USB to JTAG/SWD, Power (Schematic page 22)

USB

An FTDI USB to serial protocol chip is used for the USB 2.0 full-speed device controller. This is connected to a USB miniB connector and to a set of buffers/multiplexers. A 1-kbit serial EEPROM contains USB configuration data which is read at power up.

Power

The board receives 5 V power from the USB bus. A DC regulator generates 3.3 V for on-board circuits, when on LED D1 (POWER) is lit on.

Headers

Three headers are on-board, a 10-pin JTAG/SWD header J1, an 8-pin PWR/UART header J2, and an optional 20-pin JTAG/SWD header J3. The 10-pin and 8-pin headers are used to connect to the EK-LM3S9D90 evaluation board.

JTAG/SWD

JTAG/SWD connector J1 connects to the EK-LM3S9D90 evaluation board with a ribbon cable for program download and debug. This is a 2x5 fine pitch (0.050") ARM JTAG connector, see (Figure 2-6) for signal definition. The ICDI supports JTAG debug, SWD (Serial Wire Debug), and SWO (Serial Wire Out) trace with this connector.

Optional JTAG/SWD connector J3 is a 2x10 standard pitch (0.1") ARM JTAG connector directly connected to J1, see (Figure 2-7) for signal definition. This allows the ICDI to connect to targets that use a 2x10 connector. It also allows the use of an external 2x10 debugger on targets with the fine pitch connector, including the EK-LM3S9D90. The signal direction shown for J1 and J3

applies when the ICDI is used as the JTAG/SWD debugger and LED D2 (DEBUG ACTIVE) is lit on. In this case only one of the two connectors J1/J3 should be used.

The ICDI can also be used as a 20-pin to 10-pin adapter for external JTAG debuggers. Note that the DEBUG ACTIVE LED must be off before connecting any external JTAG debuggers.

Figure 2-6. JTAG/SWD Connector J1

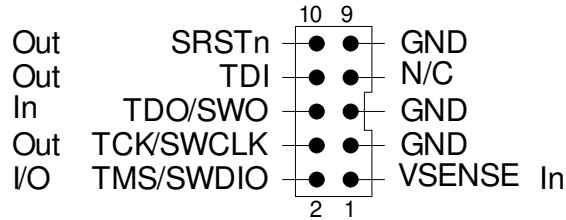
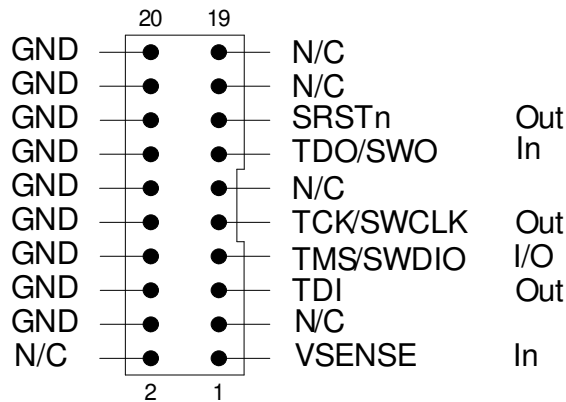

Figure 2-7. JTAG/SWD Connector J3



Pushbutton

Pushbutton SW1 (RESET) is provided to manually generate the SRSTn signal to the target device. The SRSTn signal can also be generated under program control.

PWR/UART

The PWR/UART connector J2 connects to the EK-LM3S9D90 evaluation board with a ribbon cable and provides 5 V power and a virtual communications port connection. This is a 2 x 4 fine pitch (0.050”) connector, see (Figure 2-8) for signal definition. Signals DBG1/DBG2 are reserved.

Figure 2-8. PWR/UART Connector

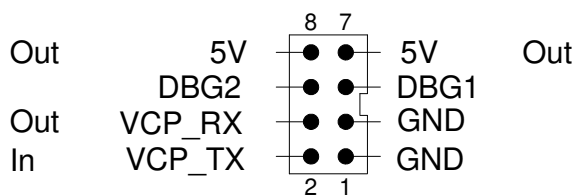

JTAG / SWD Multiplexer (Schematic page 23)

Buffers

A set of tri-state buffers is used to multiplex JTAG and SWD signals, and also multiplex the UART VCP_TX signal with the SWO signal. LED D2 (DEBUG ACTIVE) is lit on when these buffers are enabled. To avoid signal contention, external JTAG debuggers should not be connected when DEBUG ACTIVE is on.

Software Development

This chapter provides general information on software development as well as instructions for Flash memory programming.

Software Description

The software provided with the EK-LM3S9D90 provides access to all of the peripheral devices supplied in the design. The StellarisWare® Peripheral Driver Library is used to operate the on-chip peripherals.

The software includes a set of example applications that utilize the StellarisWare Peripheral Driver Library. These applications demonstrate the capabilities of the LM3S9D90 microcontroller, as well as providing a starting point for the development of the final application for use on the EK-LM3S9D90.

Source Code

The complete source code is included on the EK-LM3S9D90 CD. Refer to the Quickstart Guide for a detailed description of hardware setup and how to install the source code. The source code and binary files are installed in the DriverLib tree.

Tool Options

The source code installation includes directories containing projects and/or makefiles for the following tool-chains:

- Keil ARM RealView® Microcontroller Development System
- IAR Embedded Workbench for ARM
- CodeSourcery G++
- Code Red Technology Red Suite
- Generic Gnu C compiler

Evaluation versions of these tools may be downloaded from www.ti.com/stellaris. Due to code size restrictions, the evaluation tools may not build all example programs. A full license is necessary to re-build or debug all examples.

Instructions on installing and using each of the evaluation tools can be found in the Quickstart guides (for example, Quickstart-Keil, Quickstart-IAR) which are available for download from the evaluation kit section of our web site at www.ti.com/stellaris.

For detailed information on using the tools refer to the documentation included in the tool chain installation or visit the website of the tools supplier.

Programming the EK-LM3S9D90 Board

The EK-LM3S9D90 software package includes pre-built binaries for each of the example applications. If you installed DriverLib to the default installation path of C:/DriverLib, you can find the example applications in "C:/DriverLib/boards/ek-tempest". The ICD1 board is used along with Stellaris LM Flash Programmer tool to program applications on the EK-LM3S9D90 board.

To program example applications into the EK-LM3S9D90 evaluation board using the ICDI board:

1. Install LM Flash Programmer on a Windows PC.
2. Connect the 10-wire ribbon cable to the 10-pin header on the ICDI board and to the 10-pin header on the EK-LM3S9D90 board. The red stripe on the ribbon cable should be facing the bottom of the connectors (see Figure B-5 on page 27).
3. Connect the 8-wire ribbon cable to the 8-pin header on the ICDI board and to the 8-pin header on the EK-LM3S9D90 board. The red stripe on the ribbon cable should be facing the bottom of the connectors (see Figure B-5 on page 27).
4. Verify that slide switch SW3 on the EK-LM3S9D90 board is set to EXTERNAL.
5. Connect the USB cable A-plug to an available port on the PC and the miniB-plug to the ICDI board.
6. Verify that POWER LED D1 on the ICDI board is lit and POWER LED D1 on the EK-LM3S9D90 board is also lit.
7. Run LM Flash Programmer.
8. In the Configuration tab, use the Quick Set control to select LM3S9D90 Evaluation Board.
9. Move to the Program tab and click the Browse button. Navigate to the example applications directory (the default location is "C:/DriverLib/boards/ek-tempest/").
10. Each example application has its own directory. Navigate into the example directory that you want to load and then into the directory which contains the binary (*.bin) files. Select the binary file and click Open.
11. Set the "Erase Method" to "Erase Necessary Pages" and check the "Verify After Program" box.
12. Next, click the Program button to start the Erase, Download and Verify process. The DEBUG ACTIVE LED (D2) on the ICDI will turn on at this time.
13. Program execution will start once Verify is complete.

The EK-LM3S9D90 design uses a Stellaris® microcontroller to handle networking, USB-OTG, and peripheral functions. The entire circuit is built on a compact four-layer printed circuit board. All design files are provided on the EK-LM3S9D90 CD.

Schematics

This section contains the schematics for the EK-LM3S9D90 evaluation board and also the BD-ICDI debug board.

EK-LM3S9D90 Evaluation Board

- Microcontroller, Reset, and Headers on page 20
- Ethernet, USB, and Power on page 21

BD-ICDI Board

- USB to JTAG, SWD, Headers, and Power on page 22
- JTAG/SWD Multiplexer on page 23

Revision History

Revision	Date	Description
A	2/24/2009	First release for prototypes.
B	4/15/2009	Released to production.
C	1/21/2010	DC regulators U2 and U4 replaced for T1 parts.
	6/17/2011	Add option to install either LM3S9B90 or LM3S9D90

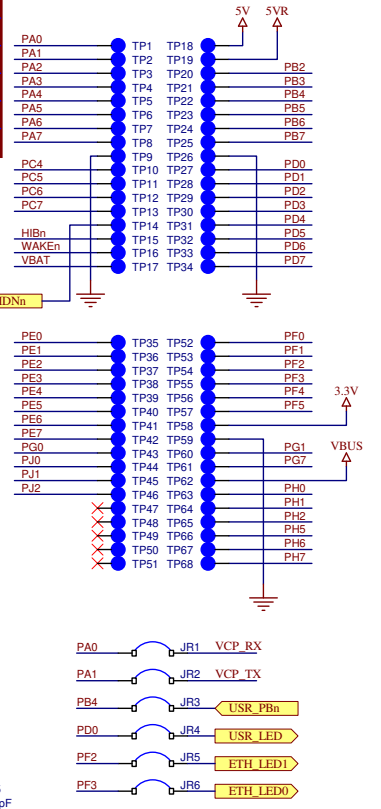
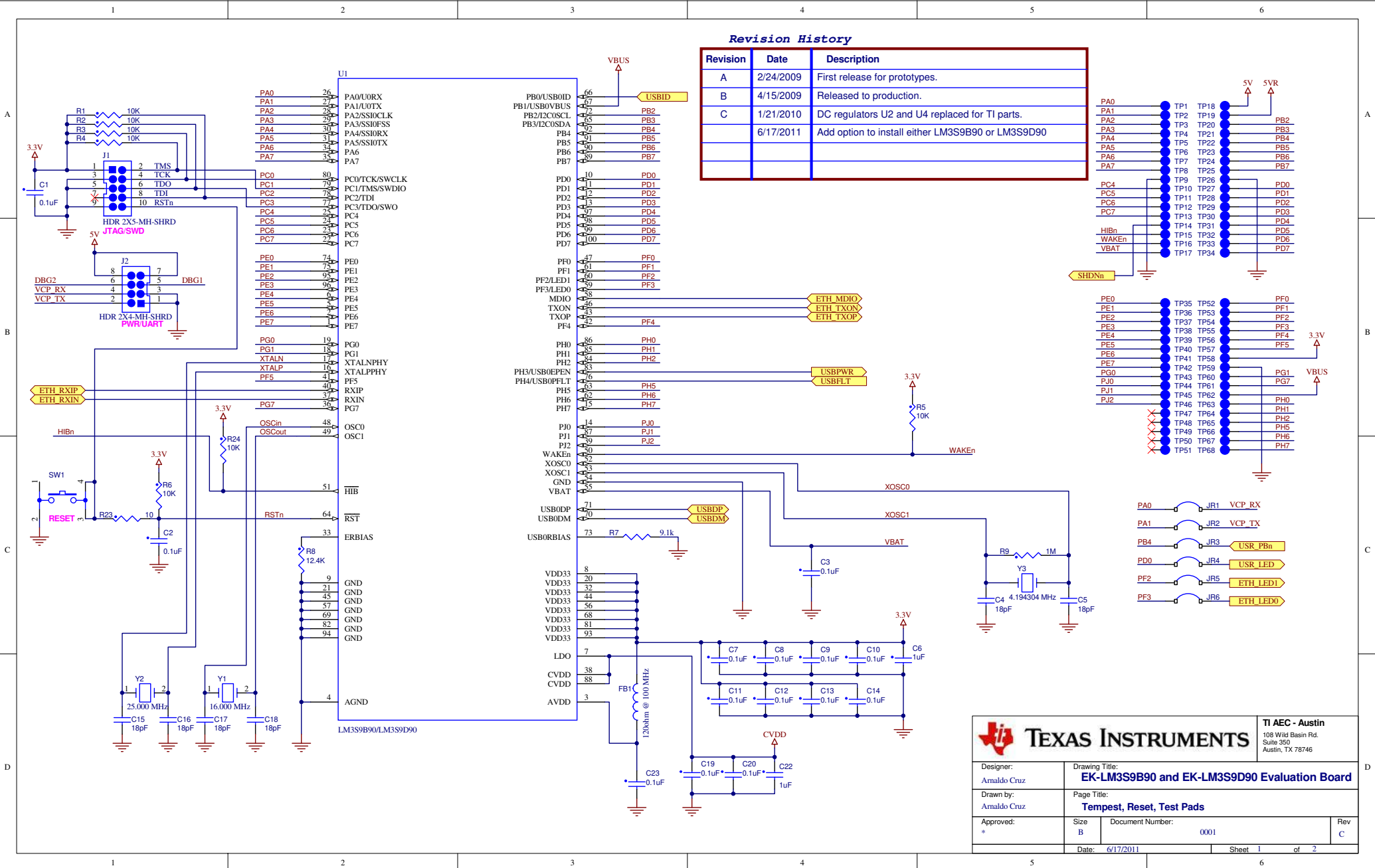

		TI AEC - Austin 108 Wild Basin Rd. Suite 350 Austin, TX 78746		
		Designer: Arnaldo Cruz	Drawing Title: EK-LM3S9B90 and EK-LM3S9D90 Evaluation Board	
Drawn by: Arnaldo Cruz		Page Title: Tempest, Reset, Test Pads		
Approved: +	Size B	Document Number: 0001	Rev C	
Date: 6/17/2011		Sheet 1 of 2		

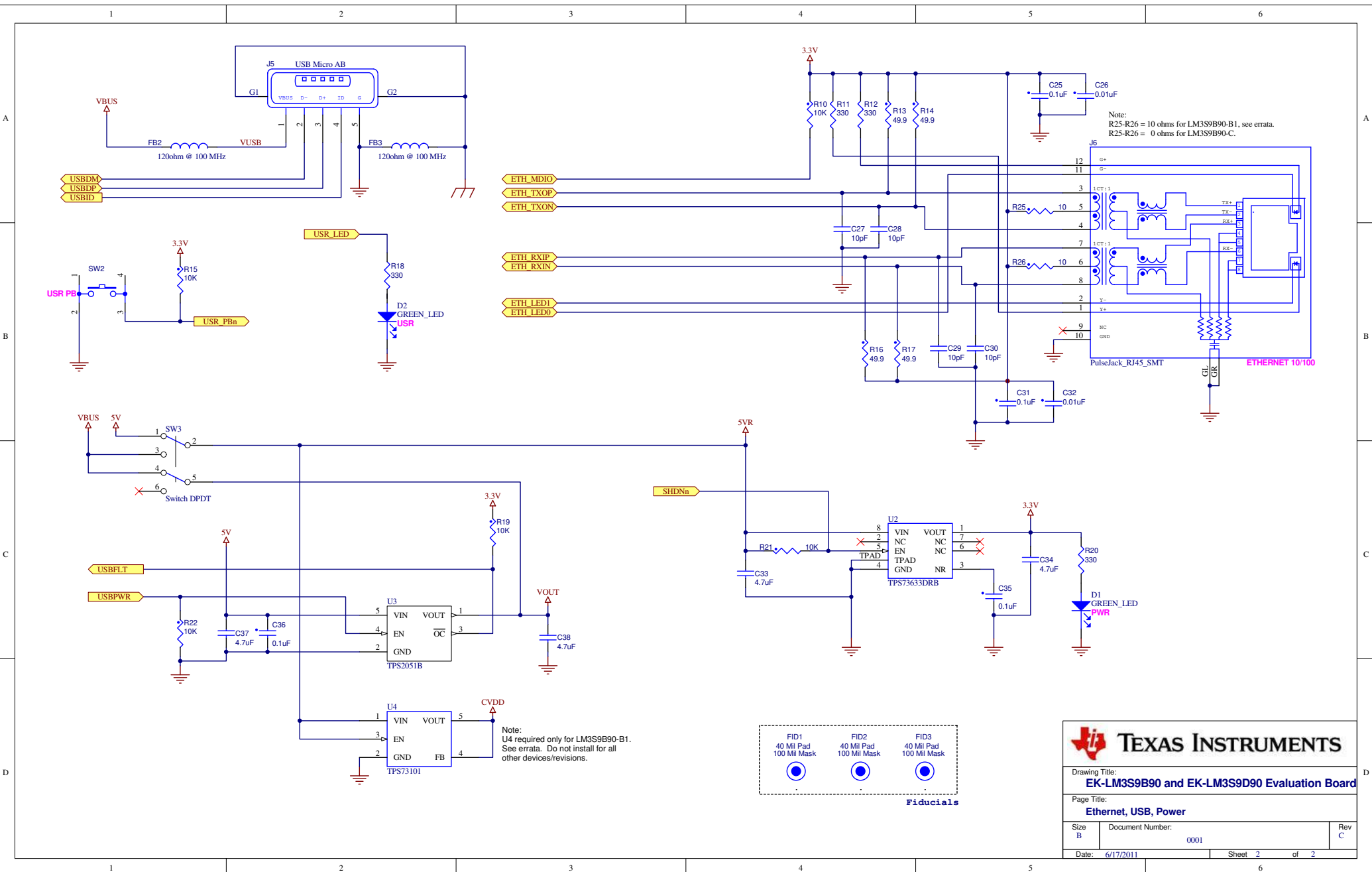

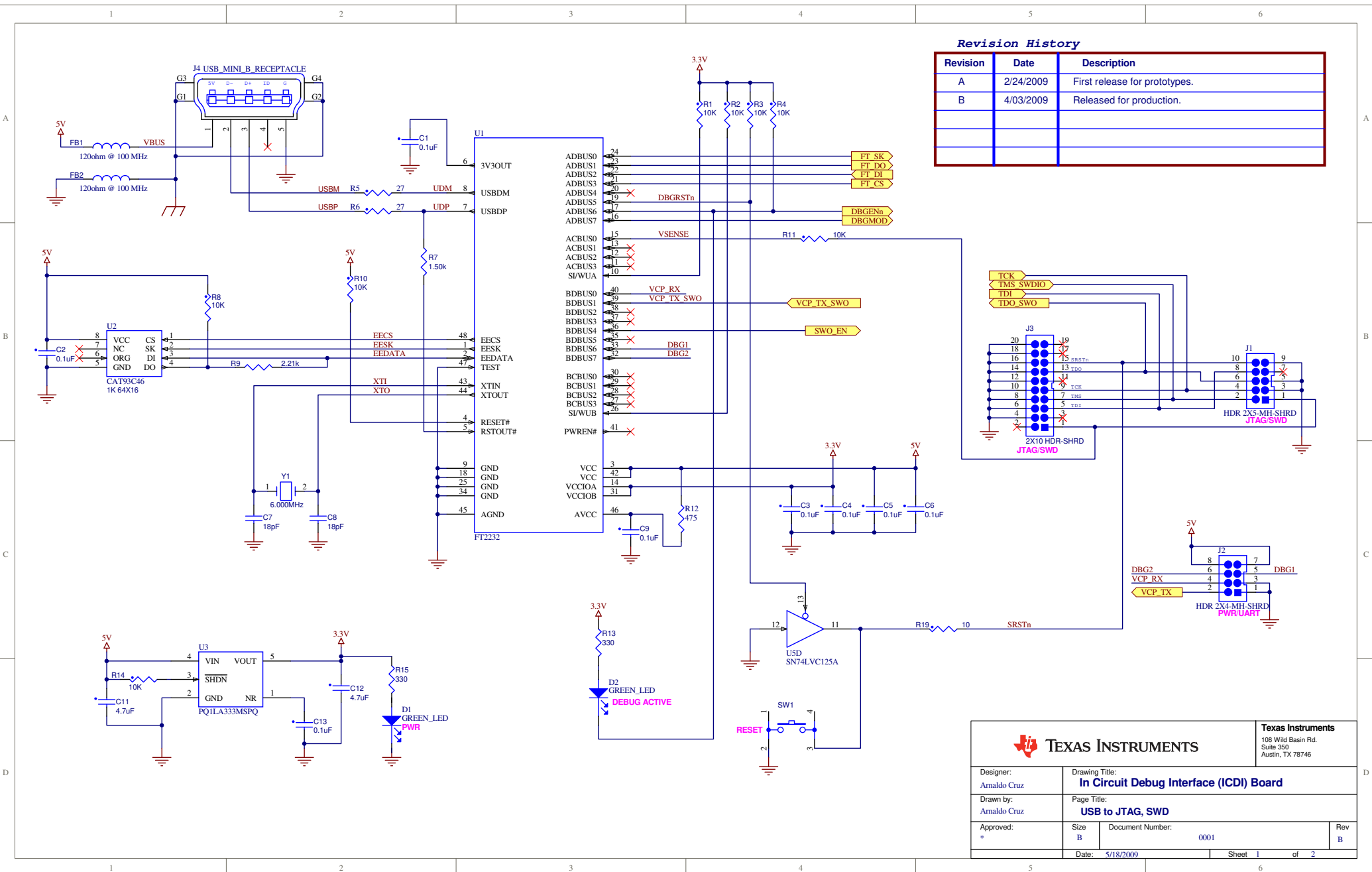

Revision History

Revision	Date	Description
A	2/24/2009	First release for prototypes.
B	4/03/2009	Released for production.

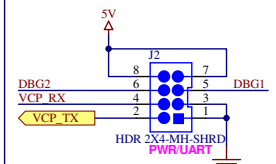
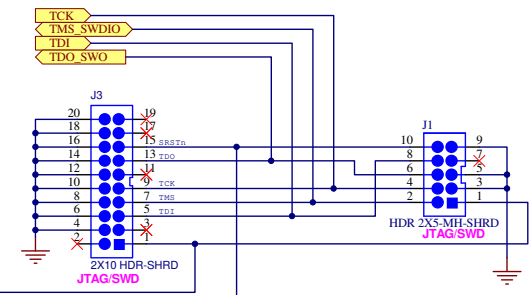

		TEXAS INSTRUMENTS 108 Wild Basin Rd. Suite 350 Austin, TX 78746	
Designer: Arnaldo Cruz	Drawing Title: In Circuit Debug Interface (ICDI) Board		
Drawn by: Arnaldo Cruz	Page Title: USB to JTAG, SWD		
Approved: *	Size B	Document Number: 0001	Rev B
Date: 5/18/2009		Sheet 1 of 2	

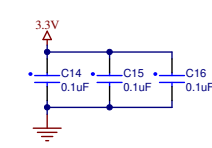
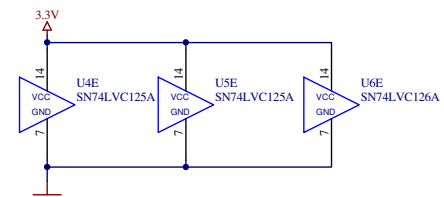
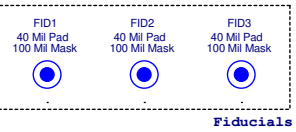
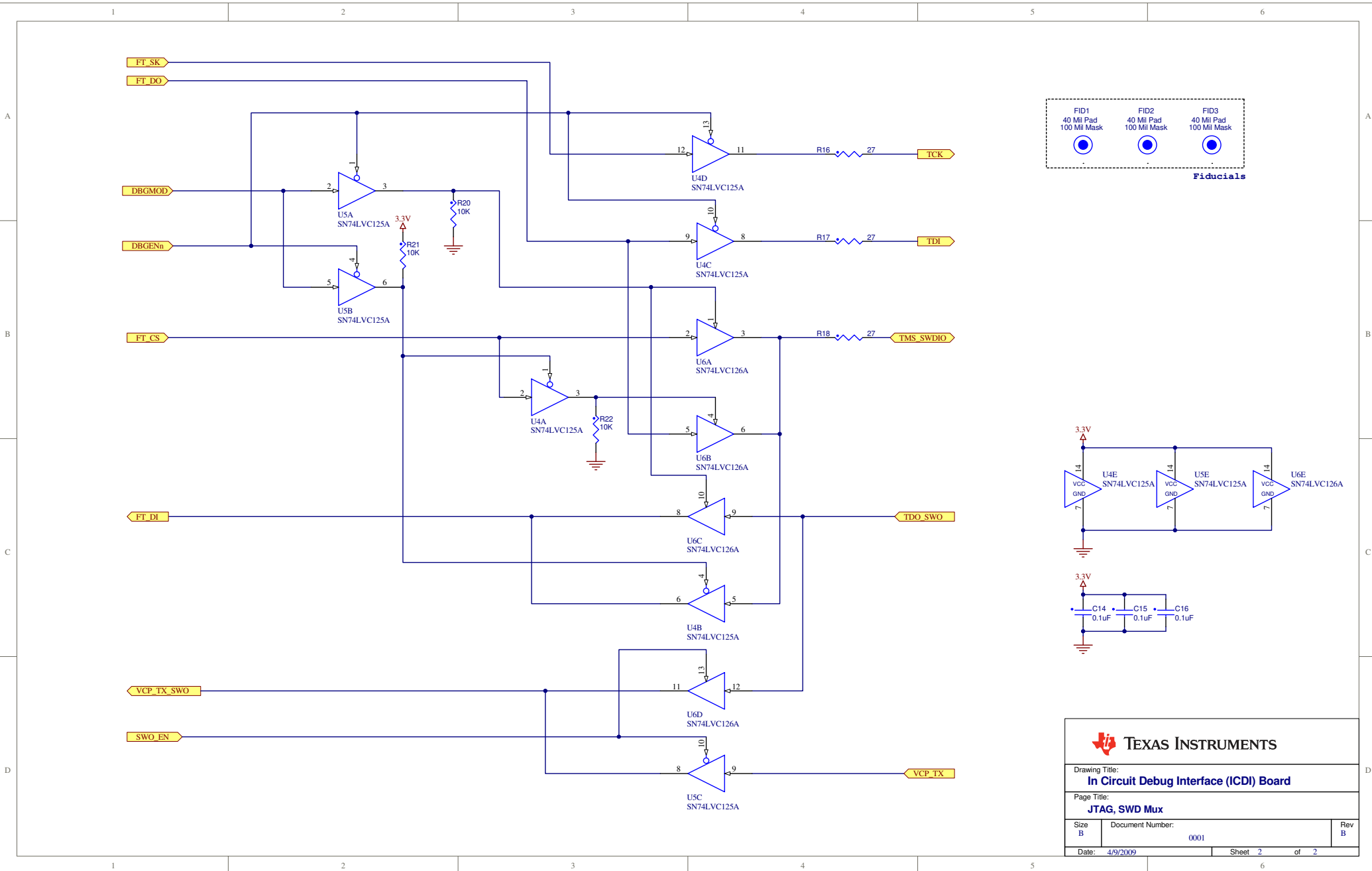

TEXAS INSTRUMENTS

Drawing Title:
In Circuit Debug Interface (ICDI) Board

Page Title:
JTAG, SWD Mux

Size B	Document Number: 0001	Rev B
Date: 4/9/2009	Sheet 2 of 2	

APPENDIX B

Connection Details

This appendix contains the following sections:

- Component Locations (see page 25)
- Board Dimensions (see page 26)
- Board Connectivity (see page 27)
- References (see page 27)

Component Locations

Figure B-1. EK-LM3S9D90 Evaluation Board Component Locations

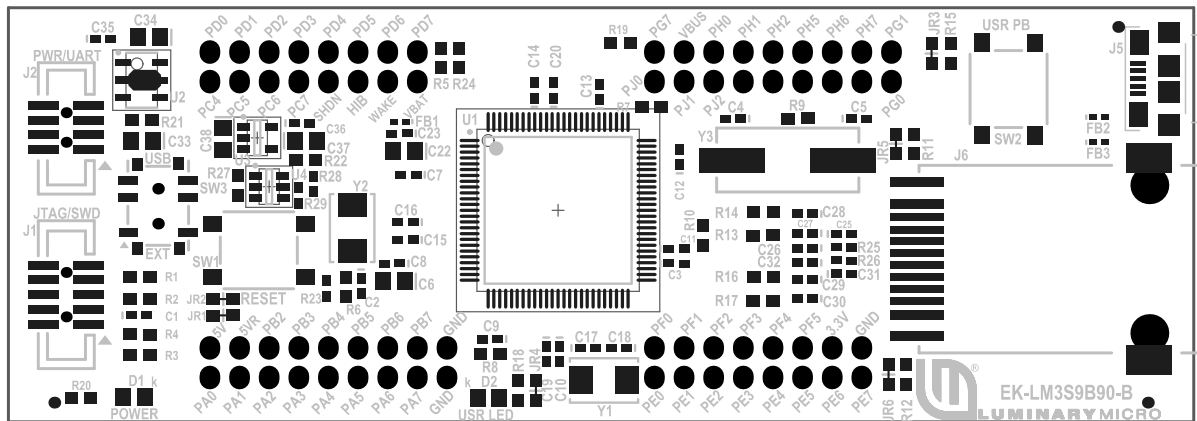
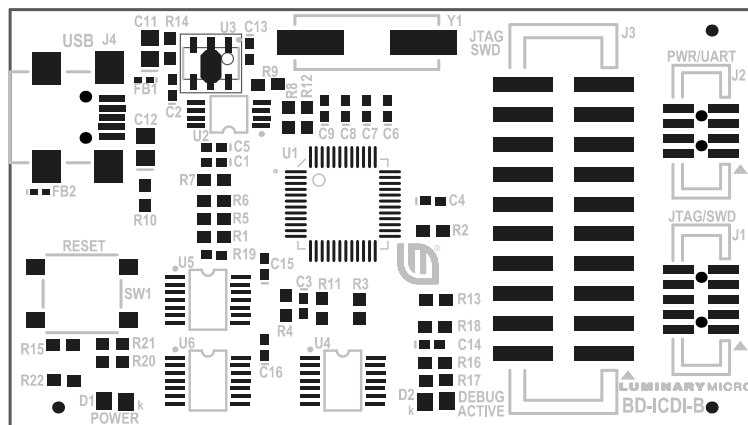

Figure B-2. BD-ICDI Board Component Locations



Board Dimensions

Figure B-3. EK-LM3S9D90 Evaluation Board Dimensions

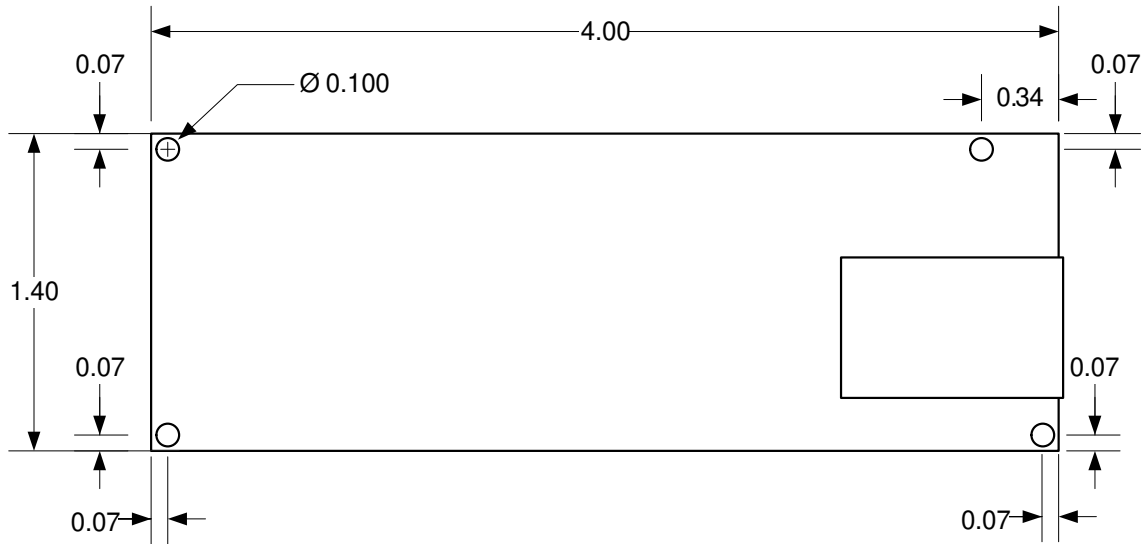
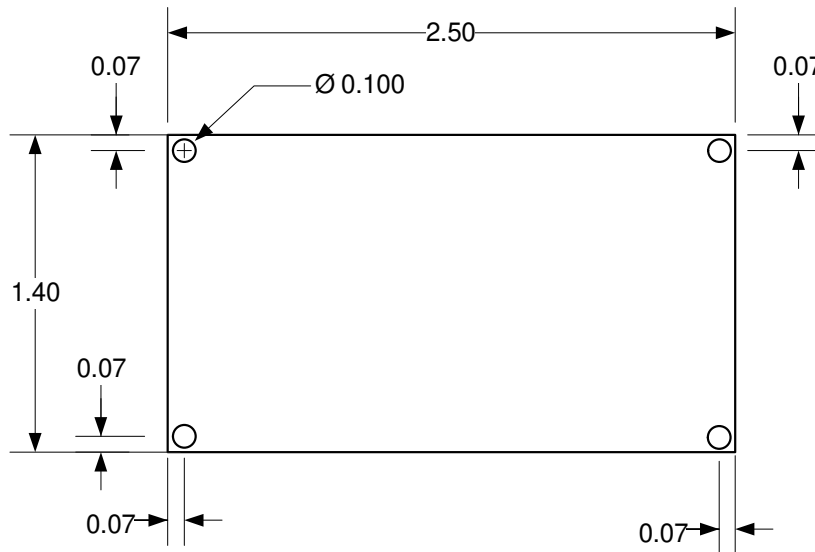
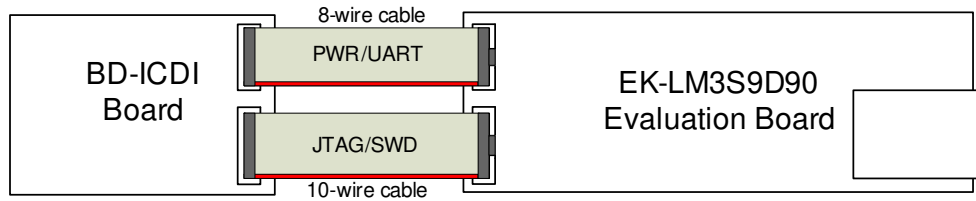

Figure B-4. In-Circuit Debug Interface Board Dimensions



Board Connectivity

Figure B-5. ICDI – EK-LM3S9D90 Board Connectivity



References

In addition to this document, the following references are included on the Stellaris Evaluation Kit CD-ROM and are also available for download at www.ti.com/stellaris:

- *Stellaris LM3S9D90 Data Sheet*, publication DS-LM3S9D90
- StellarisWare Driver Library
- *StellarisWare Driver Library User's Manual*, publication SW-DRL-UG

Additional references include:

- *FT232D Dual USB/UART FIFO IC Datasheet*, version 0.91, 2006, Future Technology Devices International Ltd.
- Information on development tool being used:
 - RealView MDK web site, www.keil.com/arm/rvmdkkit.asp
 - IAR Embedded Workbench web site, www.iar.com
 - Sourcery CodeBench development tools web site, www.codesourcery.com/gnu_toolchains/arm
 - Code Red Technologies development tools web site, www.code-red-tech.com
 - Texas Instruments' Code Composer Studio™ IDE web site, www.ti.com/ccs

A P P E N D I X C

Microcontroller GPIO Assignments

The following table shows the *LM3S9D90* GPIOs used by the *EK-LM3S9D90* board. All other GPIOs are available for use and accessible on the test pads.

Table C-1. EK-LM3S9D90 Evaluation Board GPIO Usage

Port	Function	Board Signal	Usage	Description
PA0	U0RX	VCP_RX	UART	Virtual Communications port receive signal from J2 header. To disconnect from header cut JR1 jumper.
PA1	U0TX	VCP_TX		Virtual Communications port transmit signal to J2 header. To disconnect from header cut JR2 jumper.
PB0	USB0ID	USBID	USB	USBID signal from the USB-On-the-Go connector J5.
PB1	USB0VBUS	VBUS		USB VBUS input signal from USB-OTG connector J5 for sensing VBUS levels.
PB4	GPIO	USR_PBn	User	Input from user pushbutton SW2. To disconnect from pushbutton cut JR3 jumper.
PC0	TCK/SWCLK	PC0	JTAG/ SWD	JTAG or SWD clock input
PC1	TMS/SWDIO	PC1		JTAG TMS input or SWD bidirectional signal SWDIO
PC2	TDI	PC2		JTAG TDI signal input.
PC3	TDO/SWO	PC3		JTAG TDO output or SWD trace signal SWO output.
PD0	GPIO	USR_LED	User	Output to user LED D2. To disconnect from LED cut JR4 jumper.
PF2	LED1	ETH_LED1	Ethernet	Output to RJ45 jack J6 yellow LED. To disconnect from LED cut JR5 jumper.
PF3	LED0	ETH_LED0		Output to RJ45 jack J6 green LED. To disconnect from LED cut JR6 jumper.
PH3	USB0EPEN	USBPWR	USB	Output to USB-OTG power switch U3. When set high it enables the USB-OTG power switch to provide USB VBUS power to USB-OTG connector J5. When set low power switch U3 is disabled.
PH4	USB0PFLT	USBPFLT		Overcurrent input status from USB-OTG power switch U3. When high the power switch status is normal. When low an overcurrent condition has been detected by the switch.

IMPORTANT NOTICE

Texas Instruments Incorporated and its subsidiaries (TI) reserve the right to make corrections, modifications, enhancements, improvements, and other changes to its products and services at any time and to discontinue any product or service without notice. Customers should obtain the latest relevant information before placing orders and should verify that such information is current and complete. All products are sold subject to TI's terms and conditions of sale supplied at the time of order acknowledgment.

TI warrants performance of its hardware products to the specifications applicable at the time of sale in accordance with TI's standard warranty. Testing and other quality control techniques are used to the extent TI deems necessary to support this warranty. Except where mandated by government requirements, testing of all parameters of each product is not necessarily performed.

TI assumes no liability for applications assistance or customer product design. Customers are responsible for their products and applications using TI components. To minimize the risks associated with customer products and applications, customers should provide adequate design and operating safeguards.

TI does not warrant or represent that any license, either express or implied, is granted under any TI patent right, copyright, mask work right, or other TI intellectual property right relating to any combination, machine, or process in which TI products or services are used. Information published by TI regarding third-party products or services does not constitute a license from TI to use such products or services or a warranty or endorsement thereof. Use of such information may require a license from a third party under the patents or other intellectual property of the third party, or a license from TI under the patents or other intellectual property of TI.

Reproduction of TI information in TI data books or data sheets is permissible only if reproduction is without alteration and is accompanied by all associated warranties, conditions, limitations, and notices. Reproduction of this information with alteration is an unfair and deceptive business practice. TI is not responsible or liable for such altered documentation. Information of third parties may be subject to additional restrictions.

Resale of TI products or services with statements different from or beyond the parameters stated by TI for that product or service voids all express and any implied warranties for the associated TI product or service and is an unfair and deceptive business practice. TI is not responsible or liable for any such statements.

TI products are not authorized for use in safety-critical applications (such as life support) where a failure of the TI product would reasonably be expected to cause severe personal injury or death, unless officers of the parties have executed an agreement specifically governing such use. Buyers represent that they have all necessary expertise in the safety and regulatory ramifications of their applications, and acknowledge and agree that they are solely responsible for all legal, regulatory and safety-related requirements concerning their products and any use of TI products in such safety-critical applications, notwithstanding any applications-related information or support that may be provided by TI. Further, Buyers must fully indemnify TI and its representatives against any damages arising out of the use of TI products in such safety-critical applications.

TI products are neither designed nor intended for use in military/aerospace applications or environments unless the TI products are specifically designated by TI as military-grade or "enhanced plastic." Only products designated by TI as military-grade meet military specifications. Buyers acknowledge and agree that any such use of TI products which TI has not designated as military-grade is solely at the Buyer's risk, and that they are solely responsible for compliance with all legal and regulatory requirements in connection with such use.

TI products are neither designed nor intended for use in automotive applications or environments unless the specific TI products are designated by TI as compliant with ISO/TS 16949 requirements. Buyers acknowledge and agree that, if they use any non-designated products in automotive applications, TI will not be responsible for any failure to meet such requirements.

Following are URLs where you can obtain information on other Texas Instruments products and application solutions:

Products

Audio	www.ti.com/audio
Amplifiers	amplifier.ti.com
Data Converters	dataconverter.ti.com
DLP® Products	www.dlp.com
DSP	dsp.ti.com
Clocks and Timers	www.ti.com/clocks
Interface	interface.ti.com
Logic	logic.ti.com
Power Mgmt	power.ti.com
Microcontrollers	microcontroller.ti.com
RFID	www.ti-rfid.com
RF/IF and ZigBee® Solutions	www.ti.com/lprf

Applications

Communications and Telecom	www.ti.com/communications
Computers and Peripherals	www.ti.com/computers
Consumer Electronics	www.ti.com/consumer-apps
Energy and Lighting	www.ti.com/energy
Industrial	www.ti.com/industrial
Medical	www.ti.com/medical
Security	www.ti.com/security
Space, Avionics and Defense	www.ti.com/space-avionics-defense
Transportation and Automotive	www.ti.com/automotive
Video and Imaging	www.ti.com/video
Wireless	www.ti.com/wireless-apps

TI E2E Community Home Page

e2e.ti.com

Mailing Address: Texas Instruments, Post Office Box 655303, Dallas, Texas 75265
Copyright © 2011, Texas Instruments Incorporated