

Nuvoton

NCT5655Y/W

**16-bit I²C-bus and SMBus GPIO
controller with interrupt**

Revision: 1.0 Date: May, 2016

NCT5655Y/W Datasheet Revision History

	PAGES	DATES	VERSION	MAIN CONTENTS
1		18 th , May, 2016	1.0	Public release for MP
2.				

Table of Contents-

1. GENERAL DESCRIPTION	1
2. FEATURES	1
2.1 GENERAL FEATURES	1
2.2 KEY SPECIFICATIONS.....	1
3. PIN CONFIGURATION	2
4. PIN DESCRIPTION	3
5. BLOCK DIAGRAM	4
6. FUNCTION DESCRIPTIONS	5
6.1 ACCESS INTERFACE	5
6.1 POWER-ON RESET.....	6
6.2 I/O PORT	7
6.3 INTERRUPT OUTPUT.....	8
7. REGISTER DESCRIPTION	10
7.1 REGISTER 00H – GPIO0X INPUT PORT REGISTER	10
7.2 REGISTER 01H – GPIO1X INPUT PORT REGISTER	10
7.3 REGISTER 02H – GPIO0X OUTPUT PORT REGISTER	10
7.4 REGISTER 03H – GPIO1X OUTPUT PORT REGISTER	10
7.5 REGISTER 04H – GPIO0X POLARITY INVERSION REGISTER.....	11
7.6 REGISTER 05H – GPIO1X POLARITY INVERSION REGISTER.....	11
7.7 REGISTER 06H – GPIO0X CONFIGURATION REGISTER.....	11
7.8 REGISTER 07H – GPIO1X CONFIGURATION REGISTER.....	11
7.9 REGISTER 10H – INT#/LED/BEEP CONFIGURATION REGISTER.....	12
7.10 REGISTER 12H – GPIO0X OUTPUT TYPE REGISTER.....	12
7.11 REGISTER 13H – GPIO1X OUTPUT TYPE REGISTER.....	13
7.12 REGISTER 14H – LED CONFIGURATION REGISTER	13
7.13 REGISTER 15H – BEEP CONFIGURATION REGISTER	14
7.14 REGISTER 18H – REGISTER ON/OFF CONFIGURATION REGISTER.....	14
7.15 REGISTER 1DH – CHIP ID HIGH BYTE REGISTER	14
7.16 REGISTER 1EH – CHIP ID LOW BYTE REGISTER	14
8. DC AND AC SPECIFICATION	15
8.1 ABSOLUTE MAXIMUM RATINGS	15
8.2 DC CHARACTERISTICS.....	15
8.3 AC CHARACTERISTICS.....	17
9. ORDERING INFORMATION	19
10. TOP MARKING SPECIFICATION	19

11. PACKAGE DIMENSION OUTLINE20

11.1 QFN 24L 4x4MM², THICKNESS: 0.8MM, PITCH:0.50MM..... 20

11.2 TSSOP 24L 4.4x7.8 MM² 21

1. GENERAL DESCRIPTION

The NCT5655Y/W is a general purpose input/output IC with I²C-bus/SMBus that provides 16 bits of General Purpose Input/Output (GPIO) expansion. The GPIO expanders provide a simple solution when additional I/O is needed for push buttons, flashing LED output, BEEP functions, sensors and so on. It also provides an interrupt to inform the system master when a transition occurs on general purpose input pins.

The NCT5655Y/W provides I²C-bus/SMBus address setting pins to set the address during power-on reset or from external reset, allowing up to eight devices to share the same I²C-bus/SMBus.

2. FEATURES

2.1 General Features

- Operating power supply voltage range of 2.3 V to 5.5 V
- 5 V tolerant I/Os
- Polarity inversion register
- General purpose output setting for level or pulse mode
- Interrupt output setting for level or pulse mode
- Interrupt notification support for system event occurs
- Low standby current
- Noise filter on SCL/SDA inputs
- No glitch on power-up
- Internal power-on reset
- 16 I/O pins which default to 16 inputs with push-pull or open-drain selection
- Flashing LED output
- PC beep output
- 0 Hz to 400 kHz clock frequency
- Halogen free packages (RoHS Compliant) offered: QFN24 and TSSOP24

2.2 Key Specifications

- Supply Voltage is 2.3 V to 5.5 V
- Standby Current is 1uA max.
- Operating Temperature is from -40 °C to 85 °C

3. PIN CONFIGURATION

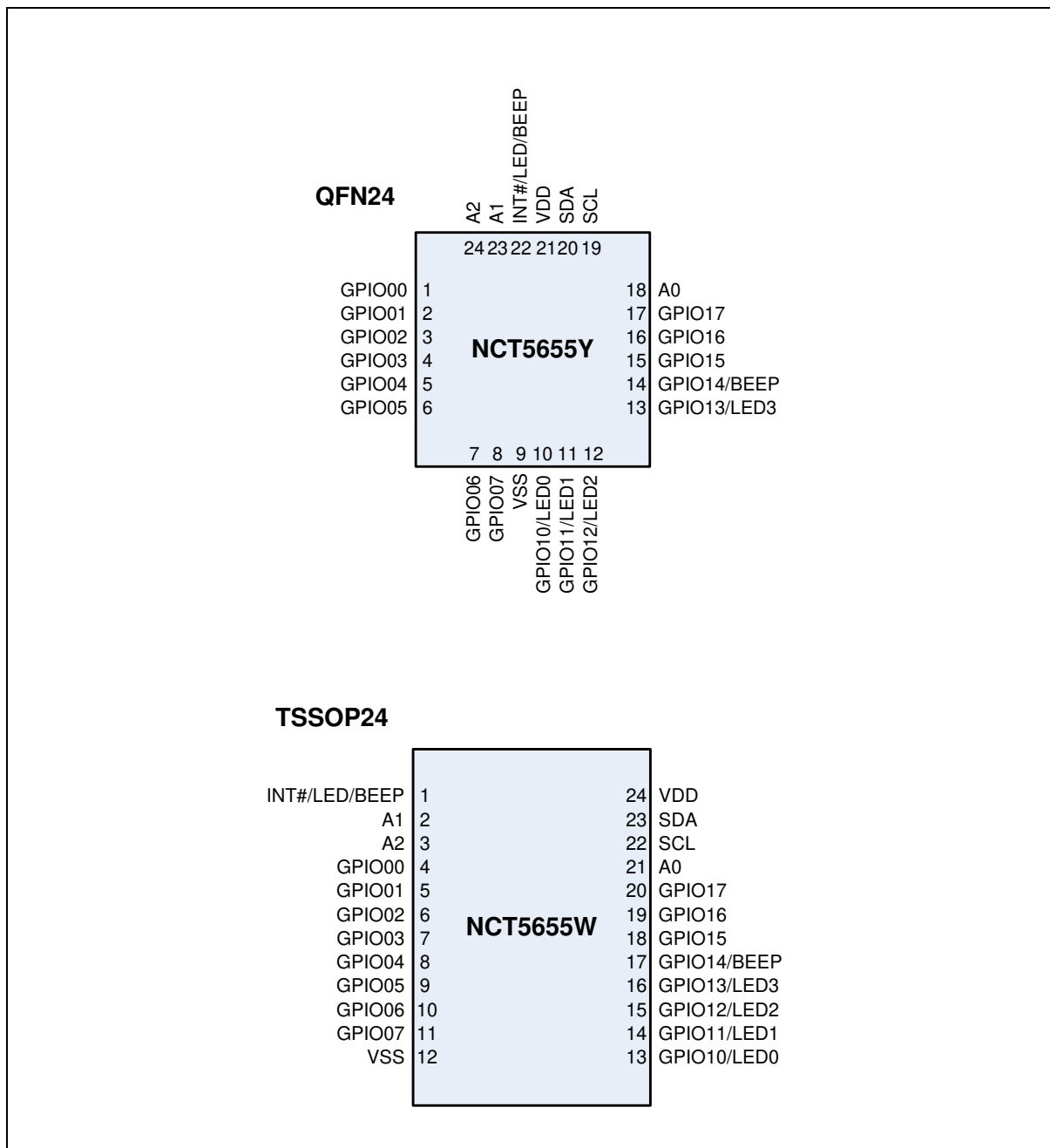

4. PIN DESCRIPTION

Symbol	Pin		Description
	TSSOP24	QFN24	
INT#/LED/BEEP	1	22	Interrupt output (open-drain), or LED or BEEP output (push-pull)
A1	2	23	Address input 1 (Connect directly to VDD or VSS)
A2	3	24	Address input 2 (Connect directly to VDD or VSS)
GPIO00	4	1	General purpose input/output (GPIO00)
GPIO01	5	2	General purpose input/output (GPIO01)
GPIO02	6	3	General purpose input/output (GPIO02)
GPIO03	7	4	General purpose input/output (GPIO03)
GPIO04	8	5	General purpose input/output (GPIO04)
GPIO05	9	6	General purpose input/output (GPIO05)
GPIO06	10	7	General purpose input/output (GPIO06)
GPIO07	11	8	General purpose input/output (GPIO07)
VSS	12	9	Supply ground
GPIO10/LED0	13	10	General purpose input/output (GPIO10) and LED signal output (LED0)
GPIO11/LED1	14	11	General purpose input/output (GPIO11) and LED signal output (LED1)
GPIO12/LED2	15	12	General purpose input/output (GPIO12) and LED signal output (LED2)
GPIO13/LED3	16	13	General purpose input/output (GPIO13) and LED signal output (LED3)
GPIO14/BEEP	17	14	General purpose input/output (GPIO14) and BEEP signal output (BEEP)
GPIO15	18	15	General purpose input/output (GPIO15)
GPIO16	19	16	General purpose input/output (GPIO16)
GPIO17	20	17	General purpose input/output (GPIO17)
A0	21	18	Address input 0 (Connect directly to VDD or VSS)
SCL	22	19	Serial clock line (Connect to VDD through a pull-up resistor)
SDA	23	20	Serial data line (Connect to VDD through a pull-up resistor)
VDD	24	21	Supply voltage

5. BLOCK DIAGRAM

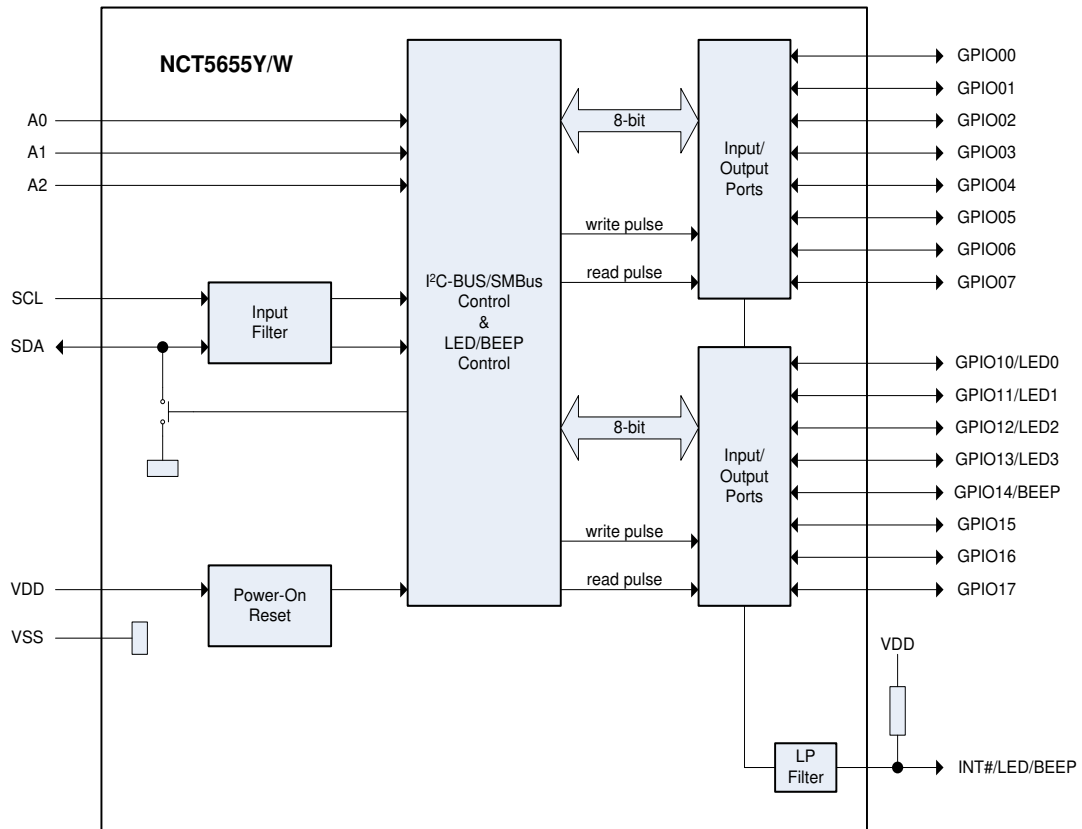

6. FUNCTION DESCRIPTIONS

6.1 Access Interface

NCT5655Y/W provides a two-wired serial interface which is compliant with I²C-bus/SMBus Write Byte and Read Byte protocol.

NCT5655Y/W I²C-bus/SMBus Address is:

Inputs			I ² C-bus/SMBus slave address (0, 1, 0, 0, A2, A1, A0, R/W)
A2	A1	A0	
L	L	L	40h
L	L	H	42h
L	H	L	44h
L	H	H	46h
H	L	L	48h
H	L	H	4Ah
H	H	L	4Ch
H	H	H	4Eh

6.1.1 Write to output port registers

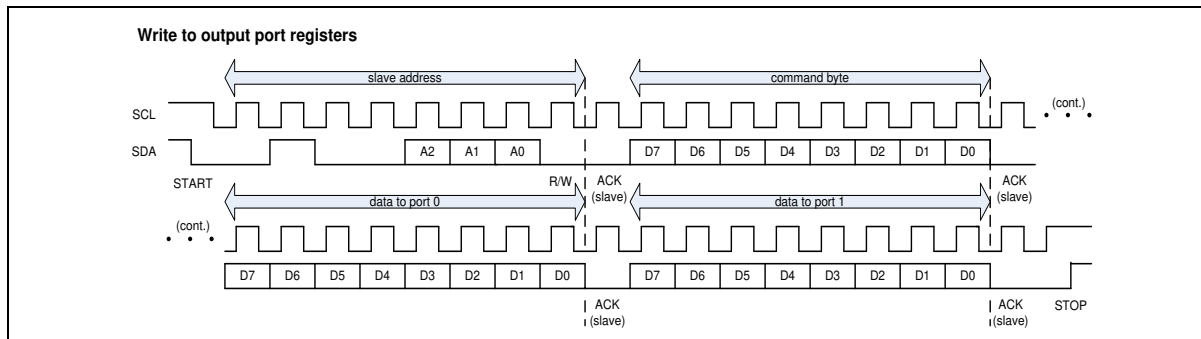

Data is transmitted to the NCT5655Y/W by sending the device address and setting the least significant bit to a logic 0. The command byte is sent after the address and determines which register will receive the data following the command byte.

The eight registers within the NCT5655Y/W are configured to operate as four registers pairs. The four pairs are Input Ports, Output Ports, Polarity Inversion Ports, and Configuration Ports. After sending data to one register, the next data byte will be sent to the other register in the pair. For example, if the first byte is sent to Output Port 1 (register 3), then the next byte will be stored in Output Port 0 (register 2). There is no limitation on the number of data bytes sent in one write transmission. In this way, each 8-bit register may be updated independently of the other registers.

6.1.2 Read from output port registers

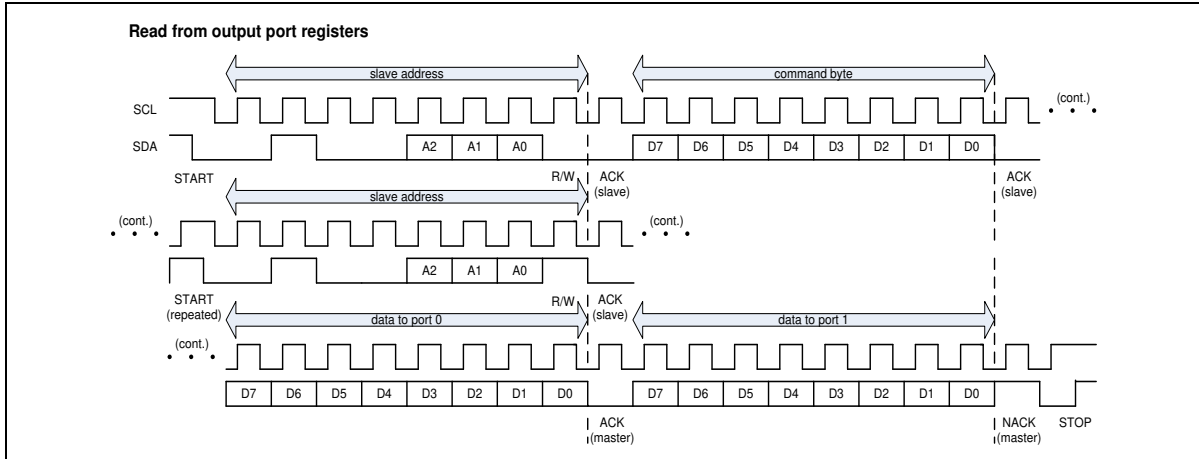

In order to read data from the NCT5655Y/W, the bus master must first send the NCT5655Y/W address with the least significant bit set to a logic 0. The command byte is sent after the address and determines which register will be accessed. After a restart, the device address is sent again, but this time the least significant bit is set to a logic 1. Data from the register defined by the command byte will then be sent by the NCT5655Y/W. Data is clocked into the register on the falling edge of the acknowledge clock pulse. After the first byte is read, additional bytes may be read out the data will now reflect the information in the other register in the pair. For example, if you read Input Port 1, then the next byte read would be Input Port 0. There is no limitation on the number of data bytes received in one read transmission but the final byte received, the bus master must not acknowledge the data.

6.1 Power-On Reset

When power is applied to VDD, an internal power-on reset holds the NCT5655Y/W in a reset condition until VDD has reached V_{POR}. At that point, the reset condition is released and the NCT5655Y/W registers and I²C-bus/SMBus state machine will initialize to their default states. The power-on reset typically completes the reset and enables the part by the time the power supply is above V_{POR}. However, when it is required to reset the part by lowering the power supply, it is necessary to lower it below 0.2 V.

6.2 I/O Port

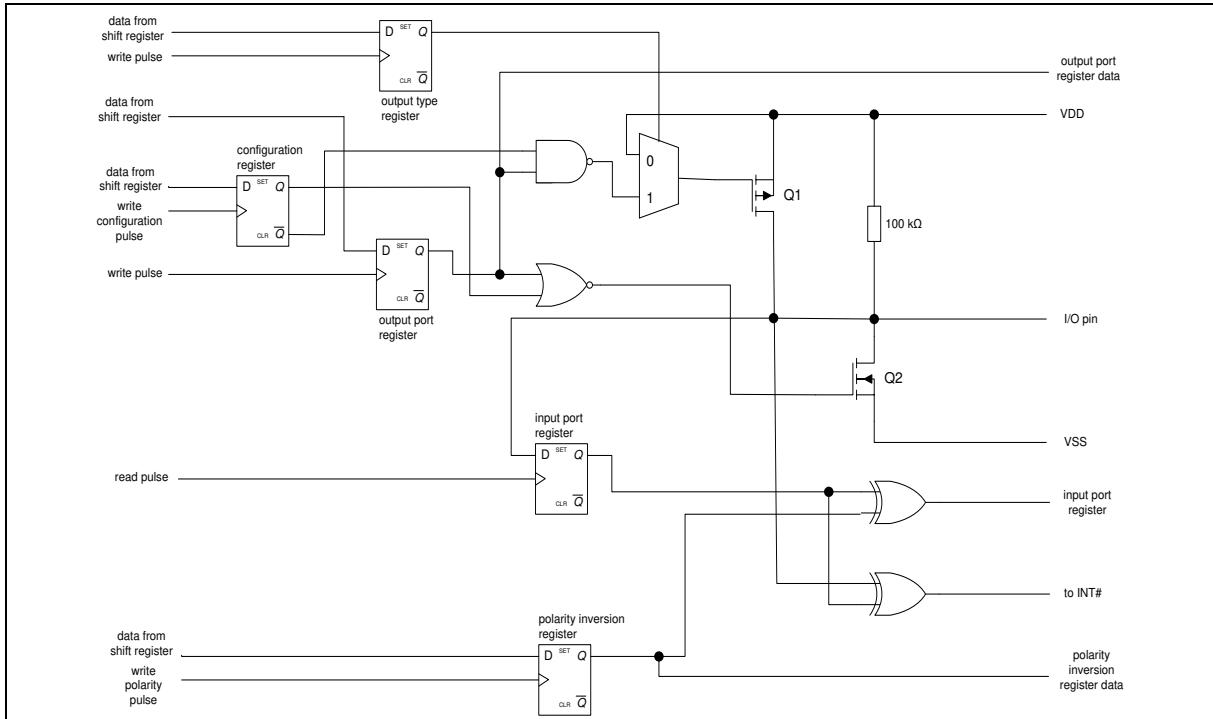

When an I/O is configured as an input (default), FETs Q1 and Q2 are off, creating a high-impedance input with a weak pull-up to VDD. The input voltage may be raised above VDD to a maximum of 5.5 V.

If the I/O is configured as an output, then either Q1 or Q2 is on, depending on the state of the Output Port register. Care should be exercised if an external voltage is applied to an I/O configured as an output because of the low-impedance path that exists between the pin and either VDD or VSS.

*GPIO Output Table:

GPIO CONFIGURATION REGISTER	OUTPUT PORT REGISTER	OUTPUT VALUE AT PIN	WAVE
0	0	0	_____
	1	1	_____

6.3 Interrupt Output

The open-drain interrupt output is activated when one of the port pins changes state and the pin is configured as an input. The interrupt is deactivated when the input returns to its previous state or the Input Port register is read. A pin configured as an output cannot cause an interrupt. Since each 8-bit port is read independently, the interrupt caused by Port 0 will not be cleared by a read of Port 1 or the other way around.

Example 1: GPIO00 input; polarity register set '0'; level output (Input Port register is read)

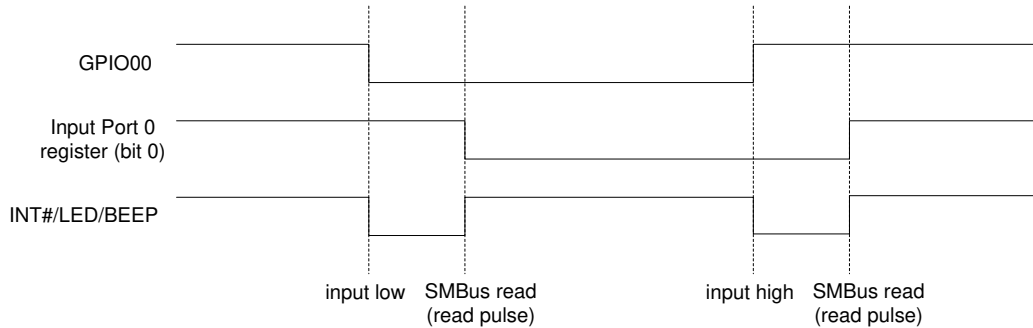

Example 2: GPIO00 input; polarity register set '0'; level output (input returns to its previous state)

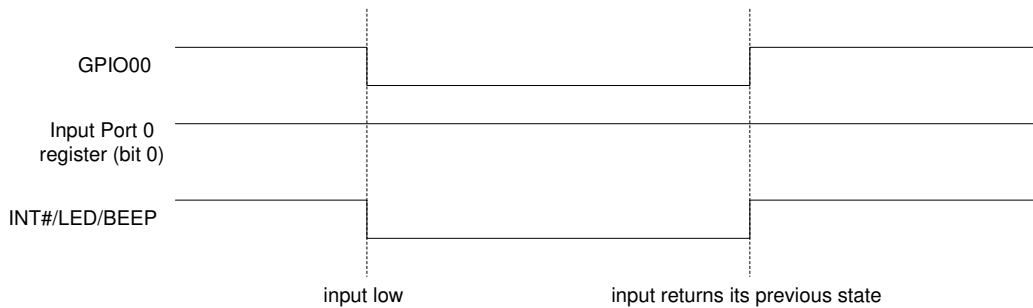

Example 3: GPIO00 input; polarity register set '0'; pulse output (Input Port register is read)

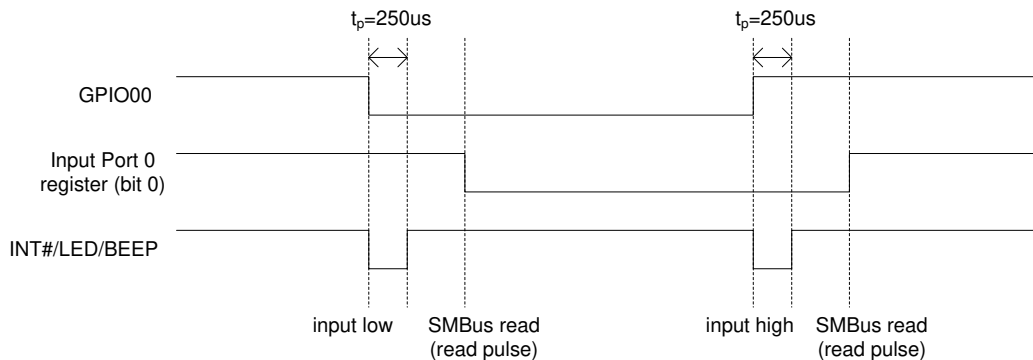

Example 4: GPIO00 input; polarity register set '0'; pulse output (input returns to its previous state)

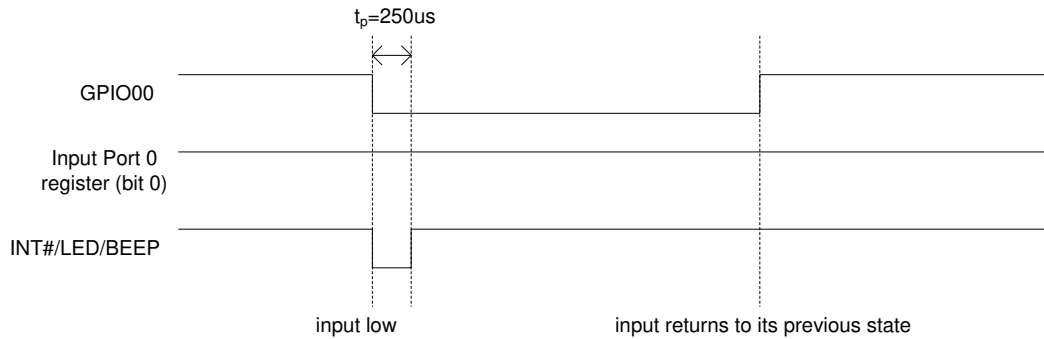

*INT#/LED/BEEP output LED signal during low period when it is configured to LED output.

*INT#/LED/BEEP output BEEP signal during low period when it is configured to BEEP output.

INT# Output Mode Table:

INT OUTPUT MODE	POLARITY	OUTPUT	WAVE
Level	0	0	
	1	1	
Pulse	0	Low Pulse	
	1	High Pulse	

*In level mode, if INT# is activated, it will be de-activated when Input Port register is read or when input returns to its previous state. (Example 1~2)

*In pulse mode, interrupt will be activated again unless Input Port register is read or unless input returns to its previous state and changes again. (Example 3~4)

*The INT# pulse mode output waveform width is 250uS.

* The control register is Register 10h.

7. REGISTER DESCRIPTION

7.1 Register 00h – GPIO0x Input port register

This register is an input-only port. It reflects the incoming logic levels of the pins, regardless of whether the pin is defined as an input or an output by Register 06h. This register is read only.

BIT	7	6	5	4	3	2	1	0
R/W	RO	RO	RO	RO	RO	RO	RO	RO
Default	X	X	X	X	X	X	X	X

*This register reflects the respective GPIO0 pins level.

*The default value 'X' is determined by the externally applied logic level.

7.2 Register 01h – GPIO1x Input port register

This register is an input-only port. It reflects the incoming logic levels of the pins, regardless of whether the pin is defined as an input or an output by Register 07h. This register is read only.

BIT	7	6	5	4	3	2	1	0
R/W	RO	RO	RO	RO	RO	RO	RO	RO
Default	X	X	X	X	X	X	X	X

*This register reflects the respective GPIO1 pins level.

*The default value 'X' is determined by the externally applied logic level.

7.3 Register 02h – GPIO0x Output port register

This register is an output-only port. It reflects the outgoing logic levels of the pins defined as outputs by Register 06h. Bit values in this register have no effect on pins defined as inputs. In turn, reads from this register reflect the value that is in the flip-flop controlling the output selection, not the actual pin value.

BIT	7	6	5	4	3	2	1	0
R/W	RW	RW	RW	RW	RW	RW	RW	RW
Default	1	1	1	1	1	1	1	1

7.4 Register 03h – GPIO1x Output port register

This register is an output-only port. It reflects the outgoing logic levels of the pins defined as outputs by Register 07h. Bit values in this register have no effect on pins defined as inputs. In turn, reads from this register reflect the value that is in the flip-flop controlling the output selection, not the actual pin value.

BIT	7	6	5	4	3	2	1	0
R/W	RW	RW	RW	RW	RW	RW	RW	RW
Default	1	1	1	1	1	1	1	1

7.5 Register 04h – GPIO0x Polarity Inversion register

This register allows the user to invert the polarity of the Input port register data. If a bit in this register is set (written with '1'), the Input port data polarity is inverted. If a bit in this register is cleared (written with '0'), the Input port data polarity is retained.

BIT	7	6	5	4	3	2	1	0
R/W	RW	RW	RW	RW	RW	RW	RW	RW
Default	0	0	0	0	0	0	0	0

7.6 Register 05h – GPIO1x Polarity Inversion register

This register allows the user to invert the polarity of the Input port register data. If a bit in this register is set (written with '1'), the Input port data polarity is inverted. If a bit in this register is cleared (written with '0'), the Input port data polarity is retained.

BIT	7	6	5	4	3	2	1	0
R/W	RW	RW	RW	RW	RW	RW	RW	RW
Default	0	0	0	0	0	0	0	0

7.7 Register 06h – GPIO0x Configuration register

This register configures the directions of the I/O pins. If a bit in this register is set (written with '1'), the corresponding port pin is enabled as an input with high-impedance output driver. If a bit in this register is cleared (written with '0'), the corresponding port pin is enabled as an output. Note that there is a high value resistor tied to VDD at each pin. At reset, the device's ports are inputs with a pull-up to VDD.

BIT	7	6	5	4	3	2	1	0
R/W	RW	RW	RW	RW	RW	RW	RW	RW
Default	1	1	1	1	1	1	1	1

*This register configures the respective GPIO0 pins as input mode ('1') or output mode ('0').

7.8 Register 07h – GPIO1x Configuration register

This register configures the directions of the I/O pins. If a bit in this register is set (written with '1'), the corresponding port pin is enabled as an input with high-impedance output driver. If a bit in this register is cleared (written with '0'), the corresponding port pin is enabled as an output. Note that there is a high value resistor tied to VDD at each pin. At reset, the device's ports are inputs with a pull-up to VDD.

BIT	7	6	5	4	3	2	1	0
R/W	RW	RW	RW	RW	RW	RW	RW	RW
Default	1	1	1	1	1	1	1	1

*This register configures the respective GPIO1 pins as input mode ('1') or output mode ('0').

7.9 Register 10h – INT#/LED/BEEP Configuration register

More INT#/LED/BEEP function description is in [6.3 Interrupt Output section](#).

BIT	7	6	5	4	3	2	1	0
R/W	RW	RW	RW	RW	RW	RW	RW	RW
Default	0	0	0	0	0	0	0	0

- Bit1-Bit0: INT# output select register
 - = 11, Reserved
 - = 10, BEEP output
 - = 01, LED output
 - = 00, INT# output
- Bit2: INT# output type register
 - = 1, Pulse mode
 - = 0, Level mode
- Bit3: INT# polarity select register
 - = 1, Inverted
 - = 0, Non-inverted
- Bit5-4: LED configuration register
 - =11, LED frequency = 2 Hz; duty-cycle 50%
 - =10, LED frequency = 1 Hz; duty-cycle 50%
 - =01, LED frequency = 0.5 Hz; duty-cycle 50%
 - =00, LED function is disabled
- Bit7-6: BEEP configuration register
 - =11, BEEP frequency = 4K Hz; tone = 250 Hz
 - =10, BEEP frequency = 2K Hz; tone = 10 Hz
 - =01, BEEP frequency = 1K Hz / 500 Hz; tone= 1 Hz
 - =00, BEEP function is disabled

7.10 Register 12h – GPIO0x Output type register

This register configures the output type of the GPIO0 I/O pins. If a bit in this register is set (written with '1'), the corresponding output port is enabled as a push-pull output driver. If a bit in this register is cleared (written with '0'), the corresponding output port is enabled as an open-drain output driver. Note that there is a high value resistor tied to VDD at each pin.

BIT	7	6	5	4	3	2	1	0
R/W	RW	RW	RW	RW	RW	RW	RW	RW
Default	1	1	1	1	1	1	1	1

*This register configures the respective GPIO0 pins as push-pull mode ('1') or open-drain mode ('0').

7.11 Register 13h – GPIO1x Output type register

This register configures the output type of the GPIO1 I/O pins. If a bit in this register is set (written with '1'), the corresponding output port is enabled as a push-pull output driver. If a bit in this register is cleared (written with '0'), the corresponding output port is enabled as an open-drain output driver. Note that there is a high value resistor tied to VDD at each pin.

BIT	7	6	5	4	3	2	1	0
R/W	RW	RW	RW	RW	RW	RW	RW	RW
Default	1	1	1	1	1	1	1	1

*This register configures the respective GPIO1 pins as push-pull mode ('1') or open-drain mode ('0').

7.12 Register 14h – LED Configuration register

This register configures the output signal of the GPIO10/LED0~GPIO13/LED3 I/O pins. When output LED signal, the pin must define as an output by Register 07h. For GPIO function use, the corresponding register must set to "00".

BIT	7	6	5	4	3	2	1	0
R/W	RW	RW	RW	RW	RW	RW	RW	RW
Default	0	0	0	0	0	0	0	0

- Bit1-Bit0: GPIO10/LED0 configuration register
 - =11, LED frequency = 2 Hz; duty-cycle 50%
 - =10, LED frequency = 1 Hz; duty-cycle 50%
 - =01, LED frequency = 0.5 Hz; duty-cycle 50%
 - =00, LED function is disabled
- Bit3-Bit2: GPIO11/LED1 configuration register
 - =11, LED frequency = 2 Hz; duty-cycle 50%
 - =10, LED frequency = 1 Hz; duty-cycle 50%
 - =01, LED frequency = 0.5 Hz; duty-cycle 50%
 - =00, LED function is disabled
- Bit5-Bit4: GPIO12/LED2 configuration register
 - =11, LED frequency = 2 Hz; duty-cycle 50%
 - =10, LED frequency = 1 Hz; duty-cycle 50%
 - =01, LED frequency = 0.5 Hz; duty-cycle 50%
 - =00, LED function is disabled
- Bit7-Bit6: GPIO13/LED3 configuration register
 - =11, LED frequency = 2 Hz; duty-cycle 50%
 - =10, LED frequency = 1 Hz; duty-cycle 50%
 - =01, LED frequency = 0.5 Hz; duty-cycle 50%
 - =00, LED function is disabled

7.13 Register 15h – BEEP Configuration register

This register configures the output signal of the GPIO14/BEEP I/O pins. When output BEEP signal, the pin must define as an output by Register 07h. For GPIO function use, the corresponding register must set to "00".

BIT	7	6	5	4	3	2	1	0
R/W	RO	RO	RO	RO	RO	RO	RW	RW
Default	0	0	0	0	0	0	0	0

Bit1-0: GPIO14/BEEP configuration register
 =11, BEEP frequency = 4K Hz; tone = 250 Hz
 =10, BEEP frequency = 2K Hz; tone = 10 Hz
 =01, BEEP frequency = 1K Hz / 500 Hz; tone= 1 Hz
 =00, BEEP function is disabled

7.14 Register 18h – Register ON/OFF Configuration register

This register configures the register 10h~1Fh on/off for this chip.

BIT	7	6	5	4	3	2	1	0
R/W	RO	RO	RO	RO	RO	RO	RO	RW
Default	0	0	0	0	0	0	0	1

Bit0: Register 10h~1Fh ON/OFF configuration register
 =1, registers 10h~1Fh will be off.
 =0, registers 10h~1Fh will be on.

Bit7-1: Reserved.

7.15 Register 1Dh – Chip ID high byte register

This register indicates the high byte of the Chip ID.

BIT	7	6	5	4	3	2	1	0
R/W	RO	RO	RO	RO	RO	RO	RO	RO
Default	1	1	0	1	0	0	0	1

7.16 Register 1Eh – Chip ID low byte register

This register indicates the low byte of the Chip ID.

BIT	7	6	5	4	3	2	1	0
R/W	RO	RO	RO	RO	RO	RO	RO	RO
Default	0	1	0	0	X	X	X	X

Bit3-0: XXXX=0000~1111

8. DC AND AC SPECIFICATION

8.1 Absolute Maximum Ratings

PARAMETER	RATING	UNIT
Power Supply Voltage	2.3 to 5.5	V
Input Voltage	2.3 to 5.5	V
Operating Temperature	-40 to +85	°C

Note: Exposure to conditions beyond those listed under Absolute Maximum Ratings may adversely affect the life and reliability of the device.

8.2 DC Characteristics

DC characteristics at $V_{DD}=2.3V$ to $5.5V$; $V_{SS}=0V$; $T_{amb}=-40^{\circ}C$ to $+85^{\circ}C$; unless otherwise specified.

Symbol	Parameter	Conditions	Min.	Typ.	Max.	Unit
Supply						
V_{DD}	Supply Voltage		2.3	-	5.5	V
I_{DD}	Supply Current	Operating mode; $V_{DD}=5.5V$; no load; $f_{SCL}=100KHz$	-	135	200	μA
I_{stb}	Standby Current	Standby mode; $V_{DD}=5.5V$; no load; $V_I=V_{SS}$; $f_{SCL}=0KHz$; I/O=inputs	-	1.1	1.5	mA
		Standby mode; $V_{DD}=5.5V$; no load; $V_I=V_{DD}$; $f_{SCL}=0KHz$; I/O=inputs	-	0.25	1	μA
V_{POR}	Power-on reset voltage	No load; $V_I=V_{DD}$ or V_{SS}	-	1.5	1.65	V
Input SCL; input/output SDA						
V_{IL}	LOW-level input voltage		-0.5	-	$+0.3V_{DD}$	V
V_{IH}	HIGH-level input voltage		$0.7V_{DD}$	-	5.5	V
I_{OL}	LOW-level output current	$V_{OL}=0.4V$	3	-	-	mA
I_L	leakage current	$V_I=V_{DD}$ or V_{SS}	-1	-	+1	μA
C_i	input capacitance	$V_I=V_{SS}$	-	6	10	pF
I/Os						
V_{IL}	LOW-level input voltage		-0.5	-	$+0.3V_{DD}$	V

Symbol	Parameter	Conditions	Min.	Typ.	Max.	Unit
V _{IH}	HIGH-level input voltage		0.7V _{DD}	-	5.5	V
I _{OL}	LOW-level output current	V _{DD} =2.3V to 5.5V; V _{OL} =0.5V	8	(8 to 20)	-	mA
		V _{DD} =2.3V to 5.5V; V _{OL} =0.7V	10	(10 to 24)	-	mA
V _{OH}	HIGH-level output voltage	I _{OH} =-8mA; V _{DD} =2.3V	1.8	-	-	V
		I _{OH} =-10mA; V _{DD} =2.3V	1.7	-	-	V
		I _{OH} =-8mA; V _{DD} =3.0V	2.6	-	-	V
		I _{OH} =-10mA; V _{DD} =3.0V	2.5	-	-	V
		I _{OH} =-8mA; V _{DD} =4.75V	4.1	-	-	V
I _{OH} =-10mA; V _{DD} =4.75V	4.0	-	-	V		
I _{LIH}	HIGH-level input leakage current	V _{DD} =5.5V; V _I =V _{DD}	-	-	1	uA
I _{LIL}	LOW-level input leakage current	V _{DD} =5.5V; V _I =V _{DD}	-	-	-100	uA
C _i	input capacitance		-	3.7	5	pF
C _o	output capacitance		-	3.7	5	pF
Interrupt INT_N						
I _{OL}	LOW-level output current	V _{OL} =0.4V	3	-	-	mA
Select Inputs A0, A1, A2						
V _{IL}	LOW-level input voltage		-0.5	-	+0.3V _{DD}	V
V _{IH}	HIGH-level input voltage		0.7V _{DD}	-	5.5	V
I _{LI}	input leakage current	pin at V _{DD} or V _{SS}	-1	-	+1	uA

8.3 AC Characteristics

Symbol	Parameter	Conditions	Standard-mode		Fast-mode		Unit
			Min.	Max.	Min.	Max.	
f _{SCL}	SCL clock frequency		0	100	0	400	kHz
t _{BUF}	Bus free time between a STOP and START condition		4.7	-	1.3	-	us
t _{HD;STA}	Hold time (repeated) START condition		4.0	-	0.6	-	us
t _{SU;STA}	Set-up time for a repeated START condition		4.7	-	0.6	-	us
t _{SU;STO}	Set-up time for STOP condition		4.0	-	0.6	-	us
t _{VD;ACK}	Data valid acknowledge time		0.3	3.45	0.1	0.9	us
t _{HD;DAT}	Data hold time		0	-	0	-	us
t _{VD;DAT}	Data valid time		300	-	50	-	ns
t _{SU;DAT}	Data set-up time		250	-	100	-	ns
t _{LOW}	LOW period of the SCL clock		4.7	-	1.3	-	us
t _{HIGH}	HIGH period of the SCL clock		4.0	-	0.6	-	us
t _f	Fall time of both SDA and SCL signals		-	300	20+0.1C _b	300	ns
t _r	Rise time of both SDA and SCL signals		-	1000	20+0.1C _b	300	ns
C _b	Capacitive load for each bus line		-	400	-	400	pF
t _{SP}	Pulse width of spikes that must be suppressed by the input filter		-	50	-	50	ns
Port timing							
t _{v(Q)}	Data output valid time		-	200	-	200	ns
t _{su(D)}	Data input set-up time		150	-	150	-	ns
t _{h(D)}	Data input hold time		1	-	1	-	us
INT_N							
t _{v(INT_N)}	Valid time on pin INT_N		-	4	-	4	us
t _{rst(INT_N)}	Reset time on pin INT_N		-	4	-	4	us

[1] t_{VD;ACK} = Time for acknowledgement signal from SCL low to SDA out low.

[2] t_{VD;DAT} = Minimum time for SDA data out to be valid following SCL low.

[3] C_b = Total capacitance of one bus line in pF.

Definition of timing on the I²C-bus/SMBus

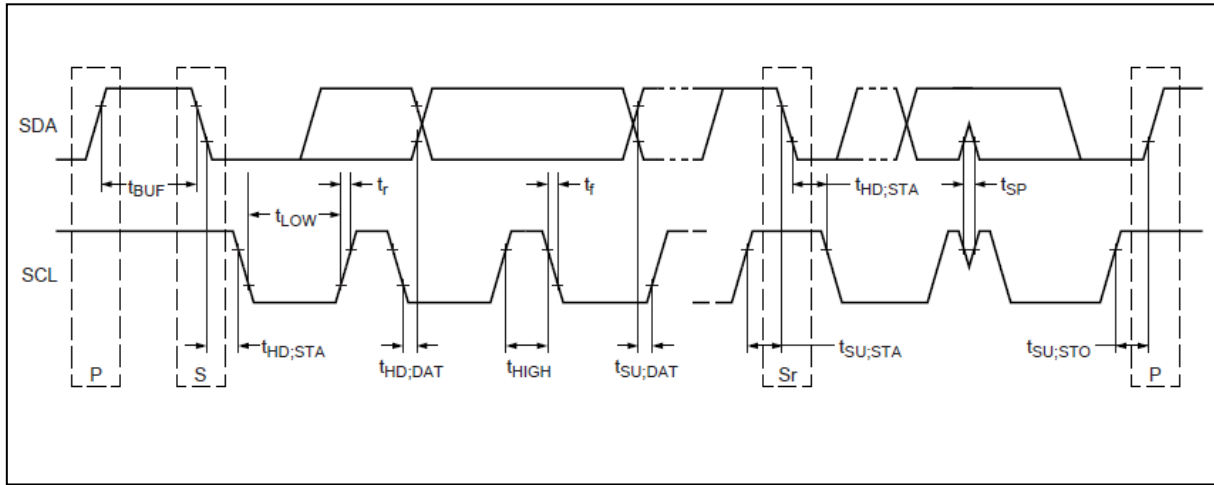

9. ORDERING INFORMATION

PART NUMBER	PACKAGE TYPE	REMARK
NCT5655Y	QFN24	Green Package (Halogen-free)
NCT5655W	TSSOP24	Green Package (Halogen-free)

10. TOP MARKING SPECIFICATION

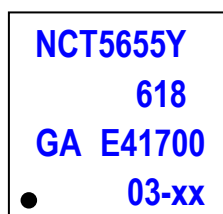

1st line: Part number **NCT5655Y**

2nd ~ 4th line: Tracking code

618: Packages assembled in Year 2016, week 18

G: Assembly house ID

A: IC version

E4170003-xx: Lot number



1st line: Nuvoton Logo

2nd line: Part number: **NCT5655W**

3rd line: Tracking code: **618 GA SA**

618: Packages assembled in Year 2015, week 18

G: Assembly house ID

A: IC version

SA: Internal use code

11. PACKAGE DIMENSION OUTLINE

11.1 QFN 24L 4x4mm², Thickness: 0.8mm, Pitch:0.50mm

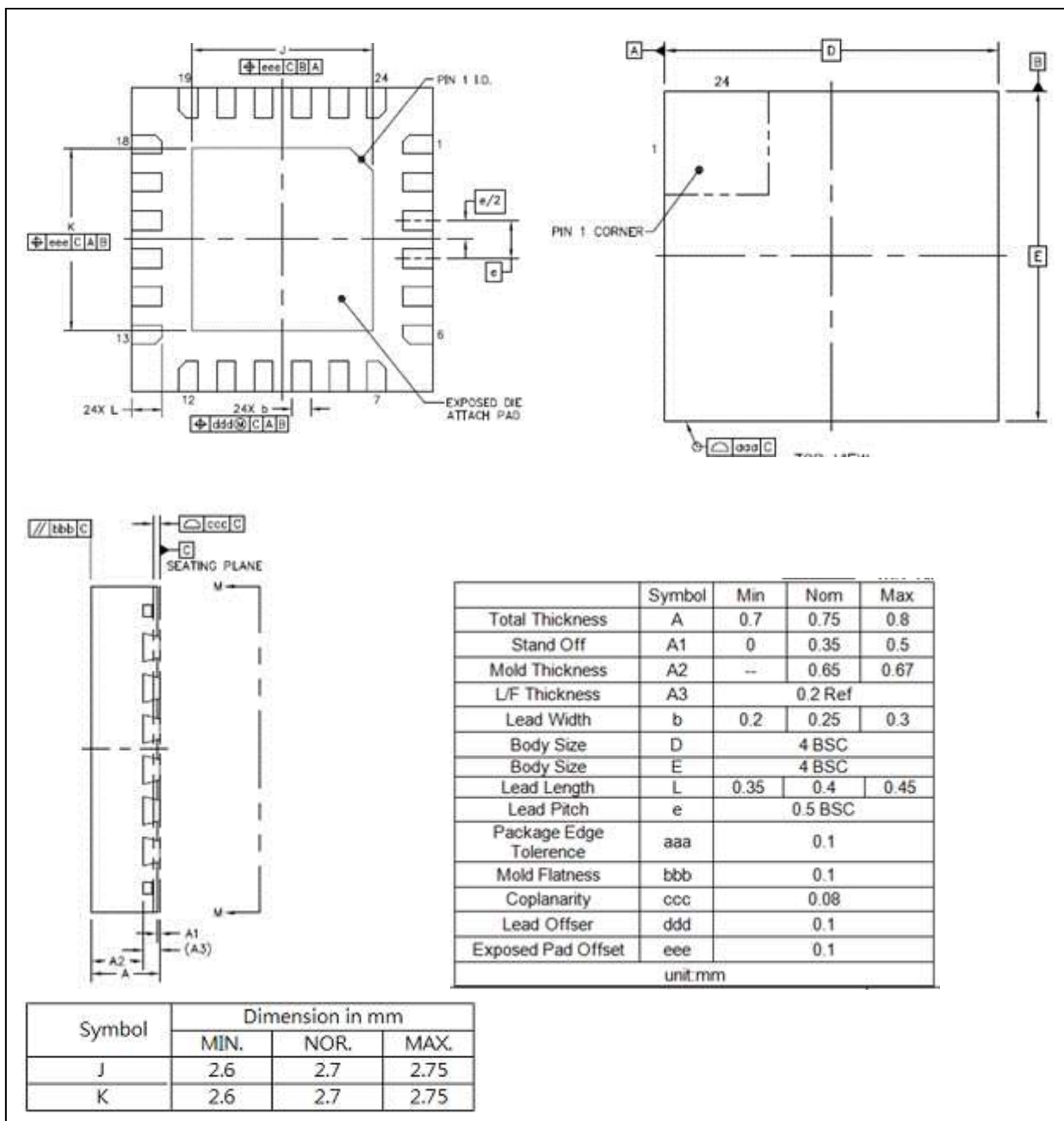

11.2 TSSOP 24L 4.4x7.8 mm²

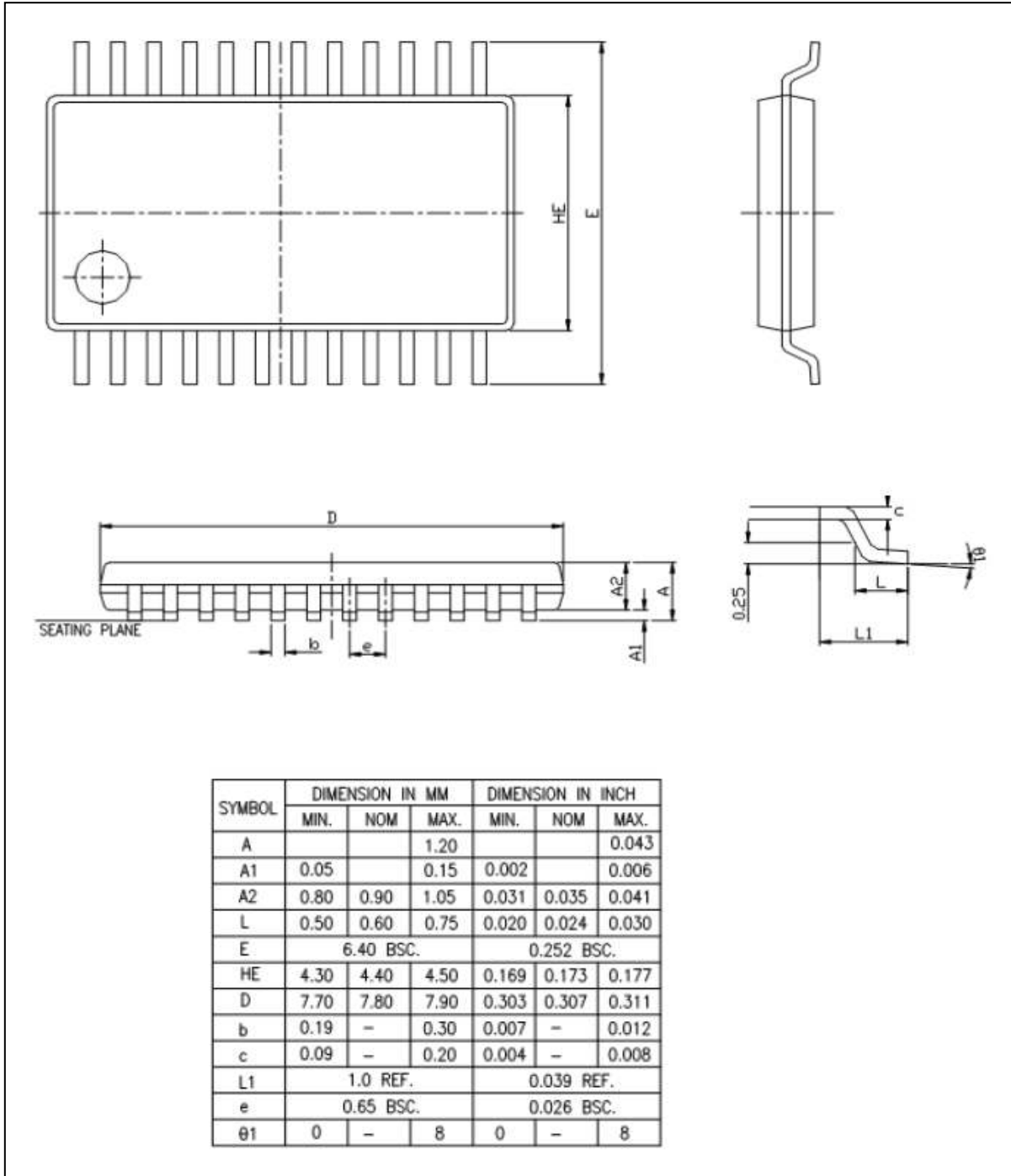

Important Notice

Nuvoton Products are neither intended nor warranted for usage in systems or equipment, any malfunction or failure of which may cause loss of human life, bodily injury or severe property damage. Such applications are deemed, “Insecure Usage”.

Insecure usage includes, but is not limited to: equipment for surgical implementation, atomic energy control instruments, airplane or spaceship instruments, the control or operation of dynamic, brake or safety systems designed for vehicular use, traffic signal instruments, all types of safety devices, and other applications intended to support or sustain life.

All Insecure Usage shall be made at customer’s risk, and in the event that third parties lay claims to Nuvoton as a result of customer’s Insecure Usage, customer shall indemnify the damages and liabilities thus incurred by Nuvoton.

*Please note that all data and specifications are subject to change without notice.
All the trademarks of products and companies mentioned in this datasheet belong to their respective owners.*