

REV.	DATE	ECR NO.	DESCRIPTION
NC	05/10/01	XXXXXX	INITIAL RELEASE
A	02/11/14	2698	CORRECT CABLE ENTRY I.D., UPDATE DRAWING FORMAT

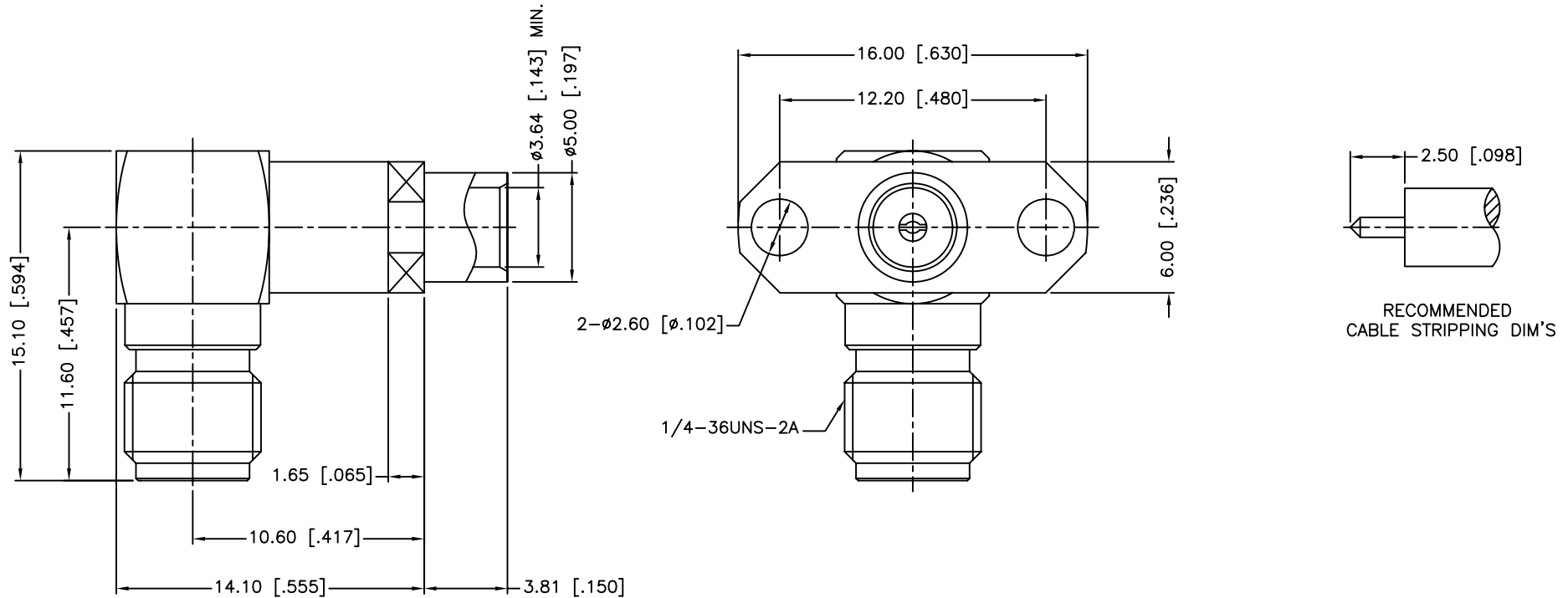

1. IMPEDANCE: 50 OHM
2. FREQUENCY RANGE: 0-18 GHZ
3. DIELECTRIC WITHSTANDING VOLTAGE: 1000 VRMS, MIN.
4. DURABILITY: 500 CYCLES MIN.
5. TEMPERATURE RANGE: -65°C TO +165°C

QTY	DESCRIPTION	MATERIAL	FINISH
7	COVER	BRASS	GOLD
6	SOLDER BODY	BRASS	GOLD
5	CONTACT PIN	BER. COPPER	GOLD
4	INSULATOR	PTFE	NATURAL
3	INSULATOR	PTFE	NATURAL
2	CONTACT PIN	BER. COPPER	GOLD
1	HOUSING WITH BODY	BRASS	GOLD

UNLESS OTHERWISE SPECIFIED DIMENSIONS ARE IN MILLIMETERS. DIMENSIONS IN [] ARE IN INCHES AND FOR CUSTOMER REFERENCE ONLY. UNLESS OTHERWISE SPECIFIED

TOLERANCES FOR MILLIMETERS ARE:
 <0.5 ± 0.05mm
 0.5 - 6mm ± 0.10mm
 6 - 30mm ± 0.20mm
 30 - 120mm ± 0.30mm
 ANGLES ± 1°

UNLESS OTHERWISE SPECIFIED TOLERANCES FOR INCHES ARE:
 <.020 ± 0.002"
 .020 - .236 ± 0.004"
 .236 - 1.180 ± 0.007"
 1.180 - 4.724 ± 0.012"
 ANGLES ± 1°

DO NOT SCALE DRAWING

APPROVALS		DATE
DRAWN	M.ZHANG	02/11/14
CHECKED		
ISSUED		
SHEET	1 OF 1	
CAD FILE	C:/CONNEX/132324.DWG	

Amphenol Connex			
PART DESCRIPTION SMA R/A PANEL SOLDER JACK - 2 HOLE FLANGE (FOR .141" SEMI RIGID CABLE)			
PART NO. 132324			
DWG. NO.	132324.DWG	REV.	A
SIZE	A	SCALE	NA