

引き出し方向  
PULL OUT DIRECTION

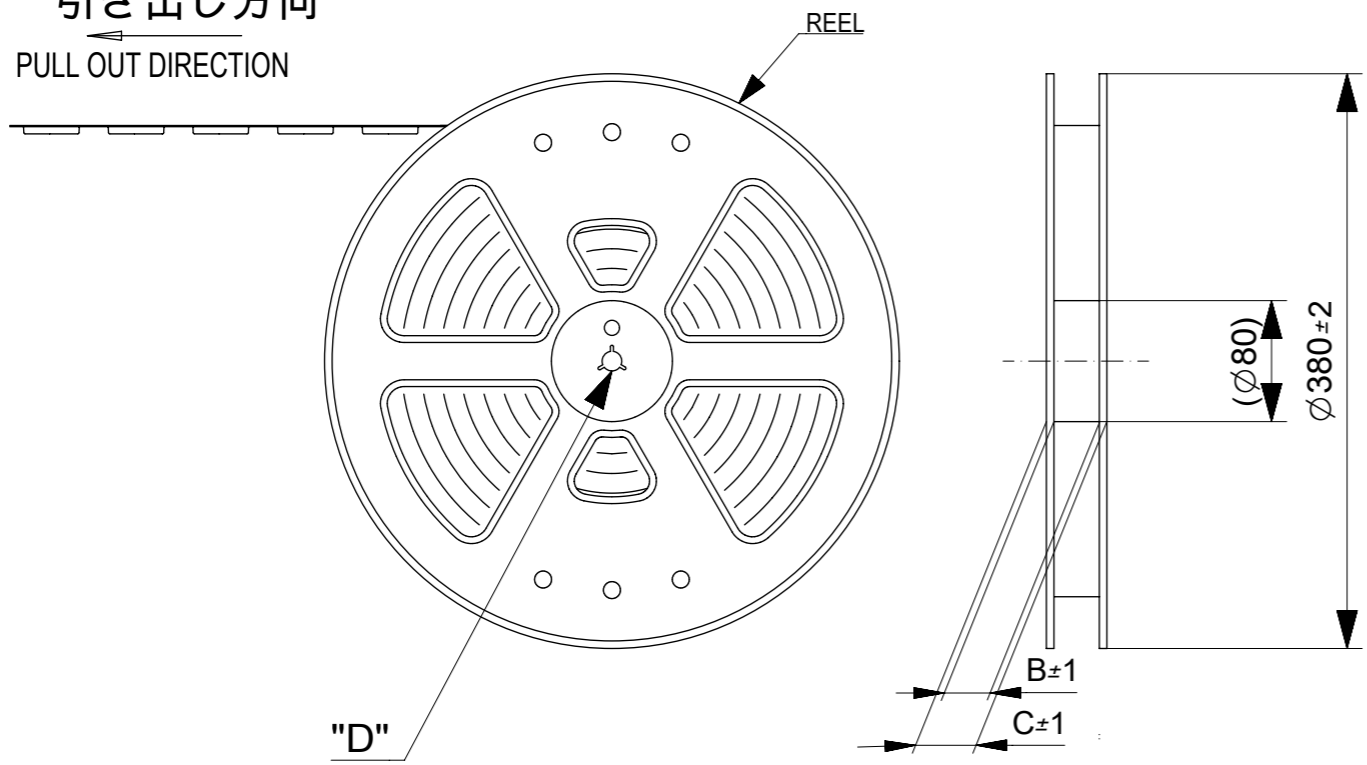

注記 NOTES

- 製品詳細寸法については製品単体図面を参照下さい。  
RE DETAILED DIMENSION, SEE PRODUCT DRAWING.
- 梱包数量：7000個 / リール  
NUMBER OF CONNECTORS : 7000 PCS/REEL.
- リードテープ長さ LEAD TAPE LENGTH.

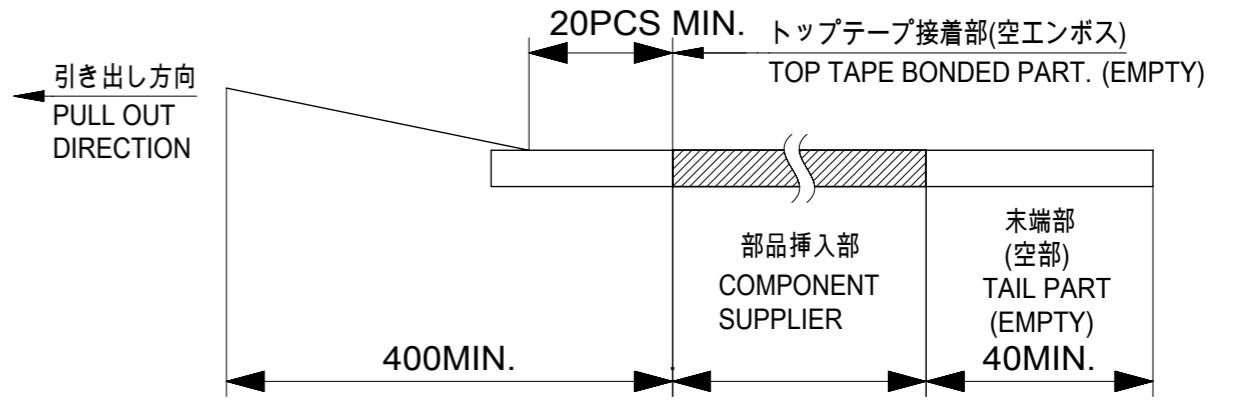

- カバーテープの剥離強度については、IEC60286-3に準拠。  
COVER TAPE PEEL FORCE IS DEFINED BY IEC60286-3.
- 材料 MATERIAL  
キャリアテープ(CARRIER TAPE) : ポリスチレン(POLYSTYRENE)  
トップテープ(TOP TAPE) : PET, OTHER  
リール(REEL) : ポリスチレン(PS) <リサイクル材を含む>  
POLYSTYRENE(PS) <RECYCLE MATERIAL CONTAINED >

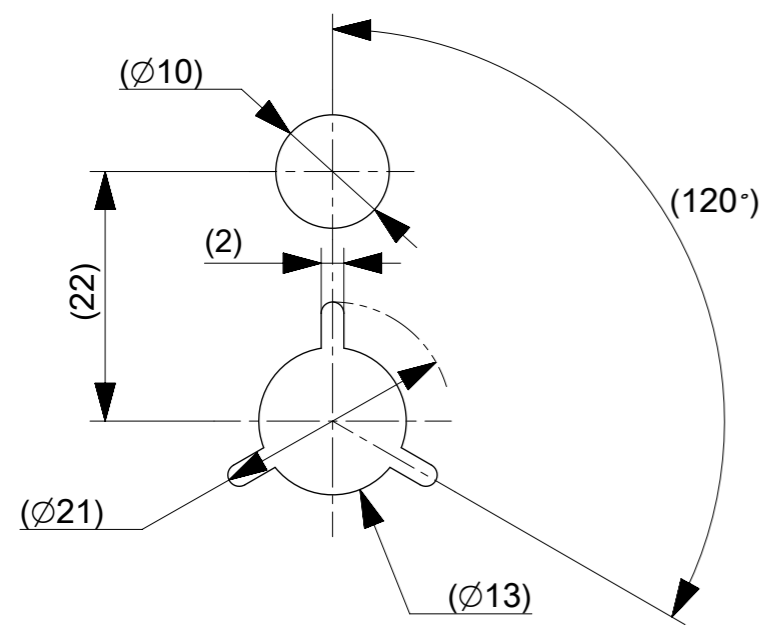

DETAIL "D"

MODEL No. 505550-\*\*20

THIS DRAWING CONTAINS INFORMATION THAT IS PROPRIETARY TO MOLEX ELECTRONIC TECHNOLOGIES, LLC AND SHOULD NOT BE USED WITHOUT WRITTEN PERMISSION									
DIMENSION UNITS		SCALE		CURRENT REV DESC:				<b>molex</b>	
mm		NTS							
GENERAL TOLERANCES (UNLESS SPECIFIED)				EC NO: 170751				0.4 BB CONN. HGT=0.8 REC ASSY EMBSTP PKG	
ANGULAR TOL ± 3.0 °				DRWN: JFURUKAWA 2018/01/11				PRODUCT CUSTOMER DRAWING	
4 PLACES ± 0.03				CHK'D: YNAITO 2018/01/18				DOCUMENT NUMBER	
3 PLACES ± 0.03				APPR: TKUSUHARA01 2018/01/18				5055500000	
2 PLACES ± 0.05				INITIAL REVISION:				DOC TYPE	
1 PLACE ± 0.1				DRWN: JFURUKAWA 2017/04/06				PSD	
0 PLACES ± 0.2				APPR: TKUSUHARA01 2017/04/14				DOC PART	
DRAFT WHERE APPLICABLE MUST REMAIN WITHIN DIMENSIONS				THIRD ANGLE PROJECTION		DRAWING		REVISION	
				A3-SIZE		SERIES		C	
				505550		MATERIAL NUMBER		SHEET NUMBER	
				SEE CHART		CUSTOMER		1 OF 3	
				GENERAL					

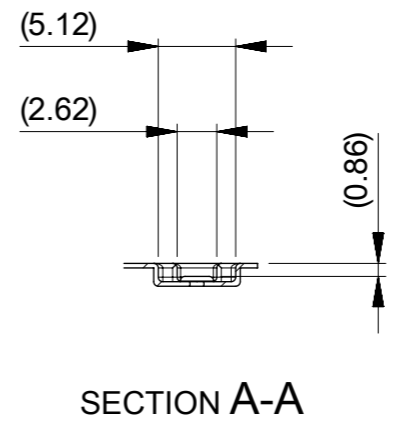
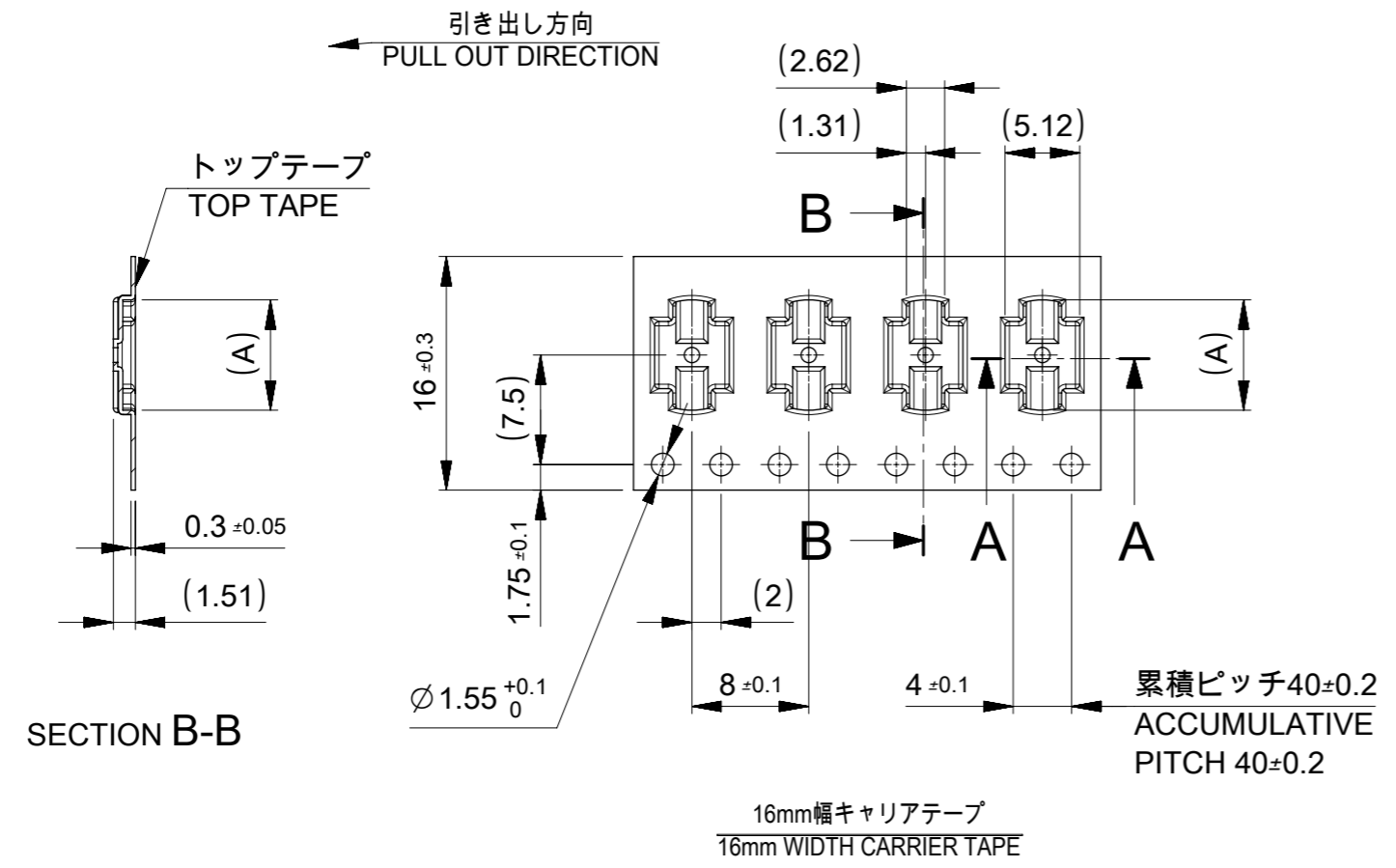

16	21.4	17.4	7.56	5055502420	24
			6.76	5055502020	20
			5.96	5055501620	16
			4.76	5055501020	10
キャリアテープ幅 CARRIER TAPE WIDTH		C	B	(A)	MATERIAL NO. CKT.
					MODEL NO. 505550-**20

THIS DRAWING CONTAINS INFORMATION THAT IS PROPRIETARY TO MOLEX ELECTRONIC TECHNOLOGIES, LLC AND SHOULD NOT BE USED WITHOUT WRITTEN PERMISSION

DIMENSION UNITS mm	SCALE NTS	CURRENT REV DESC:		<b>molex</b>		
GENERAL TOLERANCES (UNLESS SPECIFIED)		EC NO: 170751				
ANGULAR TOL	± 3.0 °	DRWN: JFURUKAWA 2018/01/11		PRODUCT CUSTOMER DRAWING		
4 PLACES	± 0.03	CHK'D: YNAITO 2018/01/18		DOCUMENT NUMBER		
3 PLACES	± 0.03	APPR: TKUSUHARA01 2018/01/18		5055500000		
2 PLACES	± 0.05	INITIAL REVISION:		DOC TYPE	DOC PART	REVISION
1 PLACE	± 0.1	DRWN: JFURUKAWA 2017/04/06		PSD	000	C
0 PLACES	± 0.2	APPR: TKUSUHARA01 2017/04/14		SHEET NUMBER		
DRAFT WHERE APPLICABLE MUST REMAIN WITHIN DIMENSIONS		THIRD ANGLE PROJECTION	DRAWING	SERIES	MATERIAL NUMBER	CUSTOMER
			A3-SIZE	505550	SEE CHART	GENERAL

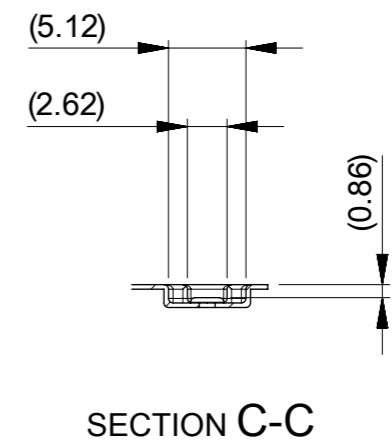
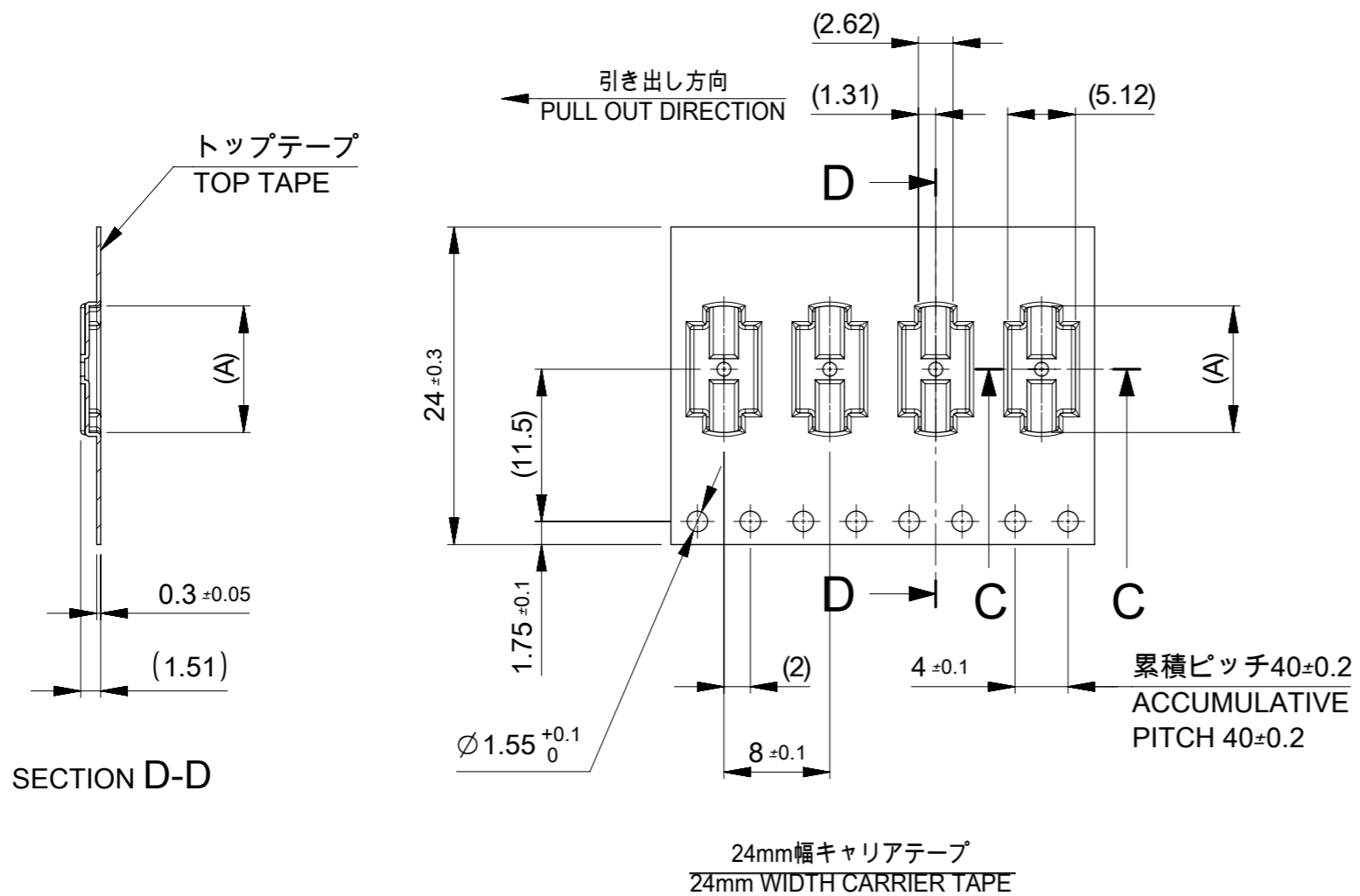

SECTION D-D

24	29.4	25.4	12.76	5055505020	50
			10.76	5055504020	40
			9.56	5055503420	34
			8.76	5055503020	30
キャリアテープ幅 CARRIER TAPE WIDTH			C	B	(A)
			MATERIAL NO.		CKT.
			MODEL NO. 505550-**20		

THIS DRAWING CONTAINS INFORMATION THAT IS PROPRIETARY TO MOLEX ELECTRONIC TECHNOLOGIES, LLC AND SHOULD NOT BE USED WITHOUT WRITTEN PERMISSION									
DIMENSION UNITS	SCALE	CURRENT REV DESC:							
mm	NTS								
GENERAL TOLERANCES (UNLESS SPECIFIED)						0.4 BB CONN. HGT=0.8 REC ASSY EMBSTP PKG			
ANGULAR TOL	± 3.0°					PRODUCT CUSTOMER DRAWING			
4 PLACES	± 0.03					DOCUMENT NUMBER			
3 PLACES	± 0.03					5055500000			
2 PLACES	± 0.05					DOC TYPE			
1 PLACE	± 0.1	PSD							
0 PLACES	± 0.2	DOC PART							
DRAFT WHERE APPLICABLE MUST REMAIN WITHIN DIMENSIONS		THIRD ANGLE PROJECTION		REVISION					
		DRAWING		C					
		A3-SIZE		SERIES					
		505550		MATERIAL NUMBER					
		SEE CHART		CUSTOMER					
		GENERAL		SHEET NUMBER					
		3 OF 3							

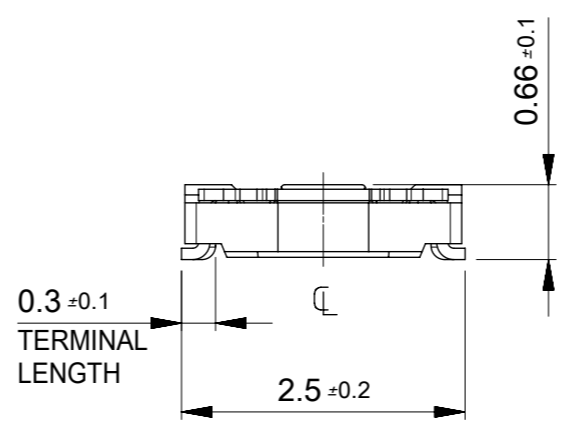
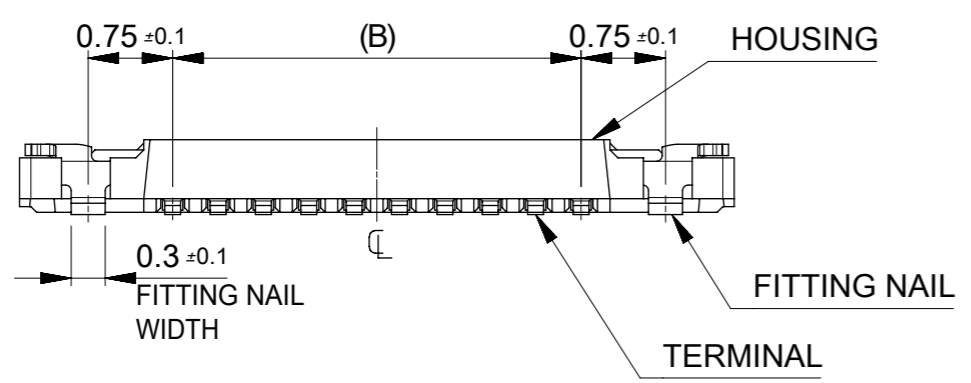
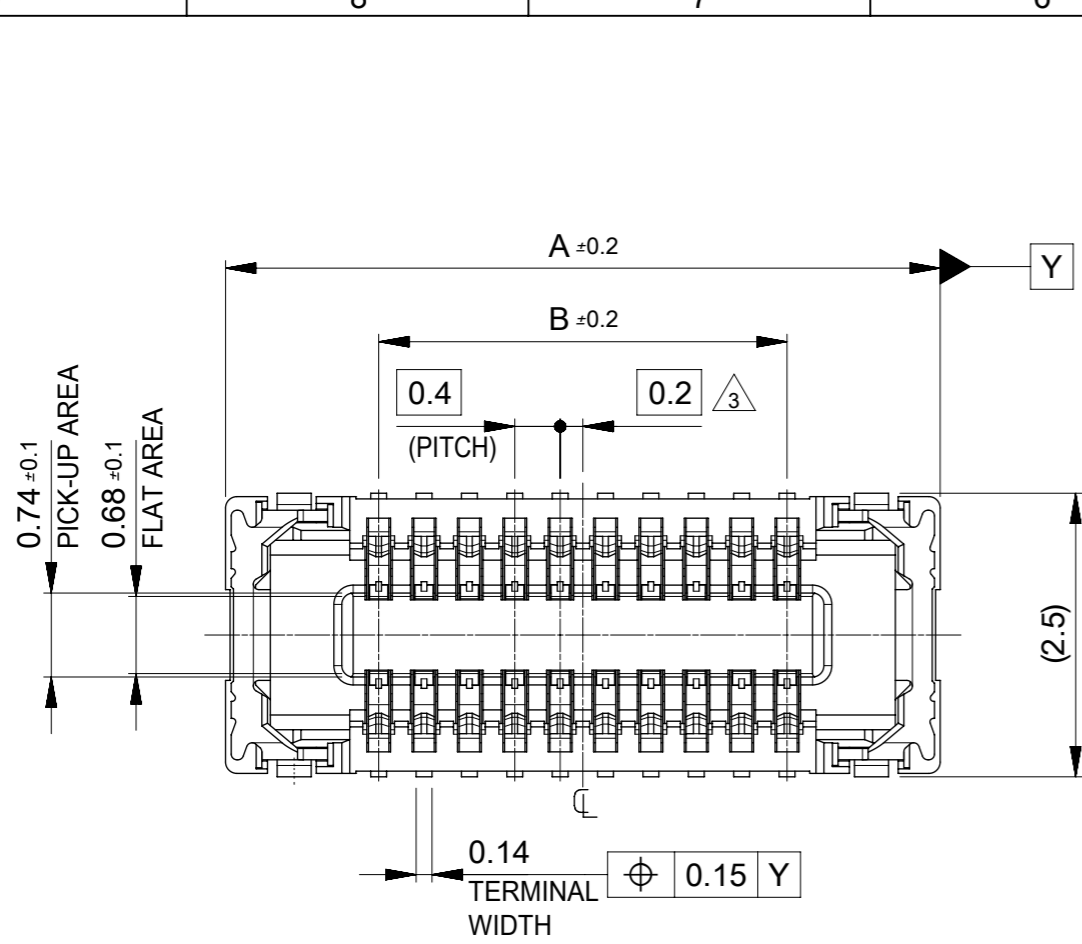

注記 NOTES

1. 使用材料 MATERIAL
  - ハウジング:液晶ポリマー(LCP) UL94V-0(黒)
  - HOUSING : LIQUID CRYSTAL POLYMER UL94V-0 (COLOR : BLACK)
  - ターミナル : 銅合金
  - TERMINAL : COPPER ALLOY
  - 金具 : SUS
  - FITTING NAIL : STAINLESS STEEL
2. メッキ仕様 PLATING
  - ターミナル TERMINAL
    - 金メッキ
    - GOLD
    - 下地メッキ : ニッケルメッキ
    - UNDER PLATING : NICKEL
  - ※コンタクト部とテール部はニッケルメッキによって分断されている金メッキです。
  - DIVIDE INTO PARTS THE GOLD PLATING OF THE CONTACT AND THE TAIL PART BY THE NICKEL PLATING.
- 金具 FITTING NAIL
  - 金メッキ(半田付部のみ)
  - GOLD (SOLDER TAIL ONLY)
  - 下地メッキ : ニッケルメッキ
  - UNDER PLATING : NICKEL
3. (全極数/2)=偶数の場合に適用。  
APPLY FOR (CIRCUIT/2)=EVEN.
4. 嵌合相手 : 505551 シリーズ  
MATE WITH : 505551 SERIES.
5. テール及び金具の平坦度は、0.08以下。  
TAIL AND FITTING NAIL COPLANARITY TO BE 0.08 MAXIMUM.
6. ELV and RoHS COMPLIANT

9.6	12.3	5055505020	50
7.6	10.3	5055504020	40
6.4	9.1	5055503420	34
5.6	8.3	5055503020	30
4.4	7.1	5055502420	24
3.6	6.3	5055502020	20
2.8	5.5	5055501620	16
1.6	4.3	5055501020	10
B	A	EMBOSSED PACKAGE	極数
		オーダー番号 ORDER No.	CIRCUITS
		CONNECTOR SERIES No. : 505550	

THIS DRAWING CONTAINS INFORMATION THAT IS PROPRIETARY TO MOLEX ELECTRONIC TECHNOLOGIES, LLC AND SHOULD NOT BE USED WITHOUT WRITTEN PERMISSION

DIMENSION UNITS	SCALE	CURRENT REV DESC:		<b>molex</b>		
mm	15:1					
GENERAL TOLERANCES (UNLESS SPECIFIED)		EC NO: 170751		0.4 BB CONN. HGT=0.8 W=2.5 REC ASSY		
ANGULAR TOL	± 3.0 °	DRWN: JFURUKAWA	2018/01/11	PRODUCT CUSTOMER DRAWING		
4 PLACES	± 0.03	CHK'D: YNAITO	2018/01/18	DOCUMENT NUMBER		
3 PLACES	± 0.03	APPR: TKUSUHARA01	2018/01/18	5055501000		
2 PLACES	± 0.05	INITIAL REVISION:		DOC TYPE	DOC PART	REVISION
1 PLACE	± 0.1	DRWN: JFURUKAWA	2017/08/03	PSD	001	B
0 PLACES	± 0.2	APPR: TKUSUHARA01	2017/08/31	SHEET NUMBER		
DRAFT WHERE APPLICABLE MUST REMAIN WITHIN DIMENSIONS		THIRD ANGLE PROJECTION	DRAWING	SERIES	MATERIAL NUMBER	CUSTOMER
			A3-SIZE	505550	SEE CHART	GENERAL

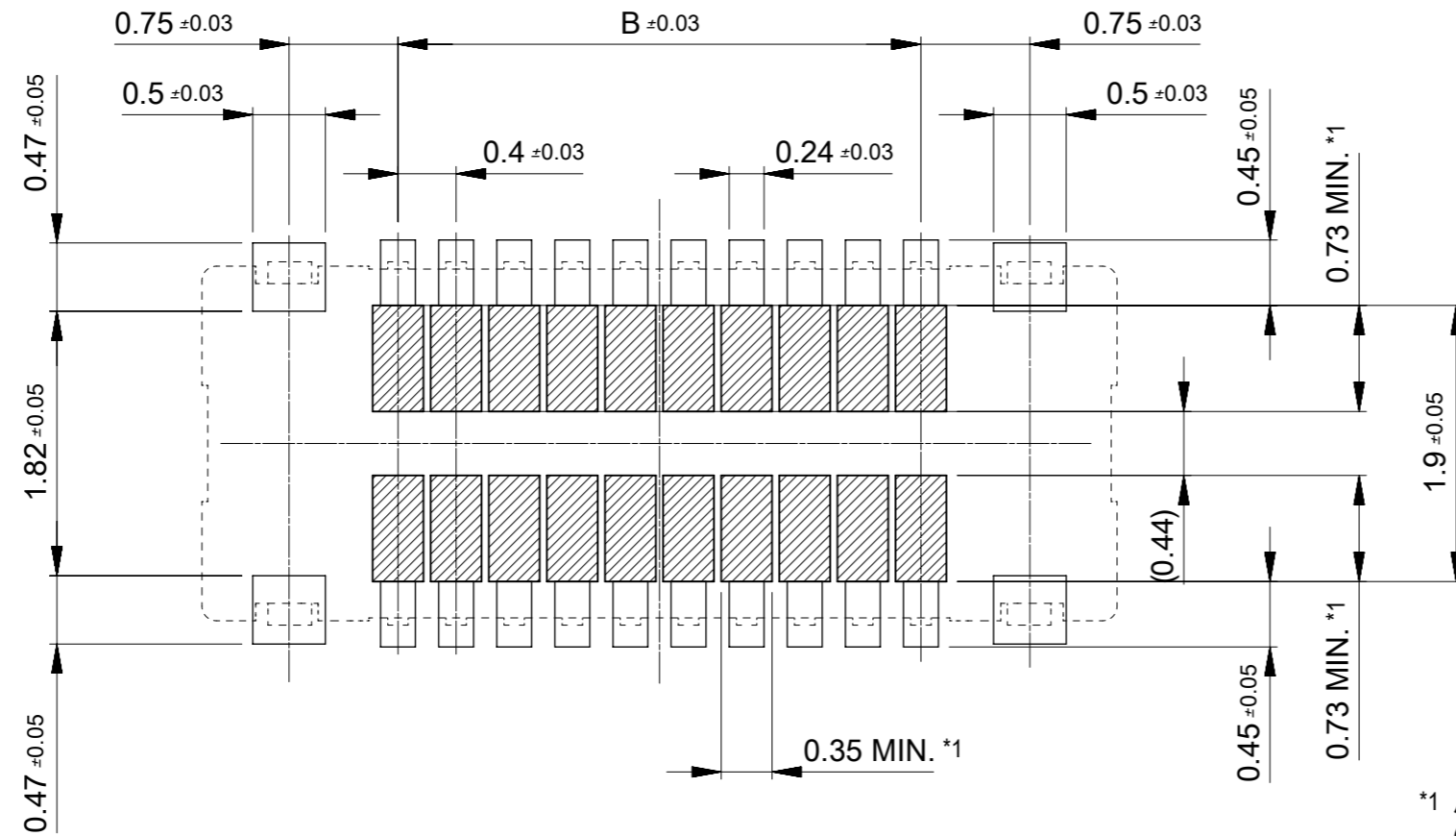

RECOMMENDED P.W.BOARD  
PATTERN LAYOUT

- \*1 パターン引き回し、および半田禁止エリア  
(当該箇所においては、これと接する回路以外の配線を禁止する。  
また、接する回路を配線する場合はレジストを施し、この部分に  
半田は無きこととする。)
- \*1 PROHIBITED AREA OF PATTERN WIRING AND SOLDER.  
(FOR EACH AREA, THE WIRING THAT TOUCHES ON THE SOLDER  
CAN BE ATTACHED, THEN COVERED WITH A FILM TO KEEP SOLDER OUT.)

THIS DRAWING CONTAINS INFORMATION THAT IS PROPRIETARY TO MOLEX ELECTRONIC TECHNOLOGIES, LLC AND SHOULD NOT BE USED WITHOUT WRITTEN PERMISSION									
DIMENSION UNITS		SCALE		CURRENT REV DESC:				<b>molex</b>	
mm		20:1							
GENERAL TOLERANCES (UNLESS SPECIFIED)									
ANGULAR TOL		± 3.0 °		EC NO: 170751					
4 PLACES		± 0.03		DRWN: JFURUKAWA		2018/01/11		0.4 BB CONN. HGT=0.8 W=2.5 REC ASSY	
3 PLACES		± 0.03		CHK'D: YNAITO		2018/01/18			
2 PLACES		± 0.05		APPR: TKUSUHARA01		2018/01/18		PRODUCT CUSTOMER DRAWING	
1 PLACE		± 0.1		INITIAL REVISION:					
0 PLACES		± 0.2		DRWN: JFURUKAWA		2017/08/03		DOCUMENT NUMBER	
				APPR: TKUSUHARA01		2017/08/31		5055501000	
DRAFT WHERE APPLICABLE MUST REMAIN WITHIN DIMENSIONS		THIRD ANGLE PROJECTION		DRAWING		SERIES		MATERIAL NUMBER	
				A3-SIZE		505550		SEE CHART	
				CUSTOMER		GENERAL		SHEET NUMBER	
								2 OF 2	