

REVISIONS			
REV	DESCRIPTION, ECN, EAR NO.	DATE	APP'D
A	NEW PROPOSAL	NOV30/22	KELVIN

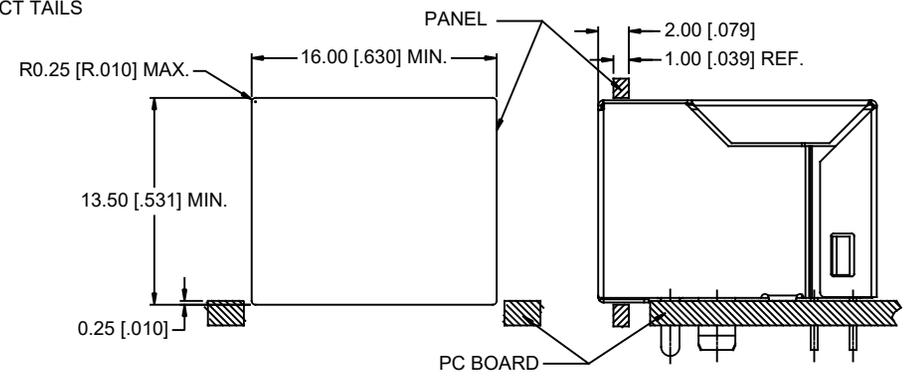
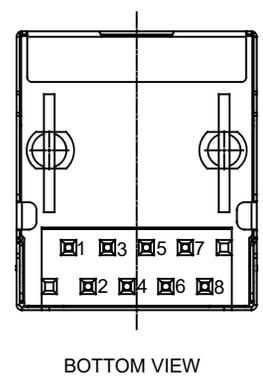
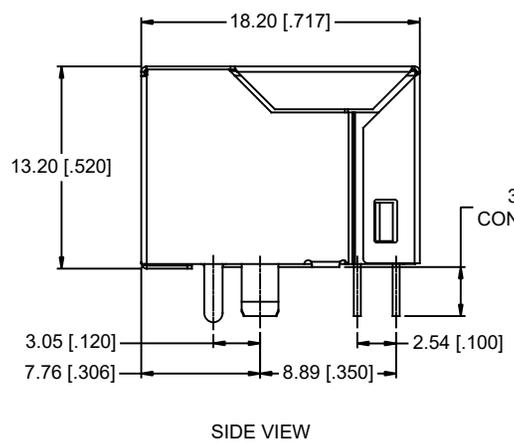
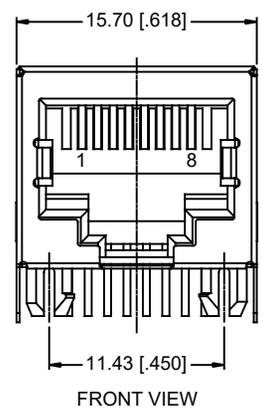

NOTES:

- MATERIALS:**
 CONTACTS: PHOSPHOR BRONZE, 0.46MM DIAMETER, PLATING: 3μ "[0.051 MICRONS] MIN. GOLD PLATING, 30μ "[0.762 MICRONS] MIN. NICKEL OVERALL.
 HOUSING: HIGH TEMPERATURE THERMOPLASTIC, FLAMMABILITY RATING UL 94V-0 COLOR - BLACK.
 SHIELD: BRASS WITH NICKEL PLATING
- MECHANICAL:**
 MATING FORCE: 5.0 LBS MAXIMUM
- ELECTRICAL:**
 CONTACT RESISTANCE: 20 MILLIOHMS MAXIMUM
 INSULATION RESISTANCE: 500 MEGOHMS MINIMUM
 CURRENT RATING: 1.5 AMPS
 VOLTAGE RATING: 125 VOLTS AC
- ENVIRONMENTAL:**
 STORAGE TEMPERATURE: -40°C TO +85°C
- RECOMMENDED SOLDERING TEMPERATURE:**
 WAVE SOLDERING PEAKED AT 260°C FOR 5 TO 8 SECONDS,
 OR REFLOW SOLDERING PEAKED AT 260°C FOR 10 SECONDS MAXIMUM.

AMPHENOL PART NUMBER: RJE09-188-4511-C

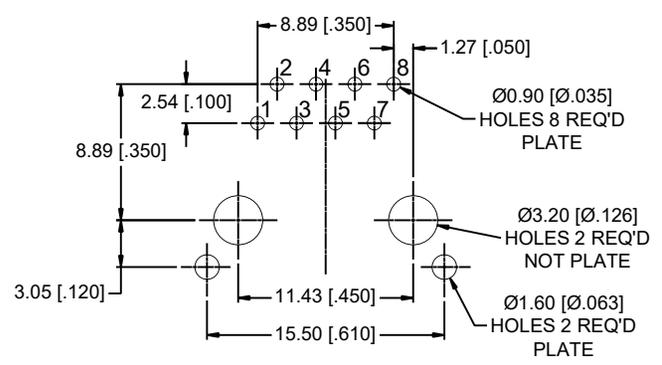

UNLESS SPECIFIED OTHERWISE	DRAWN RONNIE.C	NOV30/22
PRIMARY UNITS MILLIMETERS	CHECKED KELVIN.T	NOV30/22
SECONDARY INCHES	M.E. APP'D	
REFERENCE IN PARENTHESES	Q.A. APP'D	
GENERAL TOLERANCES	DWG APP'D	
1 DECIMAL PLACE ±0.30	ENG. REL. NO.	
2 DECIMAL PLACES ±0.20	REF.	
3 DECIMAL PLACES ±0.13		
ANGULAR DEGREES ±2.0°	THIRD ANGLE PROJECTION	DO NOT SCALE DRAWING

Amphenol Canada Corp. Commercial Products	
SINGLE PORT MODULAR JACK, TAB DOWN, 8 POSITION, 8 CONTACTS, SHIELDED -RoHS COMPLIANT	
DWG NO. P-RJE09-188-4511-C	REV A
CODE ID NO. 03554	DWG SIZE X SCALE N/A SHEET 1 OF 1