

THIS DRAWING IS UNPUBLISHED. RELEASED FOR PUBLICATION  
 © COPYRIGHT BY TYCO ELECTRONICS CORPORATION. ALL RIGHTS RESERVED.

LOC	DIST	REVISIONS			
P	LTR	DESCRIPTION	DATE	DWN	APVD
AF	50				
		D1	REVISED PER ECR-05-012061	17OCT05	MF GJ

- SPECIFICATIONS: MAGNET WIRE #34-#18 AWG .006 [0.16mm] - .040 [1.02mm] DIA COPPER.
- POCKET RECOMMENDATION: 1601431.
- MAINTAIN THICKNESS FOR THIS LENGTH AND COIN EDGES WITH NO BURRS.

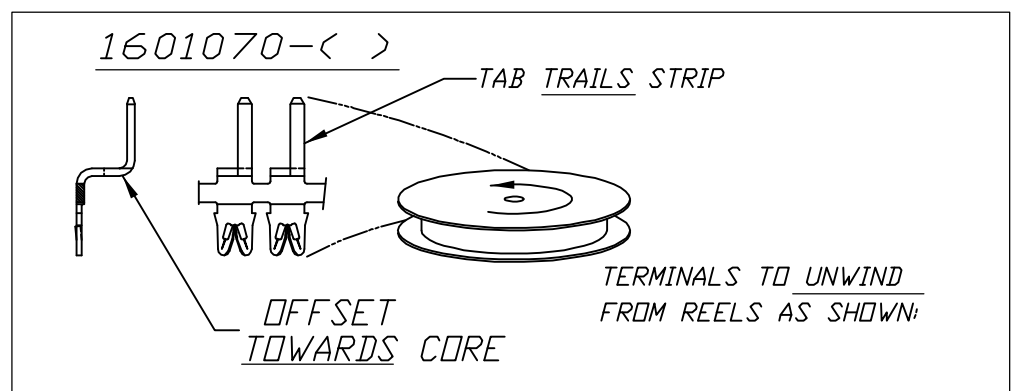
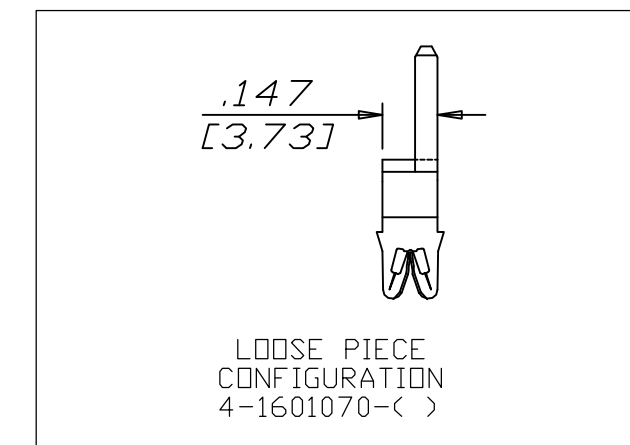
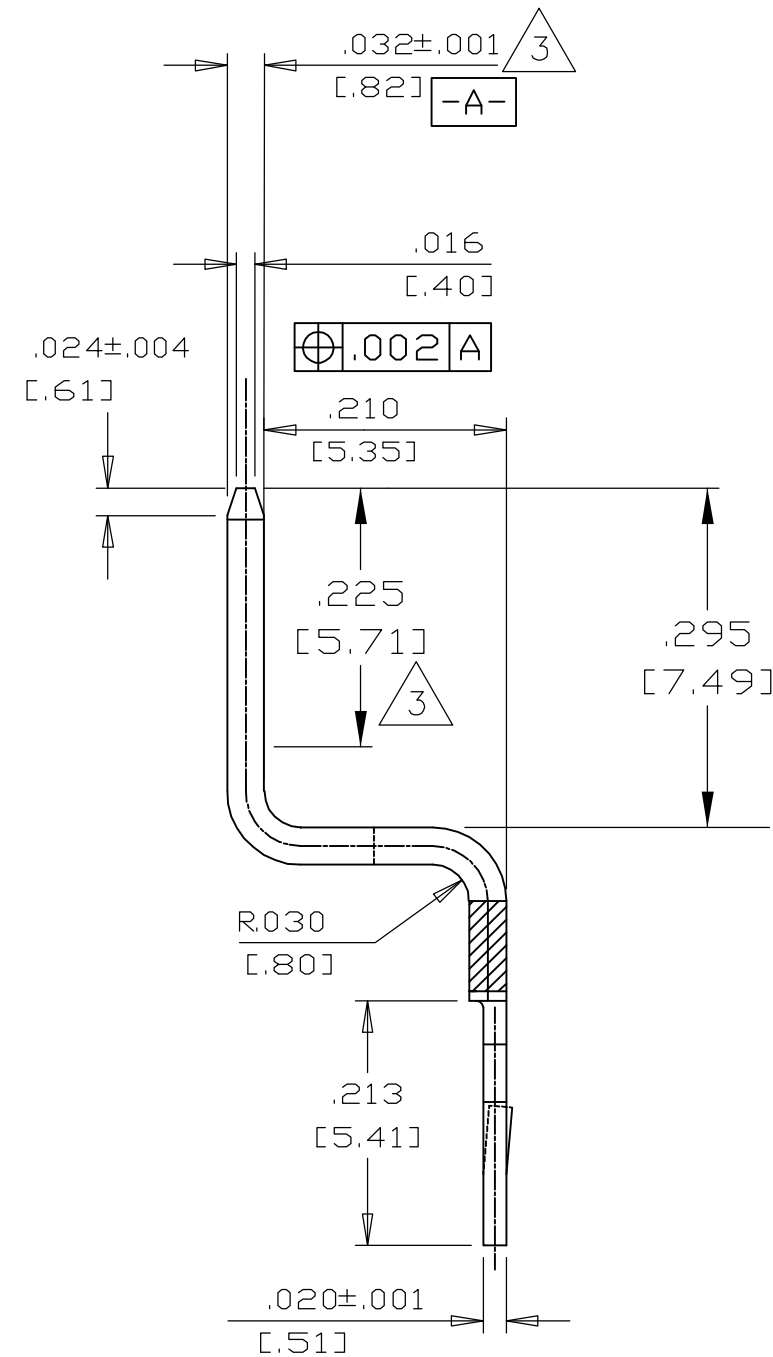
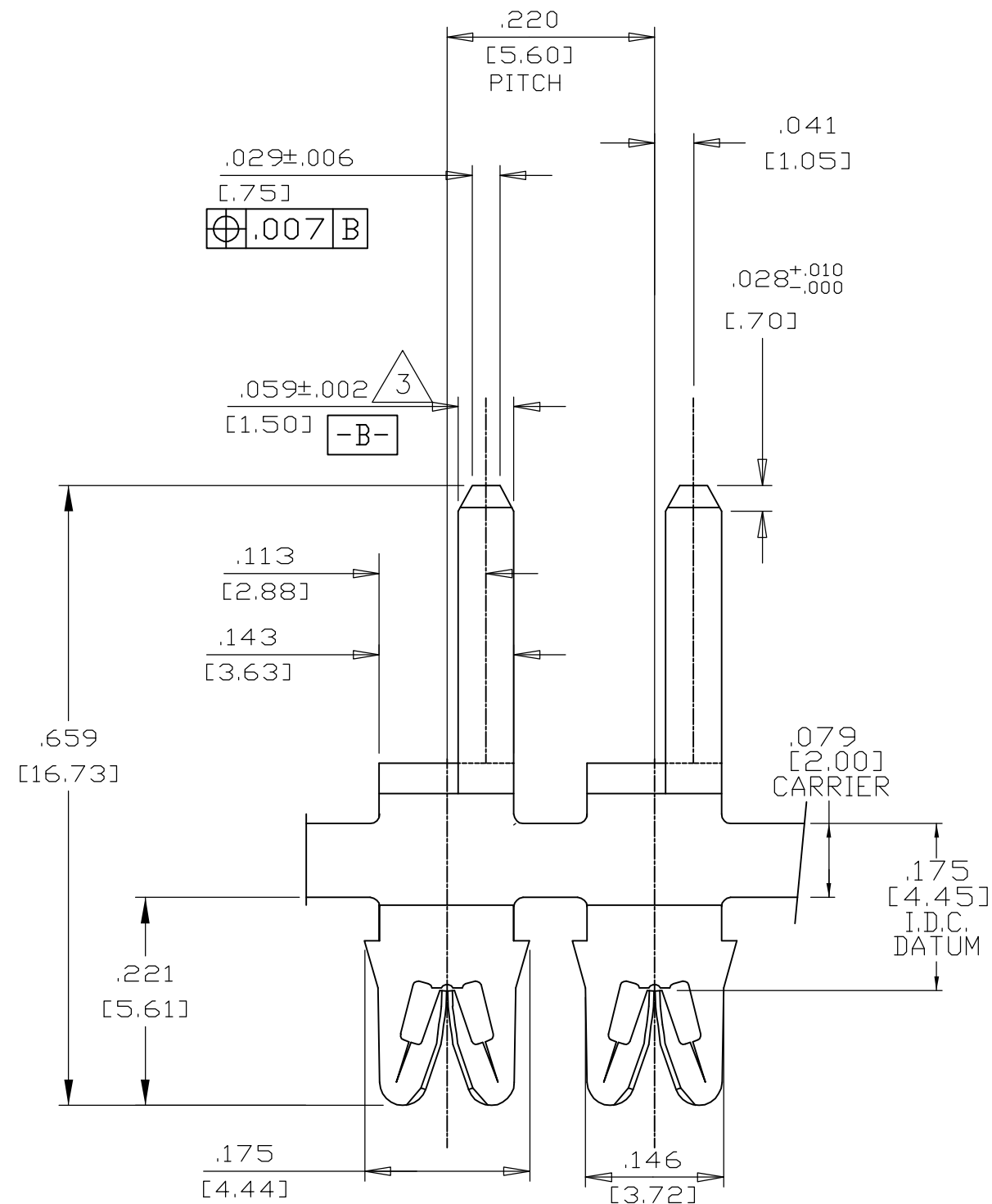
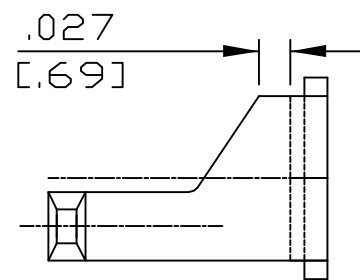

OBSOLETE

-	-	-
-	-	-
-	-	-
-	-	-
Pre-Tin Plate over Copper Underplate	131-138-014	2-1601070-2
Pre-Tin Plate over Copper Underplate	131-137-014	1601070-2
FINISH	REFERENCE PART NUMBER	TYCO PART NUMBER
THIS DRAWING IS A CONTROLLED DOCUMENT.	DWN 19FEB2002 MICHAEL S. FEHER	Tyco Electronics Corporation Harrisburg, PA 17105-3608
DIMENSIONS: INCHES	CHK 14FEB2002 KURT A. RANDOLPH	
TOLERANCES UNLESS OTHERWISE SPECIFIED:	APVD 14FEB2002 KURT A. RANDOLPH	NAME
0 PLC ± -	PRODUCT SPEC	BENT SIAMEZE TERMINAL
1 PLC ± -	APPLICATION SPEC	-
2 PLC ± .01[0.25]	408-2085	-
3 PLC ± .005[0.13]	408-8629	SIZE CAGE CODE DRAWING NO
4 PLC ± -	WEIGHT	A2 00779 C=1601070
ANGLES ± 2'	FINISH	RESTRICTED TO
MATERIAL BRASS, 1/2 HARD	SEE TABLE	SCALE 1:1 SHEET 1 of 1 REV D1
CUSTOMER DRAWING		