

AMC7812EVM-PDK User's Guide

This user's guide describes the characteristics, operation, and use of the AMC7812 evaluation module (EVM). This user's guide also discusses the proper setup and configuration of software and hardware and reviews various aspects of program operation. A complete circuit description, schematic diagram, and bill of materials are also included.

Contents

1	Overview	3
2	AMC7812EVM Hardware Setup	4
3	AMC7812EVM Software Setup	7
4	AMC7812EVM Hardware Overview	9
5	AMC7812EVM Software Overview	13
6	AMC7812EVM Documentation	22

List of Figures

1	AMC7812EVM Hardware Setup	4
2	AMC7812 Test Board Block Diagram	4
3	SDM-USB-DIG Platform Block Diagram	6
4	AMC7812EVM Installer Directory	7
5	AMC7812EVM Install Path	8
6	Typical Hardware Connections on the AMC7812EVM	10
7	Confirmation of SDM-USB-DIG Platform Driver Installation	10
8	AMC7812EVM GUI Location	13
9	AMC7812EVM GUI – Power On	13
10	Software Reset Button	14
11	Low-Level Configuration Page	14
12	ADC Page	15
13	ADC Block Activation Sequence	15
14	ADC Channel MUX	15
15	ADC CH0 to CH3 Config	15
16	ADC External Ref Value	16
17	ADC Report Window	17
18	DAC Page	17
19	Program DAC Registers	17
20	DAC Gain Button	18
21	DAC External Ref Value	18
22	DAC Clear and Latch Settings	18
23	DAC Clear Triggers	18
24	ALARMS Page	19
25	Alarm LEDs	19
26	Alarm LEDs Activated	19
27	Alarm Control Registers	20
28	GPIO + Temp Page	20

29	Temperature Read	20
30	Threshold Limit Configuration	21
31	Temperature Conversion Rate	21
32	GPIO Page	21
33	GPIO Write/Read	21
34	AMC7812EVM Schematic (1 of 3)	22
35	AMC7812EVM Schematic (2 of 3)	23
36	AMC7812EVM Schematic (3 of 3)	24
37	AMC7812EVM PCB Components Layout.....	25

List of Tables

1	Contents of AMC7812EVM Kit.....	3
2	Related Documentation	3
3	J1 Signal Definition	5
4	Default Jumper Settings	9
5	AMC7812EVM Jumper and Shunt Resistor Settings.....	11
6	AMC7812EVM ADC Signal Connections	11
7	AMC7812EVM DAC Signal Connections	12
8	AMC7812EVM GPIO Signal Definition	12
9	Conversion Rates	16
10	Bill of Materials	26

1 Overview

This EVM features the AMC7812, a highly-integrated, low-power, complete analog monitoring and control solution that includes a 16-channel (12-bit) ADC, 12-channel (12-bit) DAC, eight GPIOs, and two remote/one local temperature sensor channels. The device also features input out-of-range alarms, and configurable I²C-compatible/SPI interface with 5-V/3-V logic.

1.1 AMC7812EVM Kit Contents

Table 1 details the contents of the EVM kit. Contact the Texas Instruments Product Information Center nearest you if any component is missing. TI highly recommends to check the TI website (www.ti.com) to verify that you have the latest versions of the related software.

Table 1. Contents of AMC7812EVM Kit⁽¹⁾

ITEM	QUANTITY
AMC7812EVM PCB evaluation board	1
SDM-USB-DIG platform PCB	1
USB extender cable	1

⁽¹⁾ The 24-V wall adapter is not included with the evaluation module (EVM). Optionally, a 24-V (750-mA) center-positive wall adapter can be separately purchased to interface to the onboard 2.1 x 5.5-mm DC jack. In the case that a wall adapter is not available, external terminal blocks are included, which can interface with external supplies.

1.2 Related Documentation from TI

The following document provides information regarding TI integrated circuits used in the assembly of the AMC7812EVM. This user's guide is available from the TI website, literature number [SBAU177](#). Newer revisions may be available from the TI website at www.ti.com, or call the TI Literature Response Center at (800) 477-8924 or the Product Information Center at (972) 644-5580. When ordering, identify the document by both title and literature number.

Table 2. Related Documentation

Document	Literature Number
AMC7812 Product Data Sheet	SBAS513
SDM-USB-DIG Platform User's Guide	SBOU136

2 AMC7812EVM Hardware Setup

This section provides the overall system setup for the EVM. A PC runs software that communicates with the SDM-USB-DIG platform, which generates the power and digital signals used to communicate with the EVM board. An optional +24-V wall supply can provide power through the J5 connector to provide power to on-board power regulators (LDOs) that regulate the analog and digital supplies. By default, on-board connectors are included on the EVM board for external supplies. [Figure 1](#) displays the system setup for the AMC7812EVM.

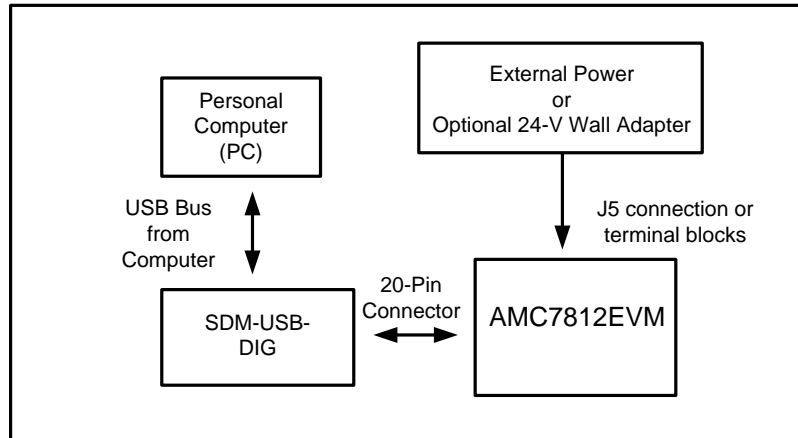

Figure 1. AMC7812EVM Hardware Setup

2.1 Theory of Operation for AMC7812 Hardware

[Figure 2](#) shows a block diagram of the AMC7812EVM test board. The EVM board provides testpoints for the supplies, internal reference, ground connections, SPI inputs, ADC inputs, and DAC outputs.

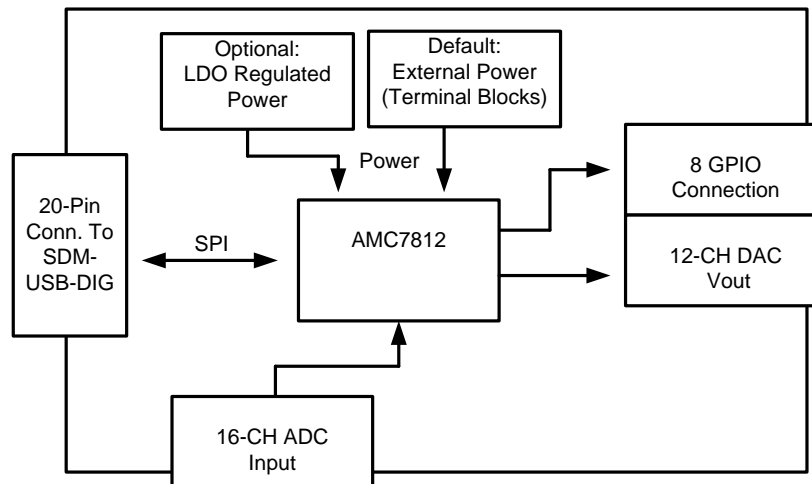

Figure 2. AMC7812 Test Board Block Diagram

2.2 Signal Definitions of J1 (20-Pin Male Connector Socket)

The AMC7812EVM includes a 20-pin connector socket used to communicate between the EVM and the SDM-USB-DIG platform. The pin out of the J1 connector is shown in [Table 3](#).

Table 3. J1 Signal Definition

Pin on J1	Signal	Description
1	SCL	I ² C clock signal (SCL)
2	DIG_GPIO2	GPIO – Control output or measure input
3	DIG_GPIO0	GPIO – Control output or measure input
4	DIG_GPIO3	GPIO – Control output or measure input
5	SDA	I ² C data signal (SDA)
6	DIG_GPIO4	GPIO – Control output or measure input
7	DIG_GPIO1	GPIO – Control output or measure input
8	DIG_GPIO5	GPIO – Control output or measure input
9	MOSI	SPI data output (MOSI)
10	DIG_GPIO6	GPIO – Control output or measure input
11	VDUT	Switchable DUT power supply: +3.3 V, +5 V, Hi-Z (disconnected). Note: When VDUT is Hi-Z all digital I/O are Hi-Z as well.
12	DIG_GPIO7	GPIO – Control output or measure input
13	SCLK	SPI clock signal (SCLK)
14	DIG_GPIO8	GPIO – Control output or measure input
15	GND	Power return (GND)
16	DIG_GPIO9	GPIO – Control output or measure input
17	CS	SPI chip select signal (/CS)
18	DIG_GPIO10	GPIO – Control output or measure input
19	MISO	SPI data input (MISO)
20	DIG_GPIO11	GPIO – Control output or measure input

2.3 Theory of Operation for SDM-USB-DIG Platform

The SDM-USB-DIG platform is a general-purpose data acquisition system that is used on select TI EVMs.

The core component of the platform is the MSP430F5528, an ultra-low power 16-bit MCU. The microcontroller receives information from the host PC and translates it into I²C, SPI, or other digital I/O patterns. The connected device (in this case, the AMC7812 device) connects to the I/O interface of the platform. During digital I/O transactions, the platform obtains information from the AMC7812 device and sends it to the host PC for interpretation. Figure 3 shows a block diagram of the platform.

To Computer and Power Supplies

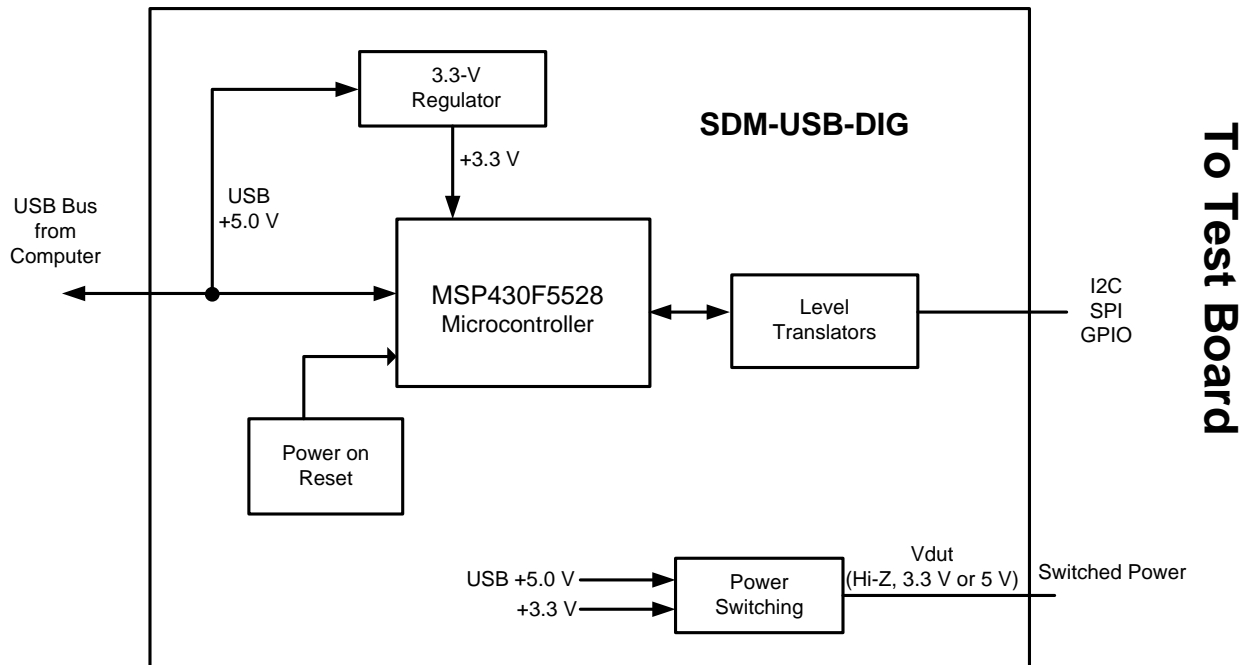

Figure 3. SDM-USB-DIG Platform Block Diagram

3 AMC7812EVM Software Setup

This section provides the procedure for EVM software installation.

3.1 Operating Systems for AMC7812EVM Software

The EVM software was tested on the Microsoft® Windows® XP and Windows 7 operating systems with the United States and European regional settings. The software should also be compatible with other Windows operating systems.

3.2 AMC7812EVM Software Installation

The software is available through the EVM product folder ([AMC7812EVM](#)) on the TI website. After the software is downloaded on the PC, navigate to the AMC7812EVM_Installer folder, and run the setup.exe file as shown in [Figure 4](#). When the software is launched, an installation dialog opens and prompts the user to select an installation directory. If left unchanged, the software location defaults to C:\Program Files (x86)\AMC7812EVM (Windows 7), as shown in [Figure 5](#). The software installation automatically copies the required drivers for the SDM-USB-DIG and AMC7812EVM to the PC. After the software is installed, connecting the SDM-USB-DIG to a USB port may launch a driver installation dialog. Choose the *Install this driver software anyway* option to continue with installation. (Note: On XP machines, choose to have the system automatically find the driver or software.)

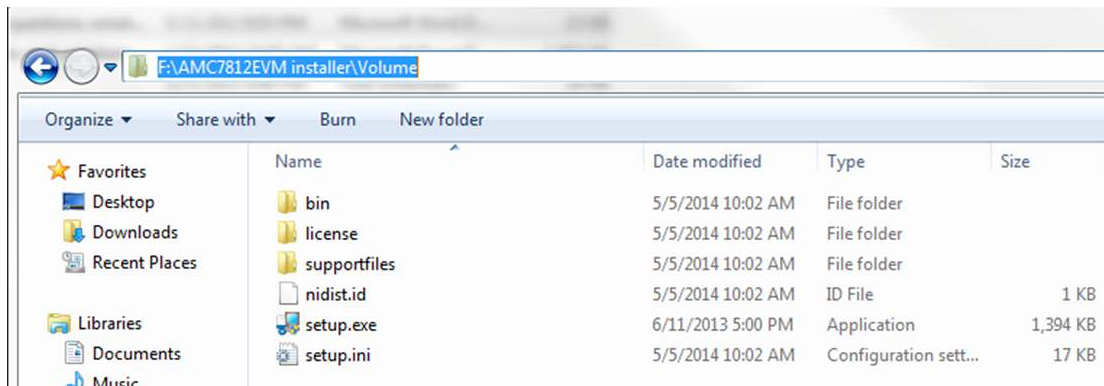

Figure 4. AMC7812EVM Installer Directory

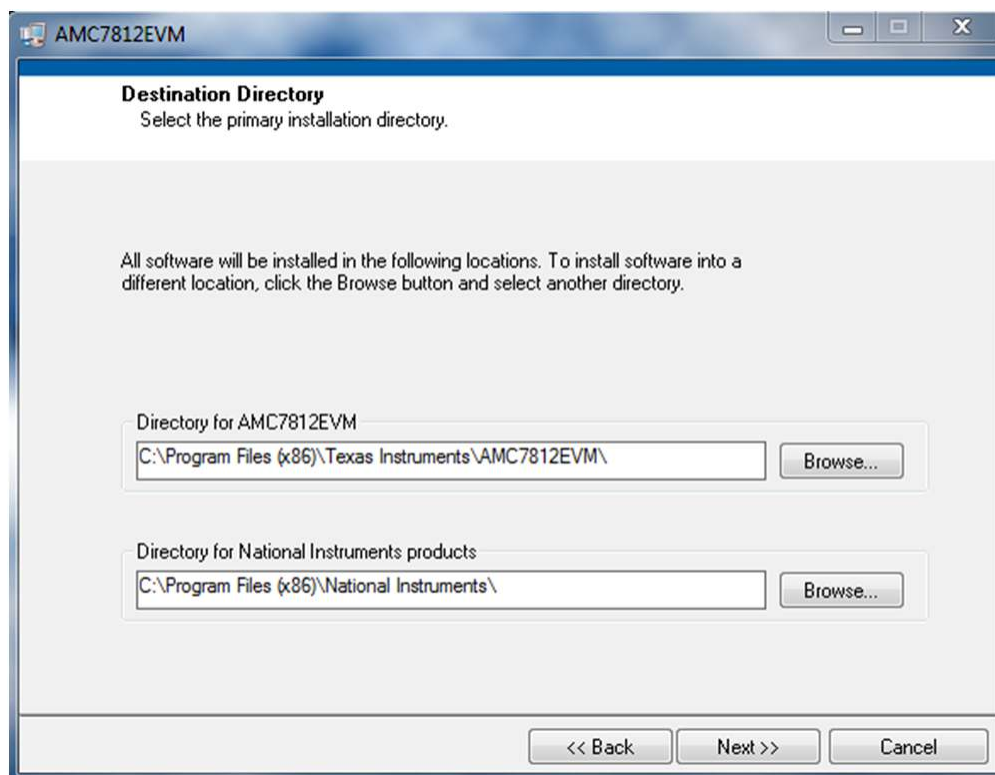

Figure 5. AMC7812EVM Install Path

4 AMC7812EVM Hardware Overview

The subsequent sections provide detailed information on the EVM hardware and jumper configuration settings. To use the +24-V wall supply, set the AV_{DD} and IOV_{DD} jumper connections to the default configuration listed in [Table 4](#). The table also displays the default configurations of all jumper connections on the AMC7812EVM. Connect the USB extender cable from the SDM-USB-DIG to the PC, and the +24-V wall adapter to the J5 terminal.

Table 4. Default Jumper Settings⁽¹⁾

Jumper	Default Position	Function
JP1	Shunt on 1-2	Selecting bus <ul style="list-style-type: none"> 1~2: (Default) SPI 2~3: (I2C)
JP2	Shunt on 1-2	Selecting DAC reference <ul style="list-style-type: none"> 1~2: (REF-OUT to REF-DAC) 3~4: (DACREF to REF-DAC) 5~6: (2.5 V REF to REF-DAC)
JP3	Shunt on 1-2	Selecting AV_{DD}/DV_{DD} voltage <ul style="list-style-type: none"> 1~2: Onboard 5-V supply 2~3: External supply
JP4	Shunt on 1-2	Selecting AV_{CC} voltage <ul style="list-style-type: none"> 1~2: (On board 14-V supply) 2~3: (External supply)
JP5	Shunt on 1-2	Selecting IOV_{DD} voltage <ul style="list-style-type: none"> 1~2: (On board VDUT) 2~3: (External supply)
JP6	Not installed	<ul style="list-style-type: none"> Installed: Onboard temp sensors Not installed: External temperature sensors
J7	Shunt on 5-6 Shunt on 7-8	Default OPA to GND for protection

⁽¹⁾ [Table 4](#) lists the default connections for the 24-V wall adapter connection. Refer to [Table 5](#) for external power connections.

4.1 Electrostatic Discharge (ESD) Caution

Many of the components on the AMC7812EVM are susceptible to damage by ESD. Observe proper ESD handling precautions when unpacking and handling the EVM, including the use of a grounded wrist strap at an approved ESD workstation.

4.2 Connecting the Hardware

To connect the SDM-USB-DIG to the EVM board, align and firmly connect the female and male ends of the 20-pin connectors (see [Figure 6](#)). Verify the connection is snug, as loose connections may cause intermittent operation.

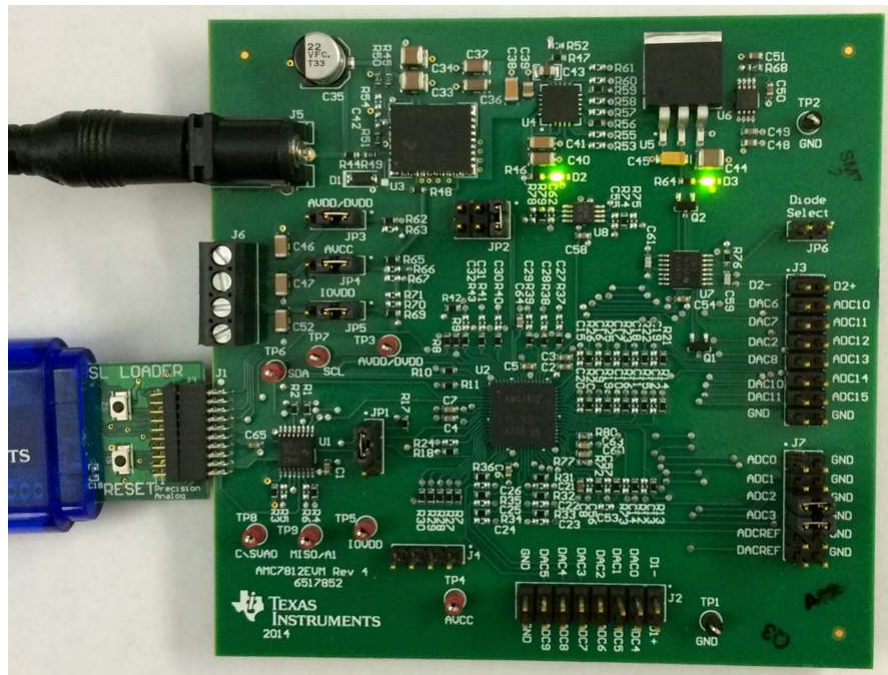

Figure 6. Typical Hardware Connections on the AMC7812EVM

4.3 Connecting the USB Cable to the SDM-USB-DIG

Figure 7 shows the typical response when connecting the SDM-USB-DIG platform to a USB port of a PC for the first time. The PC usually responds with a *Found New Hardware, USB Device* popup dialog window. The popup window then changes to *Found New Hardware, Virtual COM Port (CDC)*. This popup indicates that the device is ready for use. The CDC driver is used for communication between the SDM-USB-DIG and PC.

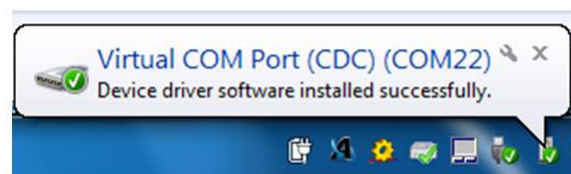

Figure 7. Confirmation of SDM-USB-DIG Platform Driver Installation

4.4 AMC7812EVM Power Configurations

This section describes the various power configurations that can be used by the EVM.

The AMC7812EVM provides onboard power conditioning to convert the 24-V supply into a 14-V, 5-V, and 3.3-V supply. Jumpers JP3 and JP5 allow the AV_{DD} and IOV_{DD} inputs to be configured to use these onboard supplies, or external supplies through the J6 terminal block. The AV_{CC} input is configured to use the onboard regulated supplies, but can be connected externally by populating the shunt resistors as shown in [Table 5](#).

Table 5. AMC7812EVM Jumper and Shunt Resistor Settings

Jumper	Default Position	Function
JP3	Shunt on 1-2	Selecting AV_{DD}/DV_{DD} voltage <ul style="list-style-type: none"> 1~2: Onboard 5-V supply 2~3: External supply
JP4	Shunt on 1-2	Selecting AV_{CC} voltage <ul style="list-style-type: none"> 1~2: (Onboard 14-V supply) 2~3: (External supply)
JP5	Shunt on 1-2	Selecting IOV_{DD} voltage <ul style="list-style-type: none"> 1~2: (Onboard VDUT) 2~3: External supply
R62, R63	R62 - 0- Ω shunt R63 - Not populated	<ul style="list-style-type: none"> (R62) +5-V LDO supply (default) (R63) +3.3-V LDO supply
R65, R66, R67	R65 - 0- Ω shunt R66 - Not populated R67 - Not populated	<ul style="list-style-type: none"> (R65) +14-V LDO supply (default) (R66) +5-V LDO supply (R67) +3.3-V LDO supply
R69, R70, R71	R69 - 0- Ω shunt R70 - Not populated R71 - Not populated	<ul style="list-style-type: none"> (R69) SDM-USB-DIG supply (default) (R70) +5-V LDO supply (R71) +3.3-V LDO supply

Additionally, IOV_{DD} is supplied by the SDM-USB-DIG but can be externally sourced by setting the JP5 jumper, and connecting the external source to the J6 terminal block.

4.5 ADC Signal Pins

The AMC7812 device contains 16 analog inputs, 12 of which are single-ended (ADC4 through ADC15) and have an input range of 0 to 5 V. The other four inputs (ADC0 through ADC3) can be configured as four single-ended inputs for two fully differential channels, depending on the setup of the ADC channel registers. These signal pins are connected to the J2, J3, and J7 connectors, which are described in [Table 6](#).

Table 6. AMC7812EVM ADC Signal Connections

Name	Connector	Description
ADC0	J7-1	ADC channel 0 input
ADC1	J7-3	ADC channel 1 input
ADC2 ⁽¹⁾	J7-5	ADC channel 2 input
ADC3 ⁽¹⁾	J7-7	ADC channel 3 input
ADC4	J2-4	ADC channel 4 input
ADC5	J2-6	ADC channel 5 input
ADC6	J2-8	ADC channel 6 input

⁽¹⁾ The AMC7812EVM includes two OPA2320 devices, which are configured to buffer the ADC2/ADC3 inputs. By default, the two inputs are connected to ground; this is accomplished by using the J7 shunts. [Table 4](#) shows the default configuration for the shunts. To use the channels, remove the shunts and apply the desired voltage input to ADC2 or ADC3.

Table 6. AMC7812EVM ADC Signal Connections (continued)

Name	Connector	Description
ADC7	J2-10	ADC channel 7 input
ADC8	J2-12	ADC channel 8 input
ADC9	J2-14	ADC channel 9 input
ADC10	J3-4	ADC channel 10 input
ADC11	J3-6	ADC channel 11 input
ADC12	J3-8	ADC channel 12 input
ADC13	J3-10	ADC channel 13 input
ADC14	J3-12	ADC channel 14 input
ADC15	J3-14	ADC channel 15 input

4.6 DAC Signal Pins

The 12 DAC voltage outputs of the AMC7812 device are accessible through the J2 and J3 connectors, as shown in [Table 4](#). The DAC voltage ranges are configurable through software to either 5 or 12.5 V.

Table 7. AMC7812EVM DAC Signal Connections

Name	Connector	Description
DACC0	J2-3	DAC-C0 output
DACC1	J2-5	DAC-C1 output
DACD2	J2-7	DAC-D2 output
DACD3	J2-9	DAC-D3 output
DACD4	J2-11	DAC-D4 output
DACD5	J2-13	DAC-D5 output
DACB6	J3-3	DAC-B6 output
DACB7	J3-5	DAC-B7 output
DACA8	J3-7	DAC-A8 output
DACA9	J3-9	DAC-A9 output
DACA10	J3-11	DAC-A10 output
DACA11	J3-13	DAC-A11 output

4.7 GPIO Signal Pins

The four GPIO signals on the EVM can be measured on the J4 header. [Table 8](#) provides a signal description of the J4 header.

Table 8. AMC7812EVM GPIO Signal Definition⁽¹⁾

Name	Connector	Description
GPIO0	J4-4	General-purpose I/O (GPIO0)
GPIO1	J4-3	General-purpose I/O (GPIO1)
GPIO2	J4-2	General-purpose I/O (GPIO2)
GPIO3	J4-1	General-purpose I/O (GPIO3)

⁽¹⁾ The remote sensor channels, D1+/D1– and D2+/D2–, can be configured as GPIO, if remote temperature sensors are not needed. Use a shunt to connect JP6 to remove the connection to the onboard remote temperature sensors.

5 AMC7812EVM Software Overview

This section discusses how to use the AMC7812EVM software.

5.1 Starting the AMC7812EVM Software

After the hardware connections are established and jumper settings configured, launch the software located in the AMC7812EVM folder of the Start *All Programs* menu, and select the *AMC7812EVM* icon.

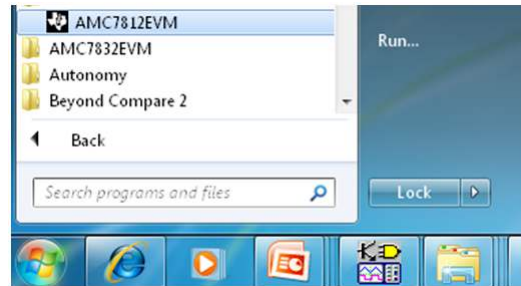

Figure 8. AMC7812EVM GUI Location

If the SDM-USB-DIG is properly connected to the AMC7812EVM, the GUI should automatically power on the system and display *CONNECTED: Power On* in the upper right area of the GUI (see Figure 9).

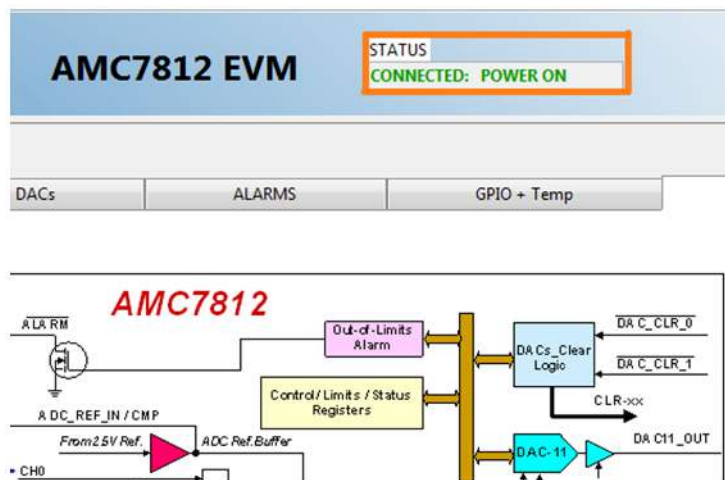

Figure 9. AMC7812EVM GUI – Power On

If the SDM-USB-DIG has a faulty connection, or is not connected at all, the GUI launches in simulation mode. In simulation mode, *NOT CONNECTED: Simulating* is displayed in the top-right area of the GUI. If this text appears while the SDM-USB-DIG device is connected, then unplug the SDM-USB-DIG and close the GUI. Reconnect the SDM-USB-DIG, and ensure that the connectors are correctly aligned. After doing those steps, verify the USB extender cable is properly connected to both the SDM-USB-DIG and PC, and relaunch the GUI. This connection issue can also occur if the CDC driver is installed incorrectly. The AMC7812EVM software may need to be reinstalled.

5.2 AMC7812EVM Software Features

The following subsections describe the functionality of each page of the AMC7812EVM GUI.

5.2.1 Software Reset

The AMC7812 *Software Reset* button, shown in Figure 10, resets the AMC7812 device and resets all registers to their default settings.

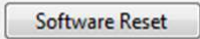
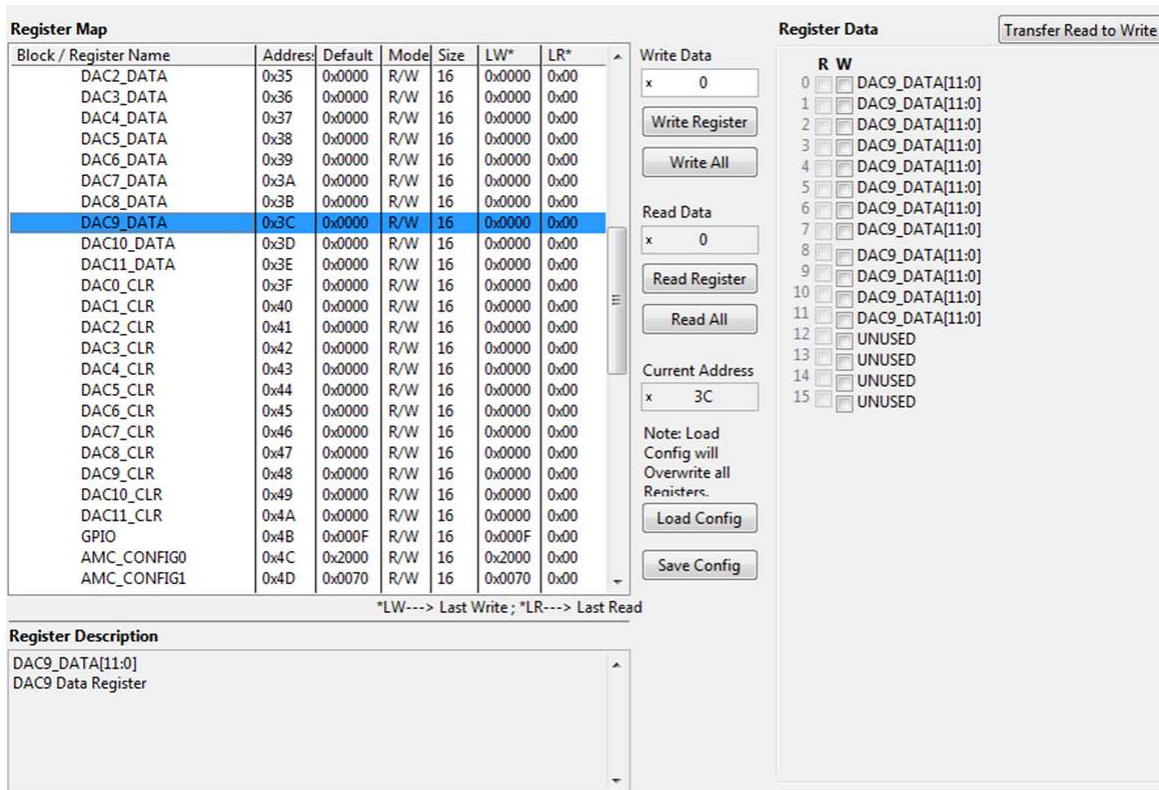

Figure 10. Software Reset Button

5.2.2 AMC7812EVM Low-Level Configuration Page

The AMC7812EVM features a register map page that allows access to low-level communication by directly writing to and reading from the AMC7812 registers. Selecting a register on the *Register Map* list presents a description of the values in that register and also displays information such as the register's address, default value, size, and current value. The register values can be modified through the Hex *Write Register* field, or set through Boolean checkboxes in the *Register Data* column, as displayed in Figure 11.



Block / Register Name	Address	Default	Mode	Size	LW*	LR*
DAC2_DATA	0x35	0x0000	R/W	16	0x0000	0x00
DAC3_DATA	0x36	0x0000	R/W	16	0x0000	0x00
DAC4_DATA	0x37	0x0000	R/W	16	0x0000	0x00
DAC5_DATA	0x38	0x0000	R/W	16	0x0000	0x00
DAC6_DATA	0x39	0x0000	R/W	16	0x0000	0x00
DAC7_DATA	0x3A	0x0000	R/W	16	0x0000	0x00
DAC8_DATA	0x3B	0x0000	R/W	16	0x0000	0x00
DAC9_DATA	0x3C	0x0000	R/W	16	0x0000	0x00
DAC10_DATA	0x3D	0x0000	R/W	16	0x0000	0x00
DAC11_DATA	0x3E	0x0000	R/W	16	0x0000	0x00
DAC0_CLR	0x3F	0x0000	R/W	16	0x0000	0x00
DAC1_CLR	0x40	0x0000	R/W	16	0x0000	0x00
DAC2_CLR	0x41	0x0000	R/W	16	0x0000	0x00
DAC3_CLR	0x42	0x0000	R/W	16	0x0000	0x00
DAC4_CLR	0x43	0x0000	R/W	16	0x0000	0x00
DAC5_CLR	0x44	0x0000	R/W	16	0x0000	0x00
DAC6_CLR	0x45	0x0000	R/W	16	0x0000	0x00
DAC7_CLR	0x46	0x0000	R/W	16	0x0000	0x00
DAC8_CLR	0x47	0x0000	R/W	16	0x0000	0x00
DAC9_CLR	0x48	0x0000	R/W	16	0x0000	0x00
DAC10_CLR	0x49	0x0000	R/W	16	0x0000	0x00
DAC11_CLR	0x4A	0x0000	R/W	16	0x0000	0x00
GPIO	0x4B	0x000F	R/W	16	0x000F	0x00
AMC_CONFIG0	0x4C	0x2000	R/W	16	0x2000	0x00
AMC_CONFIG1	0x4D	0x0070	R/W	16	0x0070	0x00

*LW--> Last Write; *LR--> Last Read

Register Description: DAC9_DATA[11:0] DAC9 Data Register

Register Data: DAC9_DATA[11:0] (bits 0-11) UNUSED (bits 12-15)

Write Data: x 0

Read Data: x 0

Current Address: x 3C

Buttons: Write Register, Write All, Read Register, Read All, Load Config, Save Config

Figure 11. Low-Level Configuration Page

This low-level configuration page also provides the option to save the register map settings as a configuration file, which is done by pressing the *Save Config* button. Additionally, the configuration files can be accessed through the *Load Config* button.

5.2.3 AMC7812EVM ADC Page

This page provides insight into the functionality of the AMC7812's 16-channel 12-bit ADC. The ADC block can be configured as 16 single-ended inputs (ADC0 to ADC15) or 2 differential inputs (ADC0 to ADC3) plus 12 single-ended (ADC4 to ADC15). The analog input range for the device can be selected as 0 V to Vref (2.5 V) or 0 V to 2 × Vref (5 V). Figure 12 displays the ADC Page.

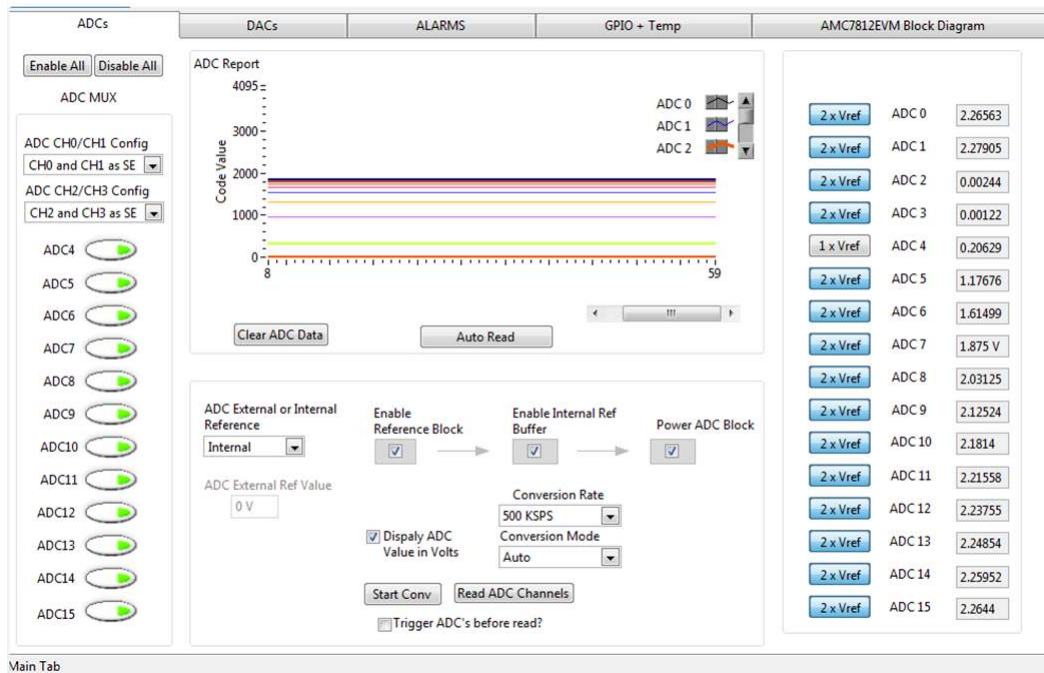

Figure 12. ADC Page

To completely activate the ADC block, the *Enable Reference Block* must be enabled, along with the *Enable Internal Reference Buffer* and *Power ADC Block*. Figure 13 shows this sequence.

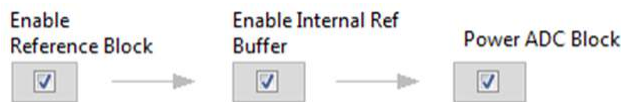

Figure 13. ADC Block Activation Sequence

After the device is configured, individual channels can be enabled by selecting their respective *ADC MUX* button, as shown in Figure 14.



Figure 14. ADC Channel MUX

CH0 to CH3 can be selected by using the dropdown menu and choosing various options such as differential mode, single-ended mode, and so forth, as shown in Figure 15.

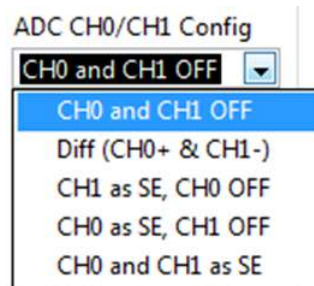

Figure 15. ADC CH0 to CH3 Config

The input range can be adjusted by clicking the button next to each ADC channel on the right-hand side of the page. Conversions can be triggered by pressing the *Start Conv* button or can be automatically triggered before every read by enabling the *Auto-Trigger* check box. The ADC data registers, displayed on the right side of the GUI, are updated with the converted results when the *Read ADC* button is pressed.

NOTE: The AMC7812EVM includes two OPA2320 devices, which are configured to buffer the ADC2/ADC3 inputs. By default, the two inputs are connected to ground, this is accomplished by using the J7 shunts. The default configuration for the shunts are located in [Table 4](#). To use the channels, remove the shunts and apply the desired voltage input to ADC2 or ADC3.

Most of the controls listed within the ADC image are used to setup the ADC configuration register. These include the *conversion rate* and *conversion mode* parameters, which are selectable through their respective dropdown list. The selectable conversion rates are listed in [Table 9](#).

Table 9. Conversion Rates

Conversion Rate	Throughput (ADC0–ADC11) (Single-Channel Auto Mode)
00	500 kSPS
01	250 kSPS
10	125 kSPS
11	62.5 kSPS

The conversion mode can be either *Auto* or *Direct* mode. In *Direct Mode*, the analog inputs, specified in the ADC channel registers, are converted sequentially one time. In *Auto Mode*, the analog inputs are converted sequentially and repeatedly. After a conversion is completed, the ADC multiplexer returns to the first channel and repeats the process.

The ADCs also have an option to use an *External* or *Internal* reference. Select this option by using a dropdown menu, then choosing the *External* or *Internal* option. When the *Internal* option is chosen, the *ADC External Ref Value* box is grayed out. But when an *External* reference option is selected, the *ADC External Ref Value* box becomes active and the value of external reference voltage can be entered in the box as shown in [Figure 16](#).

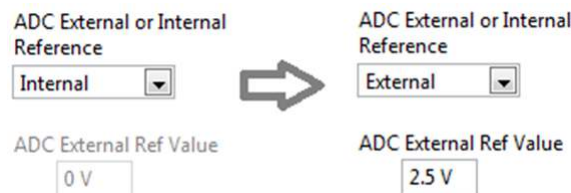

Figure 16. ADC External Ref Value

The *ADC Report* window displays the decimal value for each activated ADC channel. If the *Auto Read* button is pressed, the graph periodically updates with the new ADC value. To obtain new data, setup the device for either Auto mode or Direct mode. If in Direct mode, verify that the *Trigger ADCs before read?* button is enabled. To stop the periodic updates press the *Auto Read* button once again. [Figure 17](#) shows the *ADC Report* window. Additionally, the *Clear ADC Data* button clears the memory of the chart.

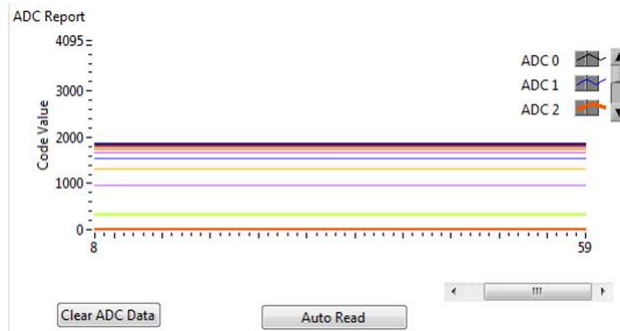

Figure 17. ADC Report Window

5.2.4 AMC7812EVM DAC Page

The DAC page gives the user an interface to observe and control the different data registers, modes, and configurations available for each individual DAC channel. The AMC7812 contains 12 DACs with 12 bits of resolution. The DACs can be used with an *Internal* (default) or *External* reference. To fully activate the DAC block, set the *Enable Reference Block*. To set the DAC channels individually, select their respective checkbox in the *Power DAC* column (see Figure 18).

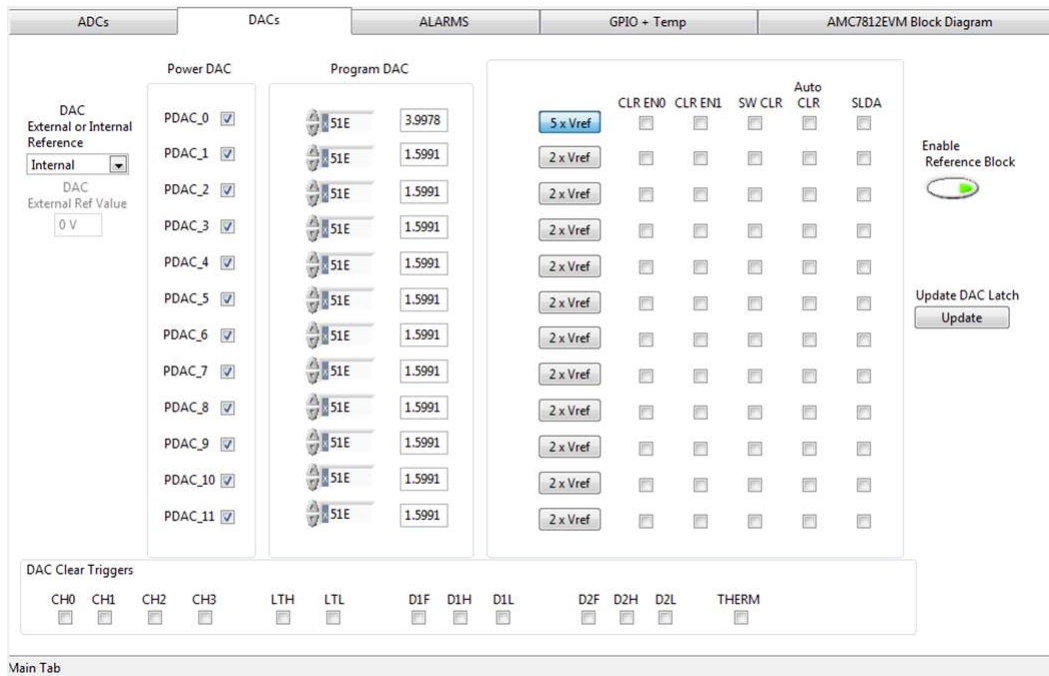

Figure 18. DAC Page

The DAC page also displays two input fields under the *Program DAC* column, shown in Figure 19.



Figure 19. Program DAC Registers

Either one of these windows can be programmed with the desired DAC output voltage or hexadecimal value. The default range upon startup is the 0 to 5 V (0 V to 2x Vref) range. The range can be changed to 0 to 12.5 V (5x Vref) by clicking the 2x Vref button, [Figure 20](#). The range button now displays 5x Vref and the program DAC value is also updated.



Figure 20. DAC Gain Button

The DAC page also has an option to use an *External* or *Internal* reference. Select this option by using a dropdown menu, then choosing *External* or *Internal* option. When the *Internal* option is chosen, the *DAC External Ref Value* box is grayed out. But when an *External* reference option is selected, the *DAC External Ref Value* box becomes active and the value of the external reference voltage can be entered in the box as shown in [Figure 21](#).

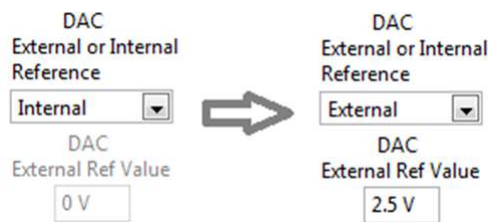

Figure 21. DAC External Ref Value

To the right of the *Program DAC* field are additional options that allow the user to configure each DAC for different events, as shown in [Figure 22](#). Starting from left to right, the *CLR EN0/ CLR EN1* checkbox allows the user to put the corresponding DAC in a clear state when the *DAC-CLR-0* or *DAC-CLR-1* pin goes low. The *SW CLR* checkbox forces the DAC into a clear state through software. *Auto CLR* forces the DAC to clear based on the *DAC Clear Triggers* located in the bottom of the page, [Figure 23](#). Last is the *SLDA* checkbox, which can be enabled for synchronous load; the registers are updated by pressing the *Update DAC Latch* button.



Figure 22. DAC Clear and Latch Settings



Figure 23. DAC Clear Triggers

5.2.5 AMC7812EVM ALARMS Page

The *ALARMS* page allows the user to access or observe the AM7812 registers and register bits related to common programmable settings and alarms of the AMC7812. [Figure 24](#) displays the *ALARMS* page of the AMC7812EVM.



Figure 24. ALARMS Page

The *ALARMS* page displays the name of each alarm, and provides information such as the *AMC7812 Local Temperature*, *D1 Temperature*, *D2 Temperature* status, and the *Analog Input (CH0-CH3) Out of Range* alarms. [Figure 25](#) shows these indicators.



Figure 25. Alarm LEDs

The false alarm protection setting for each alarm is also displayed; these settings allow the user to choose how many consecutive triggers must occur before the alarm is activated. Additionally, the bottom left of the GUI includes a checkbox function for enabling or disabling the alarm pin function and alarm latch settings.

Pressing the *Read Alarm Status* button enables the capture of the current state of the AMC7812, and if an alarm has occurred, it activates the corresponding LED, as seen in [Figure 26](#).

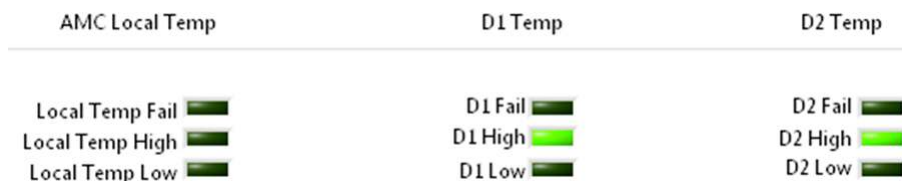

Figure 26. Alarm LEDs Activated

To associate the *ALARM* pin with an alarm event, select the appropriate event. [Figure 27](#) displays these checkboxes.



Figure 27. Alarm Control Registers

5.2.6 AMC7812EVM GPIO + Temp Page

The AMC7812EVM contains one internal *local* temperature sensor and two temperature measurement ports, D1 and D2, that are used for sensing temperatures from external remote locations. Figure 28 shows the *GPIO + Temp* page.

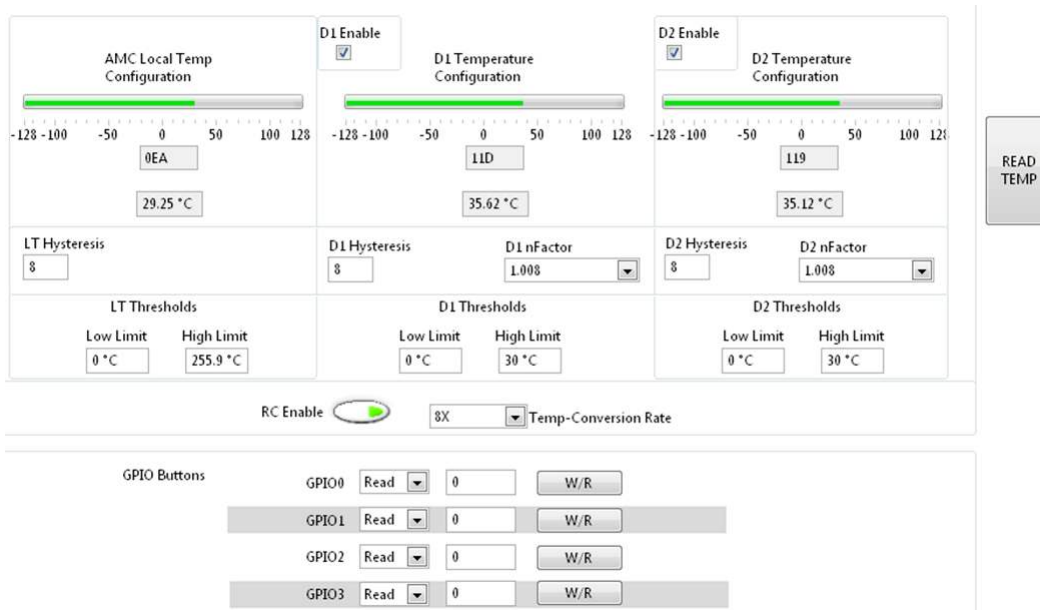

Figure 28. GPIO + Temp Page

The *GPIO + Temp* page allows the user to access or observe the AMC7812 registers related to the three temperature monitoring functions. Pressing the *READ TEMP* button enables a temperature conversion and updates the temperature value for all temperature functions in Celsius (°C) and hexadecimal. Additionally, these functions can be modified by adjusting the corresponding *Hysteresis* and *nFactor* values.

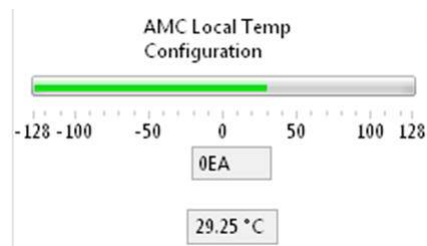

Figure 29. Temperature Read

The *ALARMS* page also ties into the functionality of the *GPIO + Temp* page, as this page determines the low and high threshold for all temperature configurations. Figure 30 shows where to program the limits by entering the desired Celsius values into the low or high limit fields.



Figure 30. Threshold Limit Configuration

The AMC7812 implements a technology to automatically cancel out the effect of series resistance caused by the length of wire attached to any external remote temperature sensor. The resistance cancellation can be disabled or enabled when the RC bit is cleared or set.

The conversion rate of the temperature data can also be set by adjusting the *Temp-Conversion Rate* dropdown, displayed in [Figure 31](#).



Figure 31. Temperature Conversion Rate

The *GPIO + Temp* page also features four (*GPIO0 through GPIO3*) general-purpose I/Os of the AMC7812 device as shown in [Figure 32](#).

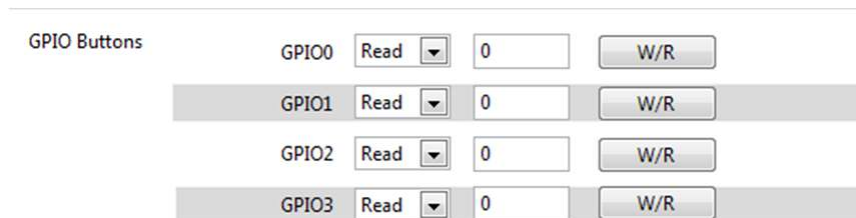

Figure 32. GPIO Page

Use the GPIO Block section of the GPIO tab, as shown in [Figure 33](#), to set the various GPIO functions. The dropdown menu defaults to general-purpose I/O. To perform a write or read, set the W/R Function pulldown to either Write or Read. The W/R value enables the user to input or observe the Boolean value of the GPIO register. Press the Generate Write/Read button to write to or read from the GPIO pin.

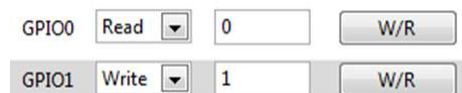

Figure 33. GPIO Write/Read

6 AMC7812EVM Documentation

This section contains the schematic diagrams and complete bill of materials for the AMC7812EVM. Documentation information for the SDM-USB-DIG platform can be found in the *SDM-USB-DIG Platform User's Guide*, [SBOU136](#), available at the TI website at [www.ti.com](#).

6.1 AMC7812EVM Board Schematic

Figure 34 through Figure 36 show the schematics for this EVM.

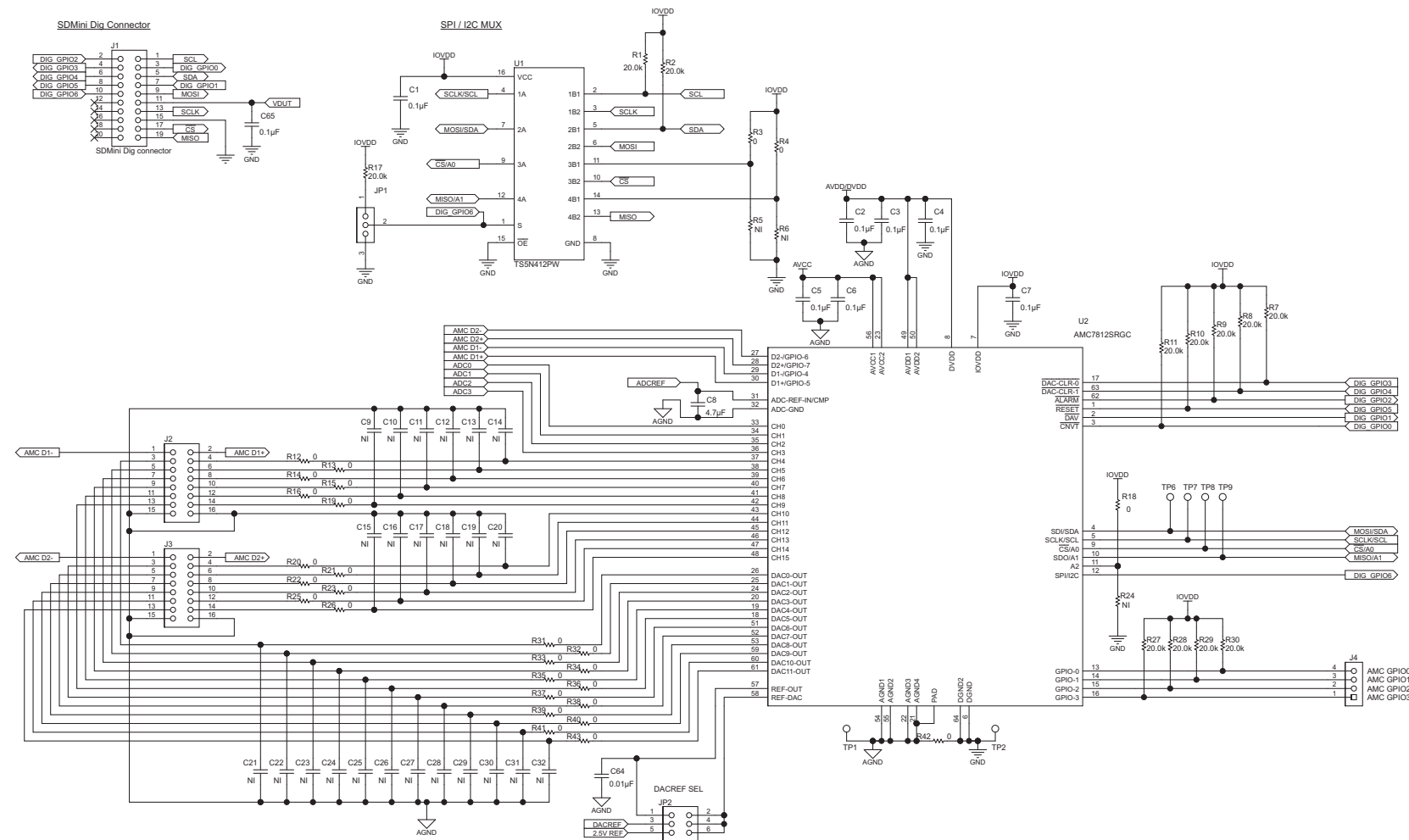

Figure 34. AMC7812EVM Schematic (1 of 3)

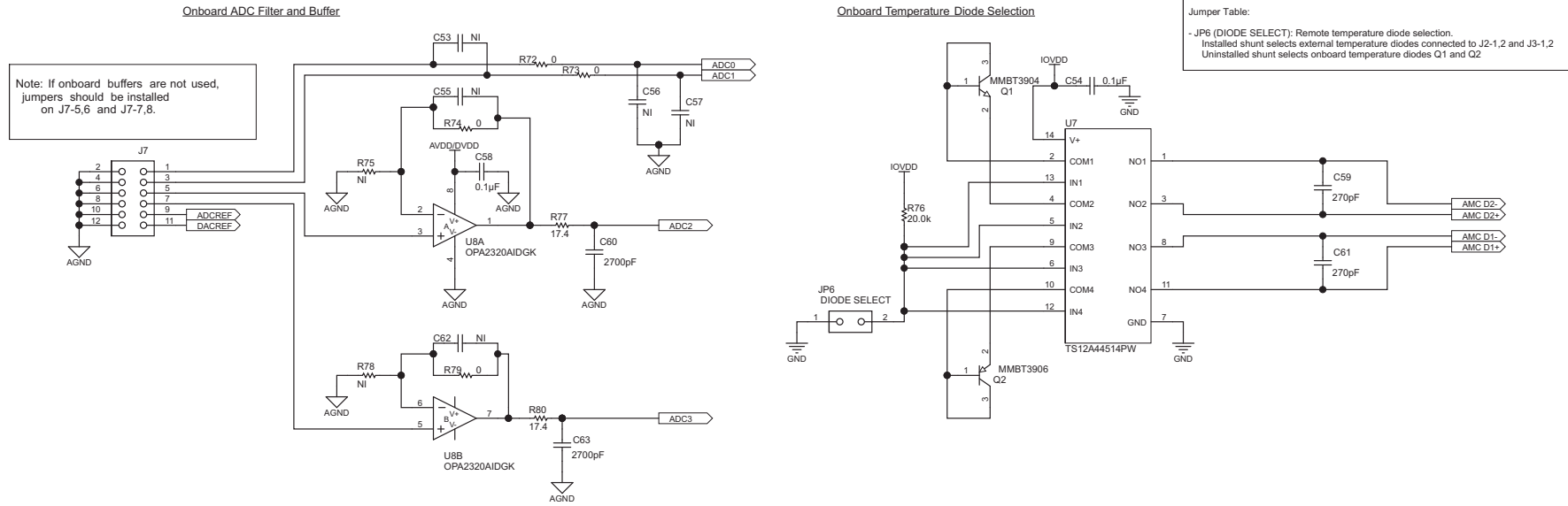

Figure 35. AMC7812EVM Schematic (2 of 3)

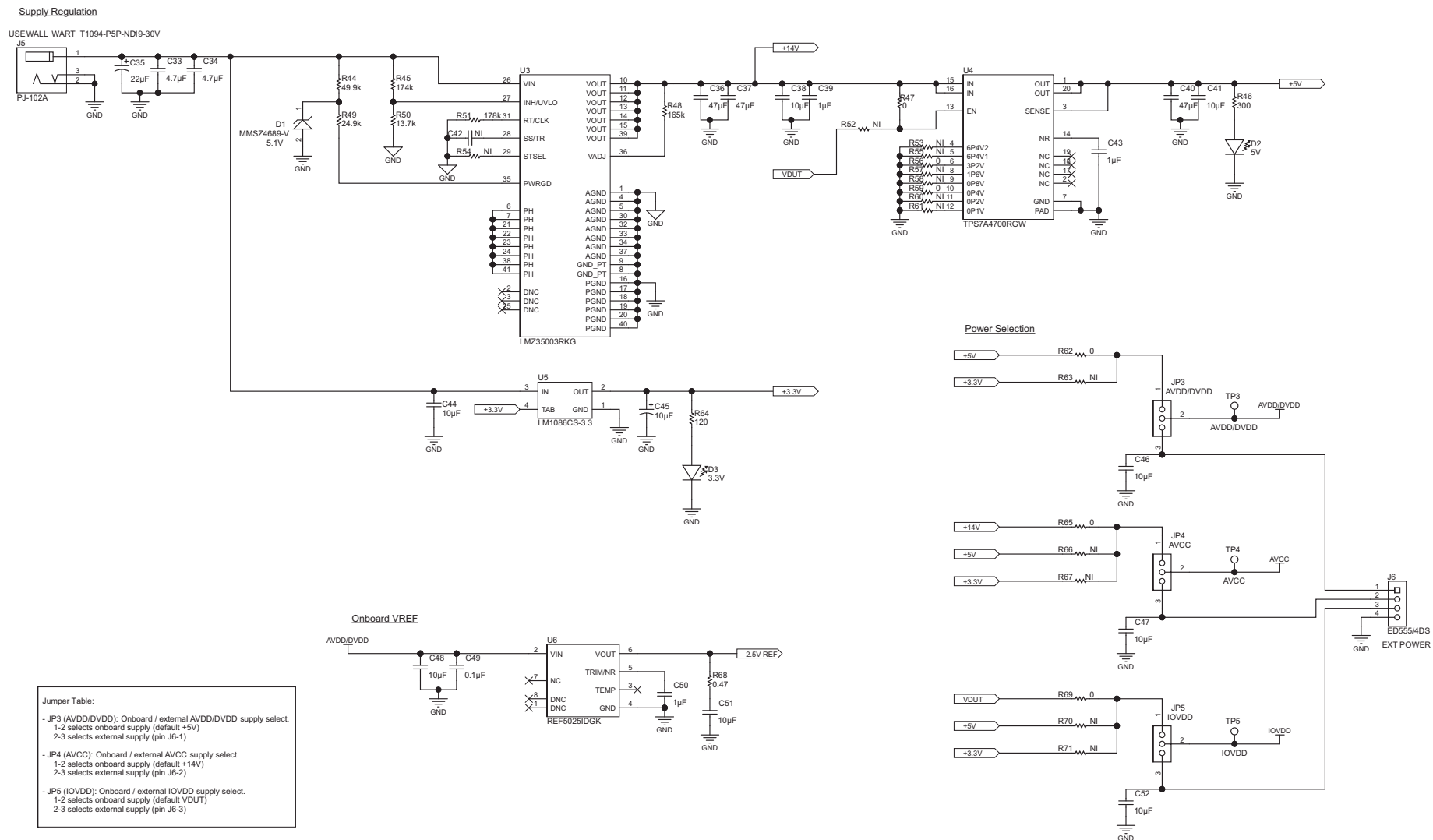

Figure 36. AMC7812EVM Schematic (3 of 3)

6.2 AMC7812EVM PCB Components Layout

Figure 37 shows the layout of the components for the AMC7812EVM board.

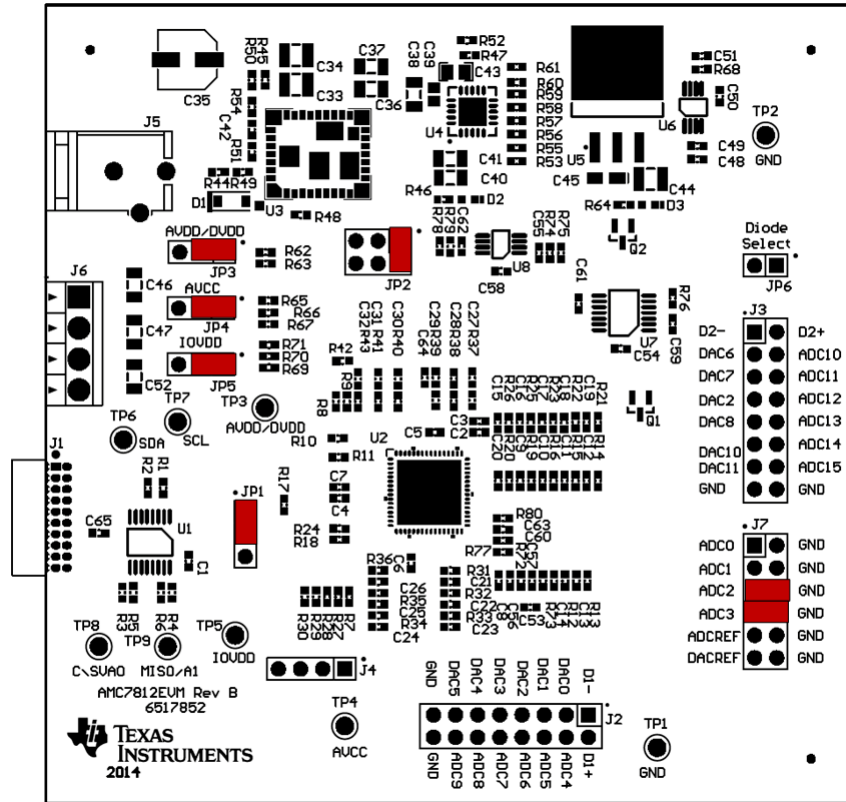

Figure 37. AMC7812EVM PCB Components Layout

6.3 AMC7812 Test Board Bill of Materials

Table 10 lists the BOM for this EVM.

Table 10. Bill of Materials

Item	Qty	Designator	Description	Manufacturer	Part Number
1	1		Printed Circuit Board	Any	6517852
2	11	C1, C2, C3, C4, C5, C6, C7, C49, C54, C58, C65	CAP, CERM, 0.1uF, 25V, +/-5%, X7R, 0603	AVX	06033C104JAT2A
3	1	C8	CAP, CERM, 4.7uF, 10V, +/-10%, X5R, 0603	TDK	CGB3B1X5R1A475K055AC
4	0	C9, C10, C11, C12, C13, C14, C15, C16, C17, C18, C19, C20, C21, C22, C23, C24, C25, C26, C27, C28, C29, C30, C31, C32, C42, C53, C55, C56, C57, C62	NI		
5	2	C33, C34	CAP, CERM, 4.7uF, 50V, +/-10%, X7R, 1210	MuRata	GRM32ER71H475KA88L
6	1	C35	CAP, AL, 22uF, 35V, +/-20%, 1 ohm, SMD	Panasonic	EEE-FC1V220P
7	3	C36, C37, C40	CAP, CERM, 47uF, 25V, +/-20%, X5R, 1206	TDK	C3216X5R1E476M160AC
8	5	C38, C41, C46, C47, C52	CAP, CERM, 10uF, 25V, +/-10%, X7R, 1206	MuRata	GRM31CR71E106KA12L
9	2	C39, C43	CAP, CERM, 1uF, 25V, +/-10%, X5R, 0805	TDK	C2012X5R1E105K
10	1	C44	CAP, CERM, 10uF, 50V, +/-10%, X7R, 1210	MuRata	GRM32ER71H106KA12L
11	1	C45	CAP, TA, 10uF, 10V, +/-10%, 0.9 ohm, SMD	AVX	TPSA106K010R0900
12	2	C48, C51	CAP, CERM, 10uF, 6.3V, +/-20%, X5R, 0603	TDK	C1608X5R0J106M
13	1	C50	CAP, CERM, 1uF, 16V, +/-10%, X5R, 0603	TDK	C1608X5R1C105K
14	2	C59, C61	CAP, CERM, 270pF, 50V, +/-5%, C0G/NP0, 0603	TDK	C1608C0G1H271J
15	2	C60, C63	CAP, CERM, 2700pF, 25V, +/-10%, X7R, 0603	MuRata	GRM188R71E272KA01D
16	1	C64	CAP, CERM, 0.01uF, 50V, +/-10%, X7R, 0603	TDK	C1608X7R1H103K
17	1	D1	Diode, Zener, 5.1V, 500mW, SOD-123	Vishay-Semiconductor	MMSZ4689-V
18	2	D2, D3	LED, Green, SMD	Lumex	SML-LX0603GW-TR
19	1	J1	Receptacle, 50mil 10x2, R/A, TH	Mill-Max	853-43-020-20-001000
20	2	J2, J3	Header, TH, 100mil, 2x8, Gold plated, 230 mil above insulator	Sullins Connector Solutions	PBC08DAAN
21	1	J4	Header, TH, 100mil, 4x1, Gold plated, 230 mil above insulator	Samtec	TSW-104-07-G-S
22	1	J5	Connector, DC Jack 2.1X5.5 mm, TH	CUI Inc.	PJ-102A
23	1	J6	Terminal Block, 6A, 3.5mm Pitch, 4-Pos, TH	On-Shore Technology	ED555/4DS
24	1	J7	Header, TH, 100mil, 6x2, Gold plated, 230 mil above insulator	Samtec	TSW-106-07-G-D
25	4	JP1, JP3, JP4, JP5	Header, TH, 100mil, 3x1, Gold plated, 230 mil above insulator	Samtec, Inc.	TSW-103-07-G-S
26	1	JP2	Header, TH, 100mil, 3x2, Gold plated, 230 mil above insulator	Samtec	TSW-103-07-G-D
27	1	JP6	Header, TH, 100mil, 2x1, Gold plated, 230 mil above insulator	Samtec	TSW-102-07-G-S
28	1	Q1	Transistor, NPN, 40V, 0.2A, SOT-23	Fairchild Semiconductor	MMBT3904
29	1	Q2	Transistor, PNP, 40V, 0.2A, SOT-23	Fairchild Semiconductor	MMBT3906
30	13	R1, R2, R7, R8, R9, R10, R11, R17, R27, R28, R29, R30, R76	RES, 20.0k ohm, 1%, 0.1W, 0603	Yageo America	RC0603FR-0720KL

Table 10. Bill of Materials (continued)

Item	Qty	Designator	Description	Manufacturer	Part Number
31	38	R3, R4, R12, R13, R14, R15, R16, R18, R19, R20, R21, R22, R23, R25, R26, R31, R32, R33, R34, R35, R36, R37, R38, R39, R40, R41, R42, R43, R47, R56, R59, R62, R65, R69, R72, R73, R74, R79	RES, 0 ohm, 5%, 0.1W, 0603	Yageo America	RC0603JR-070RL
32	0	R5, R6, R24, R52, R53, R54, R55, R57, R58, R60, R61, R63, R66, R67, R70, R71, R75, R78	NI		
33	1	R44	RES, 49.9k ohm, 1%, 0.1W, 0603	Yageo America	RC0603FR-0749K9L
34	1	R45	RES, 174k ohm, 1%, 0.1W, 0603	Yageo America	RC0603FR-07174KL
35	1	R46	RES, 300 ohm, 1%, 0.1W, 0603	Yageo America	RC0603FR-07300RL
36	1	R48	RES, 165k ohm, 1%, 0.1W, 0603	Yageo America	RC0603FR-07165KL
37	1	R49	RES, 24.9k ohm, 1%, 0.1W, 0603	Yageo America	RC0603FR-0724K9L
38	1	R50	RES, 13.7k ohm, 1%, 0.1W, 0603	Yageo America	RC0603FR-0713K7L
39	1	R51	RES, 178k ohm, 1%, 0.1W, 0603	Yageo America	RC0603FR-07178KL
40	1	R64	RES, 120 ohm, 1%, 0.1W, 0603	Yageo America	RC0603FR-07120RL
41	1	R68	RES, 0.47 ohm, 1%, 0.1W, 0603	Panasonic	ERJ-3RQFR47V
42	2	R77, R80	RES, 17.4 ohm, 1%, 0.1W, 0603	Yageo America	RC0603FR-0717R4L
43	2	TP1, TP2	Test Point, Miniature, Black, TH	Keystone	5001
44	7	TP3, TP4, TP5, TP6, TP7, TP8, TP9	Test Point, Miniature, Red, TH	Keystone	5000
45	1	U1	4-BIT 1-OF-2 FET MULTIPLEXER / DEMULTIPLEXER HIGH BANDWIDTH BUS SWITCH, PW0016A	Texas Instruments	TS5N412PW
46	1	U2	12-Bit ANALOG MONITORING AND CONTROL SOLUTION with Multichannel ADC, DACs, and Temperature Sensors, RGC0064A	Texas Instruments	AMC7812SRGC
47	1	U3	7-V to 50-V Input, 2.5-A Step-Down, Integrated Power Solution	Texas Instruments	LMZ35003RKG
48	1	U4	36-V, 1-A, 4.17-μVRMS, RF LDO Voltage Regulator, RGW0020A	Texas Instruments	TPS7A4700RGW
49	1	U5	1.5A Low Dropout Positive Regulators, 3-pin TO-263	National Semiconductor	LM1086CS-3.3/NOPB
50	1	U6	Low-Noise, Very Low Drift, Precision VOLTAGE REFERENCE, DGK0008A	Texas Instruments	REF5025IDGK
51	1	U7	LOW ON-STATE RESISTANCE QUAD SPST CMOS ANALOG SWITCHES, PW0014A	Texas Instruments	TS12A44514PW
52	1	U8	Precision, 20MHz, 0.9pA, Low-Noise, RRIO, CMOS Operational Amplifier with Shutdown, DGK0008A	Texas Instruments	OPA2320AIDGK
53	4		Bumpon, Hemisphere, 0.44 X 0.20, Clear	3M	SJ-5303 (CLEAR)
54	5		Shunt, 100mil, Gold plated, Black	3M	969102-0000-DA

Revision E History

NOTE: Page numbers for previous revisions may differ from page numbers in the current version.

Changes from D Revision (August 2014) to E Revision	Page
• Deleted row "+24-V wall supply" from Table 1 , and added Note 1.	3
• Changed text "An optional +24V wall supply..." in Section 2	4
• Changed Figure 1	4
• Changed "Default" and "Optional" blocks in Figure 2	4
• Added Note 1 to Table 4	9

Revision D History

Changes from C Revision (June 2014) to D Revision	Page
• Updated JP1 jumper function description in Default Jumper Settings table.....	9
• Removed jumper table	22

Revision C History

Changes from B Revision (June 2014) to C Revision	Page
• Changed title of document to AMC7812EVM-PDK User's Guide.....	1

Revision B History

Changes from A Revision (May 2013) to B Revision	Page
• Changed entire document: format and content. This user guide is now patterned after the AMC7832EVM user's guide. .	1

STANDARD TERMS AND CONDITIONS FOR EVALUATION MODULES

1. *Delivery:* TI delivers TI evaluation boards, kits, or modules, including any accompanying demonstration software, components, or documentation (collectively, an "EVM" or "EVMs") to the User ("User") in accordance with the terms and conditions set forth herein. Acceptance of the EVM is expressly subject to the following terms and conditions.
 - 1.1 EVMs are intended solely for product or software developers for use in a research and development setting to facilitate feasibility evaluation, experimentation, or scientific analysis of TI semiconductors products. EVMs have no direct function and are not finished products. EVMs shall not be directly or indirectly assembled as a part or subassembly in any finished product. For clarification, any software or software tools provided with the EVM ("Software") shall not be subject to the terms and conditions set forth herein but rather shall be subject to the applicable terms and conditions that accompany such Software
 - 1.2 EVMs are not intended for consumer or household use. EVMs may not be sold, sublicensed, leased, rented, loaned, assigned, or otherwise distributed for commercial purposes by Users, in whole or in part, or used in any finished product or production system.
2. *Limited Warranty and Related Remedies/Disclaimers:*
 - 2.1 These terms and conditions do not apply to Software. The warranty, if any, for Software is covered in the applicable Software License Agreement.
 - 2.2 TI warrants that the TI EVM will conform to TI's published specifications for ninety (90) days after the date TI delivers such EVM to User. Notwithstanding the foregoing, TI shall not be liable for any defects that are caused by neglect, misuse or mistreatment by an entity other than TI, including improper installation or testing, or for any EVMs that have been altered or modified in any way by an entity other than TI. Moreover, TI shall not be liable for any defects that result from User's design, specifications or instructions for such EVMs. Testing and other quality control techniques are used to the extent TI deems necessary or as mandated by government requirements. TI does not test all parameters of each EVM.
 - 2.3 If any EVM fails to conform to the warranty set forth above, TI's sole liability shall be at its option to repair or replace such EVM, or credit User's account for such EVM. TI's liability under this warranty shall be limited to EVMs that are returned during the warranty period to the address designated by TI and that are determined by TI not to conform to such warranty. If TI elects to repair or replace such EVM, TI shall have a reasonable time to repair such EVM or provide replacements. Repaired EVMs shall be warranted for the remainder of the original warranty period. Replaced EVMs shall be warranted for a new full ninety (90) day warranty period.
3. *Regulatory Notices:*
 - 3.1 *United States*
 - 3.1.1 *Notice applicable to EVMs not FCC-Approved:*

This kit is designed to allow product developers to evaluate electronic components, circuitry, or software associated with the kit to determine whether to incorporate such items in a finished product and software developers to write software applications for use with the end product. This kit is not a finished product and when assembled may not be resold or otherwise marketed unless all required FCC equipment authorizations are first obtained. Operation is subject to the condition that this product not cause harmful interference to licensed radio stations and that this product accept harmful interference. Unless the assembled kit is designed to operate under part 15, part 18 or part 95 of this chapter, the operator of the kit must operate under the authority of an FCC license holder or must secure an experimental authorization under part 5 of this chapter.
 - 3.1.2 *For EVMs annotated as FCC – FEDERAL COMMUNICATIONS COMMISSION Part 15 Compliant:*

CAUTION

This device complies with part 15 of the FCC Rules. Operation is subject to the following two conditions: (1) This device may not cause harmful interference, and (2) this device must accept any interference received, including interference that may cause undesired operation.

Changes or modifications not expressly approved by the party responsible for compliance could void the user's authority to operate the equipment.

FCC Interference Statement for Class A EVM devices

NOTE: This equipment has been tested and found to comply with the limits for a Class A digital device, pursuant to part 15 of the FCC Rules. These limits are designed to provide reasonable protection against harmful interference when the equipment is operated in a commercial environment. This equipment generates, uses, and can radiate radio frequency energy and, if not installed and used in accordance with the instruction manual, may cause harmful interference to radio communications. Operation of this equipment in a residential area is likely to cause harmful interference in which case the user will be required to correct the interference at his own expense.

FCC Interference Statement for Class B EVM devices

NOTE: This equipment has been tested and found to comply with the limits for a Class B digital device, pursuant to part 15 of the FCC Rules. These limits are designed to provide reasonable protection against harmful interference in a residential installation. This equipment generates, uses and can radiate radio frequency energy and, if not installed and used in accordance with the instructions, may cause harmful interference to radio communications. However, there is no guarantee that interference will not occur in a particular installation. If this equipment does cause harmful interference to radio or television reception, which can be determined by turning the equipment off and on, the user is encouraged to try to correct the interference by one or more of the following measures:

- Reorient or relocate the receiving antenna.
- Increase the separation between the equipment and receiver.
- Connect the equipment into an outlet on a circuit different from that to which the receiver is connected.
- Consult the dealer or an experienced radio/TV technician for help.

3.2 Canada

3.2.1 For EVMs issued with an Industry Canada Certificate of Conformance to RSS-210

Concerning EVMs Including Radio Transmitters:

This device complies with Industry Canada license-exempt RSS standard(s). Operation is subject to the following two conditions: (1) this device may not cause interference, and (2) this device must accept any interference, including interference that may cause undesired operation of the device.

Concernant les EVMs avec appareils radio:

Le présent appareil est conforme aux CNR d'Industrie Canada applicables aux appareils radio exempts de licence. L'exploitation est autorisée aux deux conditions suivantes: (1) l'appareil ne doit pas produire de brouillage, et (2) l'utilisateur de l'appareil doit accepter tout brouillage radioélectrique subi, même si le brouillage est susceptible d'en compromettre le fonctionnement.

Concerning EVMs Including Detachable Antennas:

Under Industry Canada regulations, this radio transmitter may only operate using an antenna of a type and maximum (or lesser) gain approved for the transmitter by Industry Canada. To reduce potential radio interference to other users, the antenna type and its gain should be so chosen that the equivalent isotropically radiated power (e.i.r.p.) is not more than that necessary for successful communication. This radio transmitter has been approved by Industry Canada to operate with the antenna types listed in the user guide with the maximum permissible gain and required antenna impedance for each antenna type indicated. Antenna types not included in this list, having a gain greater than the maximum gain indicated for that type, are strictly prohibited for use with this device.

Concernant les EVMs avec antennes détachables

Conformément à la réglementation d'Industrie Canada, le présent émetteur radio peut fonctionner avec une antenne d'un type et d'un gain maximal (ou inférieur) approuvé pour l'émetteur par Industrie Canada. Dans le but de réduire les risques de brouillage radioélectrique à l'intention des autres utilisateurs, il faut choisir le type d'antenne et son gain de sorte que la puissance isotrope rayonnée équivalente (p.i.r.e.) ne dépasse pas l'intensité nécessaire à l'établissement d'une communication satisfaisante. Le présent émetteur radio a été approuvé par Industrie Canada pour fonctionner avec les types d'antenne énumérés dans le manuel d'usage et ayant un gain admissible maximal et l'impédance requise pour chaque type d'antenne. Les types d'antenne non inclus dans cette liste, ou dont le gain est supérieur au gain maximal indiqué, sont strictement interdits pour l'exploitation de l'émetteur.

3.3 Japan

3.3.1 *Notice for EVMs delivered in Japan:* Please see http://www.tij.co.jp/lstds/ti_ja/general/eStore/notice_01.page 日本国内に輸入される評価用キット、ボードについては、次のところをご覧ください。
http://www.tij.co.jp/lstds/ti_ja/general/eStore/notice_01.page

3.3.2 *Notice for Users of EVMs Considered "Radio Frequency Products" in Japan:* EVMs entering Japan may not be certified by TI as conforming to Technical Regulations of Radio Law of Japan.

If User uses EVMs in Japan, not certified to Technical Regulations of Radio Law of Japan, User is required by Radio Law of Japan to follow the instructions below with respect to EVMs:

1. Use EVMs in a shielded room or any other test facility as defined in the notification #173 issued by Ministry of Internal Affairs and Communications on March 28, 2006, based on Sub-section 1.1 of Article 6 of the Ministry's Rule for Enforcement of Radio Law of Japan,
2. Use EVMs only after User obtains the license of Test Radio Station as provided in Radio Law of Japan with respect to EVMs, or
3. Use of EVMs only after User obtains the Technical Regulations Conformity Certification as provided in Radio Law of Japan with respect to EVMs. Also, do not transfer EVMs, unless User gives the same notice above to the transferee. Please note that if User does not follow the instructions above, User will be subject to penalties of Radio Law of Japan.

【無線電波を送信する製品の開発キットをお使いになる際の注意事項】 開発キットの中には技術基準適合証明を受けていないものがあります。技術適合証明を受けていないものご使用に際しては、電波法遵守のため、以下のいずれかの措置を取っていただく必要がありますのでご注意ください。

1. 電波法施行規則第6条第1項第1号に基づく平成18年3月28日総務省告示第173号で定められた電波暗室等の試験設備でご使用いただく。
2. 実験局の免許を取得後ご使用いただく。
3. 技術基準適合証明を取得後ご使用いただく。

なお、本製品は、上記の「ご使用にあたっての注意」を譲渡先、移転先に通知しない限り、譲渡、移転できないものとします。

上記を遵守頂けない場合は、電波法の罰則が適用される可能性があることをご留意ください。日本テキサス・インスツルメンツ株式会社

東京都新宿区西新宿 6 丁目 2 4 番 1 号

西新宿三井ビル

3.3.3 *Notice for EVMs for Power Line Communication:* Please see http://www.tij.co.jp/llds/ti_ja/general/eStore/notice_02.page

電力線搬送波通信についての開発キットをお使いになる際の注意事項については、次のところをご覧ください。http://www.tij.co.jp/llds/ti_ja/general/eStore/notice_02.page

4 *EVM Use Restrictions and Warnings:*

4.1 EVMS ARE NOT FOR USE IN FUNCTIONAL SAFETY AND/OR SAFETY CRITICAL EVALUATIONS, INCLUDING BUT NOT LIMITED TO EVALUATIONS OF LIFE SUPPORT APPLICATIONS.

4.2 User must read and apply the user guide and other available documentation provided by TI regarding the EVM prior to handling or using the EVM, including without limitation any warning or restriction notices. The notices contain important safety information related to, for example, temperatures and voltages.

4.3 *Safety-Related Warnings and Restrictions:*

4.3.1 User shall operate the EVM within TI's recommended specifications and environmental considerations stated in the user guide, other available documentation provided by TI, and any other applicable requirements and employ reasonable and customary safeguards. Exceeding the specified performance ratings and specifications (including but not limited to input and output voltage, current, power, and environmental ranges) for the EVM may cause personal injury or death, or property damage. If there are questions concerning performance ratings and specifications, User should contact a TI field representative prior to connecting interface electronics including input power and intended loads. Any loads applied outside of the specified output range may also result in unintended and/or inaccurate operation and/or possible permanent damage to the EVM and/or interface electronics. Please consult the EVM user guide prior to connecting any load to the EVM output. If there is uncertainty as to the load specification, please contact a TI field representative. During normal operation, even with the inputs and outputs kept within the specified allowable ranges, some circuit components may have elevated case temperatures. These components include but are not limited to linear regulators, switching transistors, pass transistors, current sense resistors, and heat sinks, which can be identified using the information in the associated documentation. When working with the EVM, please be aware that the EVM may become very warm.

4.3.2 EVMs are intended solely for use by technically qualified, professional electronics experts who are familiar with the dangers and application risks associated with handling electrical mechanical components, systems, and subsystems. User assumes all responsibility and liability for proper and safe handling and use of the EVM by User or its employees, affiliates, contractors or designees. User assumes all responsibility and liability to ensure that any interfaces (electronic and/or mechanical) between the EVM and any human body are designed with suitable isolation and means to safely limit accessible leakage currents to minimize the risk of electrical shock hazard. User assumes all responsibility and liability for any improper or unsafe handling or use of the EVM by User or its employees, affiliates, contractors or designees.

4.4 User assumes all responsibility and liability to determine whether the EVM is subject to any applicable international, federal, state, or local laws and regulations related to User's handling and use of the EVM and, if applicable, User assumes all responsibility and liability for compliance in all respects with such laws and regulations. User assumes all responsibility and liability for proper disposal and recycling of the EVM consistent with all applicable international, federal, state, and local requirements.

5. *Accuracy of Information:* To the extent TI provides information on the availability and function of EVMs, TI attempts to be as accurate as possible. However, TI does not warrant the accuracy of EVM descriptions, EVM availability or other information on its websites as accurate, complete, reliable, current, or error-free.

6. *Disclaimers:*
- 6.1 EXCEPT AS SET FORTH ABOVE, EVMS AND ANY WRITTEN DESIGN MATERIALS PROVIDED WITH THE EVM (AND THE DESIGN OF THE EVM ITSELF) ARE PROVIDED "AS IS" AND "WITH ALL FAULTS." TI DISCLAIMS ALL OTHER WARRANTIES, EXPRESS OR IMPLIED, REGARDING SUCH ITEMS, INCLUDING BUT NOT LIMITED TO ANY IMPLIED WARRANTIES OF MERCHANTABILITY OR FITNESS FOR A PARTICULAR PURPOSE OR NON-INFRINGEMENT OF ANY THIRD PARTY PATENTS, COPYRIGHTS, TRADE SECRETS OR OTHER INTELLECTUAL PROPERTY RIGHTS.
- 6.2 EXCEPT FOR THE LIMITED RIGHT TO USE THE EVM SET FORTH HEREIN, NOTHING IN THESE TERMS AND CONDITIONS SHALL BE CONSTRUED AS GRANTING OR CONFERRING ANY RIGHTS BY LICENSE, PATENT, OR ANY OTHER INDUSTRIAL OR INTELLECTUAL PROPERTY RIGHT OF TI, ITS SUPPLIERS/LICENSORS OR ANY OTHER THIRD PARTY, TO USE THE EVM IN ANY FINISHED END-USER OR READY-TO-USE FINAL PRODUCT, OR FOR ANY INVENTION, DISCOVERY OR IMPROVEMENT MADE, CONCEIVED OR ACQUIRED PRIOR TO OR AFTER DELIVERY OF THE EVM.
7. *USER'S INDEMNITY OBLIGATIONS AND REPRESENTATIONS.* USER WILL DEFEND, INDEMNIFY AND HOLD TI, ITS LICENSORS AND THEIR REPRESENTATIVES HARMLESS FROM AND AGAINST ANY AND ALL CLAIMS, DAMAGES, LOSSES, EXPENSES, COSTS AND LIABILITIES (COLLECTIVELY, "CLAIMS") ARISING OUT OF OR IN CONNECTION WITH ANY HANDLING OR USE OF THE EVM THAT IS NOT IN ACCORDANCE WITH THESE TERMS AND CONDITIONS. THIS OBLIGATION SHALL APPLY WHETHER CLAIMS ARISE UNDER STATUTE, REGULATION, OR THE LAW OF TORT, CONTRACT OR ANY OTHER LEGAL THEORY, AND EVEN IF THE EVM FAILS TO PERFORM AS DESCRIBED OR EXPECTED.
8. *Limitations on Damages and Liability:*
- 8.1 *General Limitations.* IN NO EVENT SHALL TI BE LIABLE FOR ANY SPECIAL, COLLATERAL, INDIRECT, PUNITIVE, INCIDENTAL, CONSEQUENTIAL, OR EXEMPLARY DAMAGES IN CONNECTION WITH OR ARISING OUT OF THESE TERMS AND CONDITIONS OR THE USE OF THE EVMS PROVIDED HEREUNDER, REGARDLESS OF WHETHER TI HAS BEEN ADVISED OF THE POSSIBILITY OF SUCH DAMAGES. EXCLUDED DAMAGES INCLUDE, BUT ARE NOT LIMITED TO, COST OF REMOVAL OR REINSTALLATION, ANCILLARY COSTS TO THE PROCUREMENT OF SUBSTITUTE GOODS OR SERVICES, RETESTING, OUTSIDE COMPUTER TIME, LABOR COSTS, LOSS OF GOODWILL, LOSS OF PROFITS, LOSS OF SAVINGS, LOSS OF USE, LOSS OF DATA, OR BUSINESS INTERRUPTION. NO CLAIM, SUIT OR ACTION SHALL BE BROUGHT AGAINST TI MORE THAN ONE YEAR AFTER THE RELATED CAUSE OF ACTION HAS OCCURRED.
- 8.2 *Specific Limitations.* IN NO EVENT SHALL TI'S AGGREGATE LIABILITY FROM ANY WARRANTY OR OTHER OBLIGATION ARISING OUT OF OR IN CONNECTION WITH THESE TERMS AND CONDITIONS, OR ANY USE OF ANY TI EVM PROVIDED HEREUNDER, EXCEED THE TOTAL AMOUNT PAID TO TI FOR THE PARTICULAR UNITS SOLD UNDER THESE TERMS AND CONDITIONS WITH RESPECT TO WHICH LOSSES OR DAMAGES ARE CLAIMED. THE EXISTENCE OF MORE THAN ONE CLAIM AGAINST THE PARTICULAR UNITS SOLD TO USER UNDER THESE TERMS AND CONDITIONS SHALL NOT ENLARGE OR EXTEND THIS LIMIT.
9. *Return Policy.* Except as otherwise provided, TI does not offer any refunds, returns, or exchanges. Furthermore, no return of EVM(s) will be accepted if the package has been opened and no return of the EVM(s) will be accepted if they are damaged or otherwise not in a resalable condition. If User feels it has been incorrectly charged for the EVM(s) it ordered or that delivery violates the applicable order, User should contact TI. All refunds will be made in full within thirty (30) working days from the return of the components(s), excluding any postage or packaging costs.
10. *Governing Law:* These terms and conditions shall be governed by and interpreted in accordance with the laws of the State of Texas, without reference to conflict-of-laws principles. User agrees that non-exclusive jurisdiction for any dispute arising out of or relating to these terms and conditions lies within courts located in the State of Texas and consents to venue in Dallas County, Texas. Notwithstanding the foregoing, any judgment may be enforced in any United States or foreign court, and TI may seek injunctive relief in any United States or foreign court.

Mailing Address: Texas Instruments, Post Office Box 655303, Dallas, Texas 75265
Copyright © 2015, Texas Instruments Incorporated

IMPORTANT NOTICE

Texas Instruments Incorporated and its subsidiaries (TI) reserve the right to make corrections, enhancements, improvements and other changes to its semiconductor products and services per JESD46, latest issue, and to discontinue any product or service per JESD48, latest issue. Buyers should obtain the latest relevant information before placing orders and should verify that such information is current and complete. All semiconductor products (also referred to herein as "components") are sold subject to TI's terms and conditions of sale supplied at the time of order acknowledgment.

TI warrants performance of its components to the specifications applicable at the time of sale, in accordance with the warranty in TI's terms and conditions of sale of semiconductor products. Testing and other quality control techniques are used to the extent TI deems necessary to support this warranty. Except where mandated by applicable law, testing of all parameters of each component is not necessarily performed.

TI assumes no liability for applications assistance or the design of Buyers' products. Buyers are responsible for their products and applications using TI components. To minimize the risks associated with Buyers' products and applications, Buyers should provide adequate design and operating safeguards.

TI does not warrant or represent that any license, either express or implied, is granted under any patent right, copyright, mask work right, or other intellectual property right relating to any combination, machine, or process in which TI components or services are used. Information published by TI regarding third-party products or services does not constitute a license to use such products or services or a warranty or endorsement thereof. Use of such information may require a license from a third party under the patents or other intellectual property of the third party, or a license from TI under the patents or other intellectual property of TI.

Reproduction of significant portions of TI information in TI data books or data sheets is permissible only if reproduction is without alteration and is accompanied by all associated warranties, conditions, limitations, and notices. TI is not responsible or liable for such altered documentation. Information of third parties may be subject to additional restrictions.

Resale of TI components or services with statements different from or beyond the parameters stated by TI for that component or service voids all express and any implied warranties for the associated TI component or service and is an unfair and deceptive business practice. TI is not responsible or liable for any such statements.

Buyer acknowledges and agrees that it is solely responsible for compliance with all legal, regulatory and safety-related requirements concerning its products, and any use of TI components in its applications, notwithstanding any applications-related information or support that may be provided by TI. Buyer represents and agrees that it has all the necessary expertise to create and implement safeguards which anticipate dangerous consequences of failures, monitor failures and their consequences, lessen the likelihood of failures that might cause harm and take appropriate remedial actions. Buyer will fully indemnify TI and its representatives against any damages arising out of the use of any TI components in safety-critical applications.

In some cases, TI components may be promoted specifically to facilitate safety-related applications. With such components, TI's goal is to help enable customers to design and create their own end-product solutions that meet applicable functional safety standards and requirements. Nonetheless, such components are subject to these terms.

No TI components are authorized for use in FDA Class III (or similar life-critical medical equipment) unless authorized officers of the parties have executed a special agreement specifically governing such use.

Only those TI components which TI has specifically designated as military grade or "enhanced plastic" are designed and intended for use in military/aerospace applications or environments. Buyer acknowledges and agrees that any military or aerospace use of TI components which have **not** been so designated is solely at the Buyer's risk, and that Buyer is solely responsible for compliance with all legal and regulatory requirements in connection with such use.

TI has specifically designated certain components as meeting ISO/TS16949 requirements, mainly for automotive use. In any case of use of non-designated products, TI will not be responsible for any failure to meet ISO/TS16949.

Products

Audio	www.ti.com/audio
Amplifiers	amplifier.ti.com
Data Converters	dataconverter.ti.com
DLP® Products	www.dlp.com
DSP	dsp.ti.com
Clocks and Timers	www.ti.com/clocks
Interface	interface.ti.com
Logic	logic.ti.com
Power Mgmt	power.ti.com
Microcontrollers	microcontroller.ti.com
RFID	www.ti-rfid.com
OMAP Applications Processors	www.ti.com/omap
Wireless Connectivity	www.ti.com/wirelessconnectivity

Applications

Automotive and Transportation	www.ti.com/automotive
Communications and Telecom	www.ti.com/communications
Computers and Peripherals	www.ti.com/computers
Consumer Electronics	www.ti.com/consumer-apps
Energy and Lighting	www.ti.com/energy
Industrial	www.ti.com/industrial
Medical	www.ti.com/medical
Security	www.ti.com/security
Space, Avionics and Defense	www.ti.com/space-avionics-defense
Video and Imaging	www.ti.com/video

TI E2E Community

e2e.ti.com