

DO NOT SCALE FROM THIS PRINT

DESIGNED & DIMENSIONED IN INCHES[MILLIMETERS]

PRF24-P-C-EE-047D-SD

SERIES -24: 2.4mm
 GENDER -P: PLUG
 TYPE -C: CABLE
 FINISH -EE: 50μ" EXTRA HEAVY GOLD CENTER CONTACT, 50μ" EXTRA HEAVY GOLD OUTER CONTACT
 TERMINATION -D: DIRECT SOLDER
 ORIENTATION -S: STRAIGHT
 CABLE TYPE -047D: .047 SEMI-RIGID

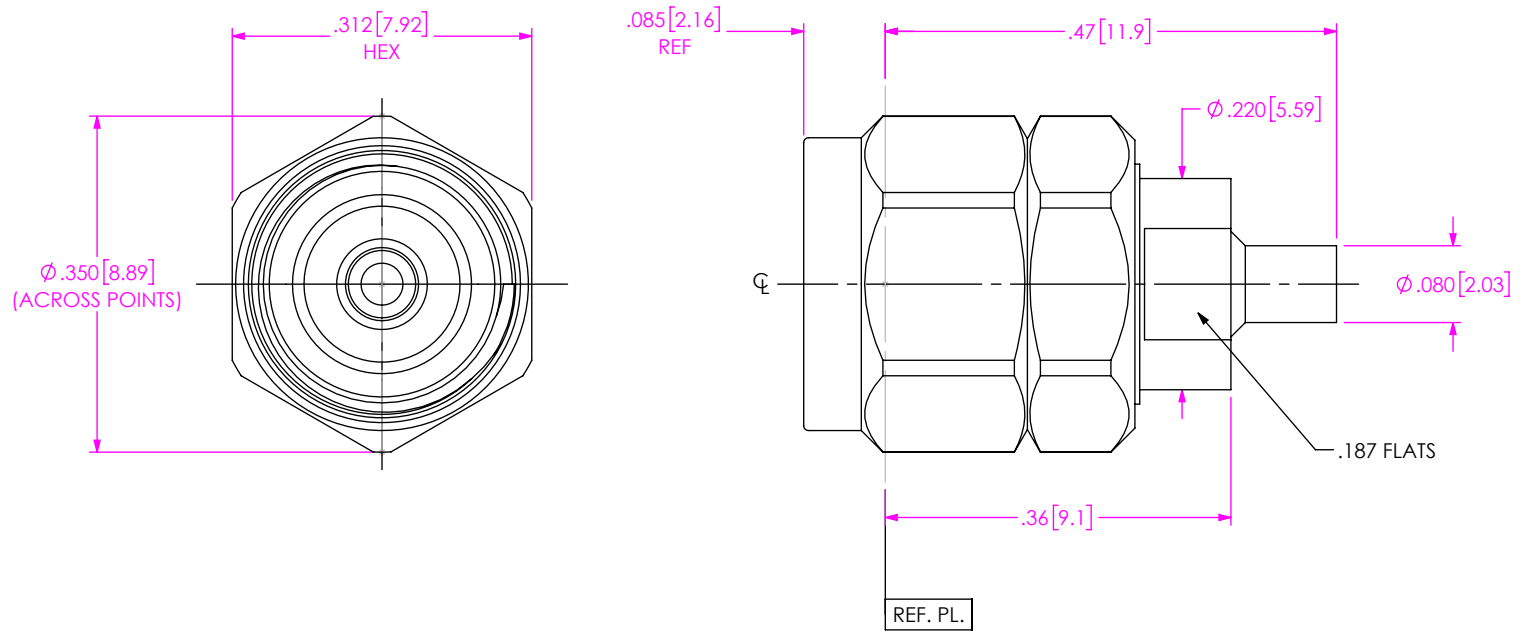

NOTES:

- MATERIAL:
 COUPLING NUT & BUSHING: STAINLESS STEEL.
 BODY & CONTACT, LOCK RING: BERYLLIUM COPPER.
 DIELECTRIC BEAD: ULTEM 1000.
 SUPPORT BEAD: PTFE.
 GASKET: SILICONE RUBBER.
- FINISH:
 COUPLING NUT & BUSHING: PASSIVATED.
 BODY & CONTACT: GOLD OVER NICKEL PLATE,
 50 MIN GOLD OVER 50 MIN NICKEL.
- PCI P/N: 4117.

c:\enterprisevault\DWG\MISC\MKTG\PRF24-P-C-EE-047D-SD-MKT.SLDDRW

UNLESS OTHERWISE SPECIFIED, DIMENSIONS ARE IN INCHES. TOLERANCES ARE: DECIMALS ANGLES .XX: ±.02[0.5] 1° .XXX: ±.005[0.13] .XXXX: ±.0005[0.013]	PROPRIETARY NOTE THIS DOCUMENT CONTAINS CONFIDENTIAL AND PROPRIETARY INFORMATION AND ALL DESIGN, MANUFACTURING, REPRODUCTION, USE, PATENT RIGHTS AND SALES RIGHTS ARE EXPRESSLY RESERVED BY SAMTEC, INC. THIS DOCUMENT SHALL NOT BE DISCLOSED, IN WHOLE OR PART, TO ANY UNAUTHORIZED PERSON OR ENTITY NOR REPRODUCED, TRANSFERRED OR INCORPORATED IN ANY OTHER PROJECT IN ANY MANNER WITHOUT THE EXPRESS WRITTEN CONSENT OF SAMTEC, INC.	 520 PARK EAST BLVD., NEW ALBANY, IN 47150 PHONE: 812-944-6733 FAX: 812-948-5047 e-Mail: info@SAMTEC.com code 55322 DESCRIPTION: 2.4MM PLUG, DIRECT SOLDER FOR .047 SEMI-RIGID CABLE DWG. NO. PRF24-P-C-EE-047D-SD BY: ETHAN C 03/03/2021 SHEET 1 OF 2
DO NOT SCALE DRAWING SHEET SCALE: 4:1		

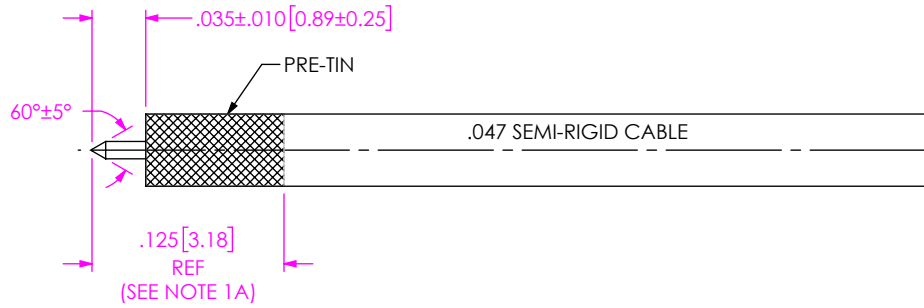

- 1A. PRE-TIN CABLE OUTER JACKET OVER APPROX. LENGTH SHOWN.
- 1B. TRIM CABLE TO EXPOSE CENTER CONDUCTOR AS SHOWN.
- 1C. POINT CENTER CONDUCTOR AS INDICATED.

IN-PROCESS 1

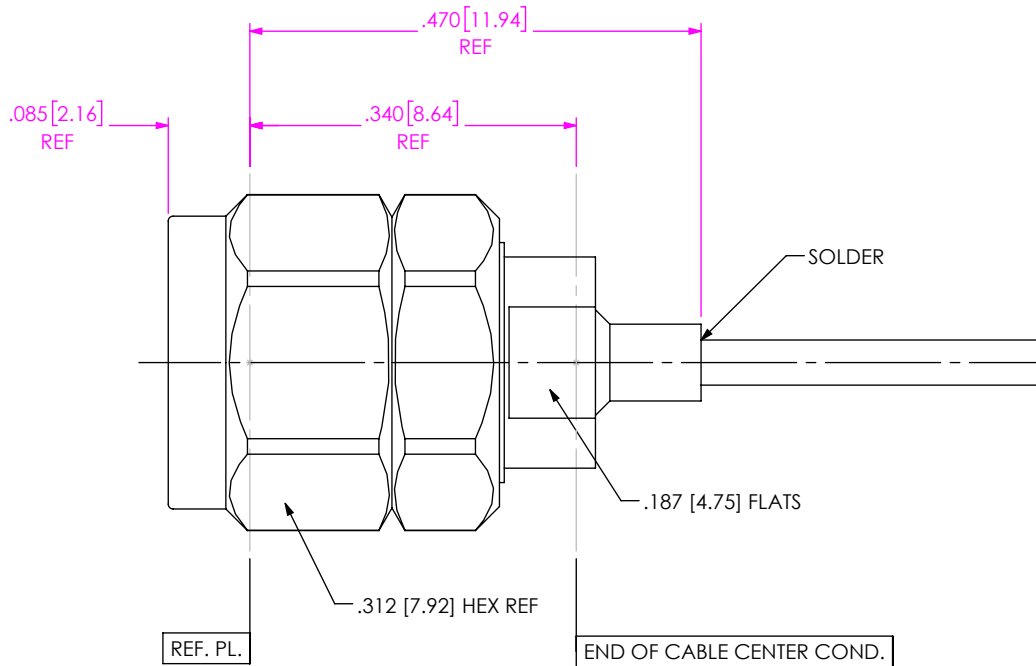

- 2A. INSERT CABLE INTO CONNECTOR UNTIL CENTER CONDUCTOR PLUGS IN AND CABLE SEATS IN CONNECTOR BORE.
- 2B. SOLDER CABLE JACKET TO BODY WHERE SHOWN APPLYING HEAT TO EXTENDED BODY TAIL.

IN-PROCESS 2

<p>DO NOT SCALE DRAWING</p> <p>SHEET SCALE: 4:1</p>	<p>PROPRIETARY NOTE</p> <p>THIS DOCUMENT CONTAINS CONFIDENTIAL AND PROPRIETARY INFORMATION AND ALL DESIGN, MANUFACTURING, REPRODUCTION, USE, PATENT RIGHTS AND SALES RIGHTS ARE EXPRESSLY RESERVED BY SAMTEC, INC. THIS DOCUMENT SHALL NOT BE DISCLOSED, IN WHOLE OR PART, TO ANY UNAUTHORIZED PERSON OR ENTITY NOR REPRODUCED, TRANSFERRED OR INCORPORATED IN ANY OTHER PROJECT IN ANY MANNER WITHOUT THE EXPRESS WRITTEN CONSENT OF SAMTEC, INC.</p>	<p>samtec</p> <p>520 PARK EAST BLVD, NEW ALBANY, IN 47150 PHONE: 812-944-6733 FAX: 812-948-5047 e-Mail info@SAMTEC.com code 55322</p>
	<p>DESCRIPTION: 2.4MM PLUG, DIRECT SOLDER FOR .047 SEMI-RIGID CABLE</p>	
	<p>DWG. NO. PRF24-P-C-EE-047D-SD</p>	
<p>BY: ETHAN C 03/03/2021</p>		<p>SHEET 2 OF 2</p>