

SF2237C

515.0 MHz
SAW Filter

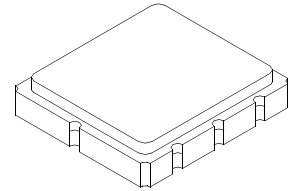

SM5050-8

- High Performance SAW Filter
- 5 x 5 mm Surface-mount Package
- Complies with Directive 2011/65/EU (RoHS)
- Moisture Sensitivity Level: 1
- AEC-Q200 Qualified

Absolute Maximum Ratings

Rating	Value	Units
Maximum Incident Power in Passband	+10	dBm
Maximum DC Voltage Between any Two Active Terminals	3	VDC
Operable Temperature Range	-45 to +125	°C
Specification Temperature Range	-40 to +85	°C
Storage Temperature Range in Tape and Reel	-40 to +85	°C
Suitable for Lead-free Soldering - Maximum Soldering Profile	260 °C for 30 s	

Electrical Characteristics

Characteristic	Sym	Notes	Min	Typ	Max	Units
Nominal Center Frequency	f_c			515.0		MHz
Insertion Loss @ 510 - 520 MHz				2.7	3.0	dB
1 dB Bandwidth	BW_1		18	34		MHz
Amplitude Ripple, $f_c \pm 11.5$ MHz				0.6	1.5	dB _{P-P}
Rejection referenced to IL at Peak:						
400 to 430 MHz			35	50		dB
430 to 470 MHz			32	40		
550 to 600 MHz			20	30		
600 to 740 MHz			35	40		
Frequency Temperature Drift				-93		ppm/°C

Case Style	5 x 5 mm Nominal Footprint					
Lid Symbolization, Y=year, WW=week, S=shift, Dot=pin 1 indicator	971, <u>YWWS</u>					
Standard Reel Quantity	Reel Size 7 Inch	500 Pieces/Reel				
	Reel Size 13 Inch	3000 Pieces/Reel				

Electrical Connections

Connection	Terminals
Input	1
Output	5
Case Ground	All others

 **CAUTION: Electrostatic Sensitive Device. Observe precautions for handling.**

NOTES:

1. The design, manufacturing process, and specifications of this device are subject to change.
2. US or International patents may apply.
3. RoHS compliant from the first date of manufacture.

Filter Amplitude and Group Delay Response Plots

S21 Response: (span 350 MHz)

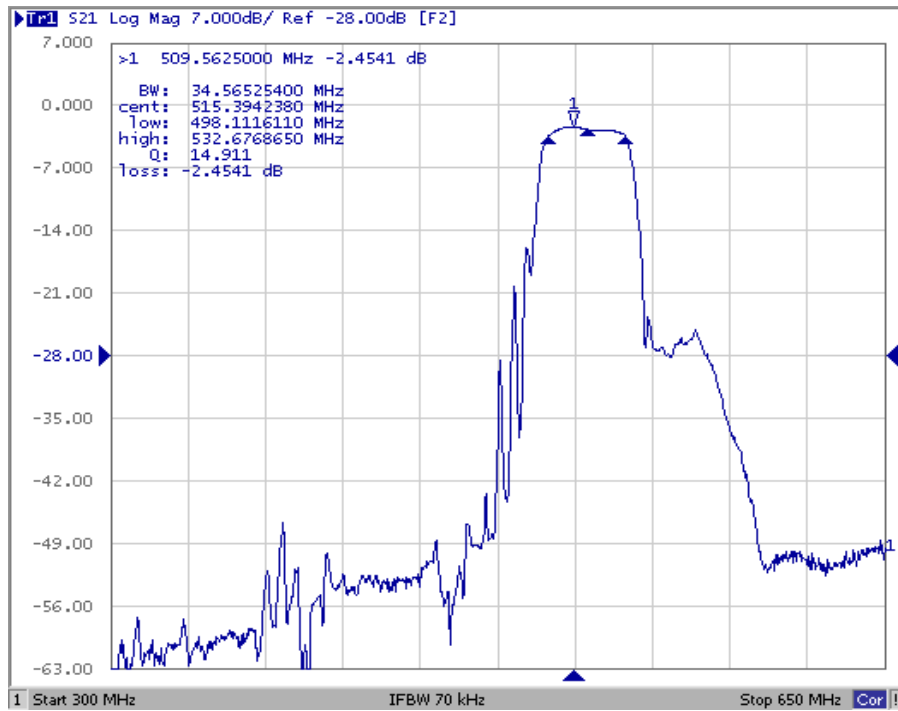

Group Delay Response: (span 50 MHz)

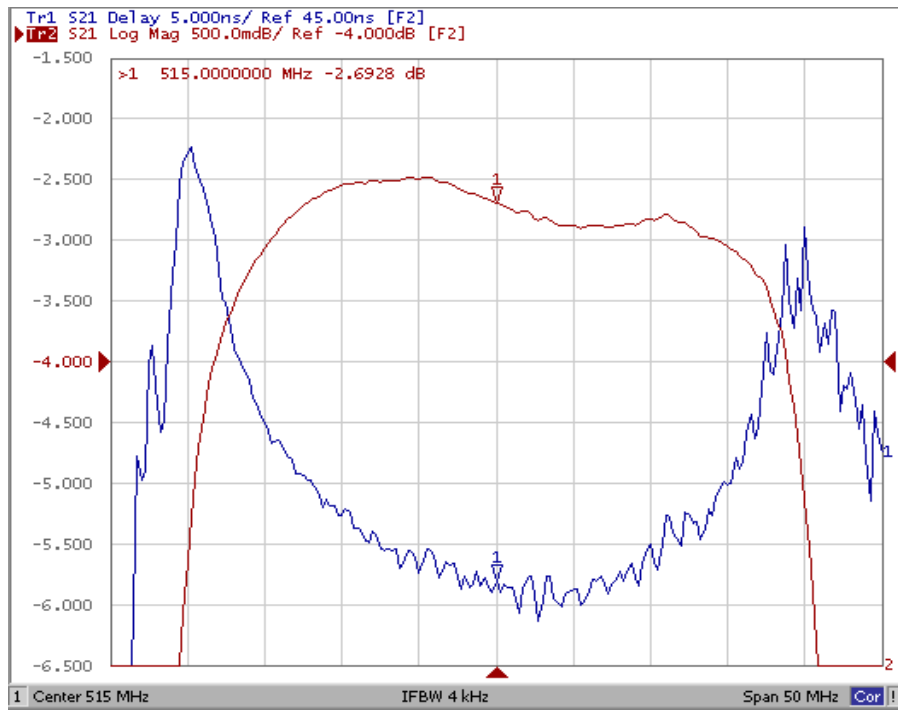

S11 Smith Chart: (span 350 MHz)

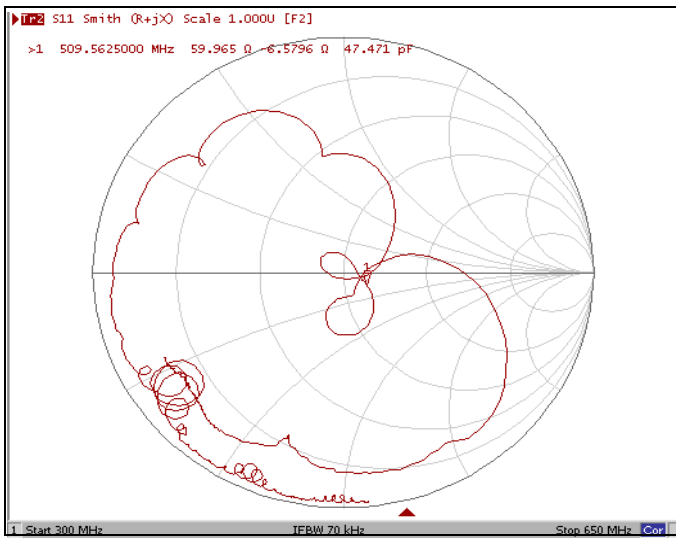

S22 Smith Chart: (span 350 MHz)

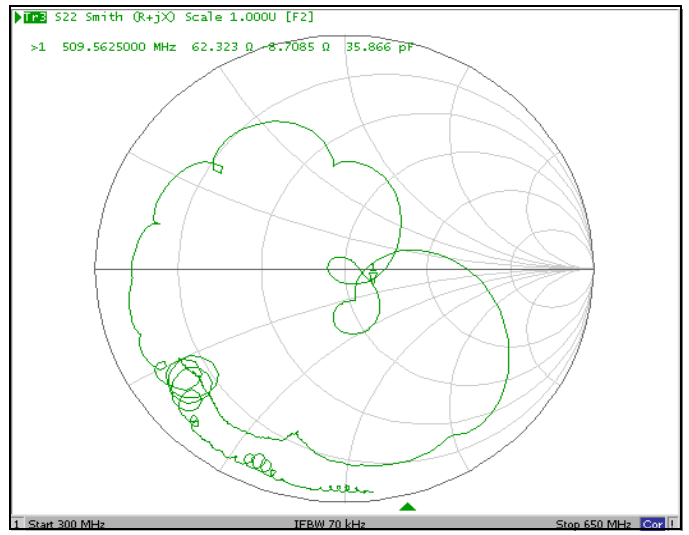

Test Circuit

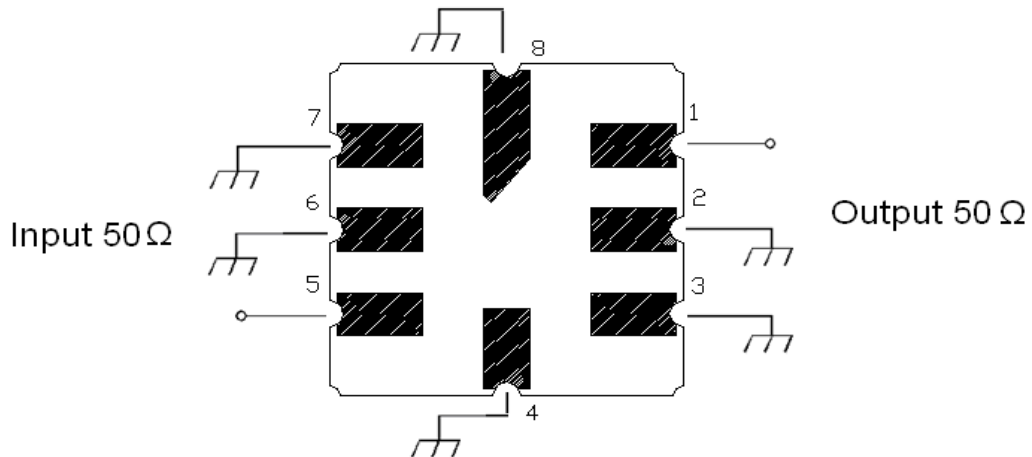

SM5050-8 Case

8-Terminal Ceramic Surface-Mount Case 5.0 X 5.0 mm Nominal Footprint

Case Dimensions

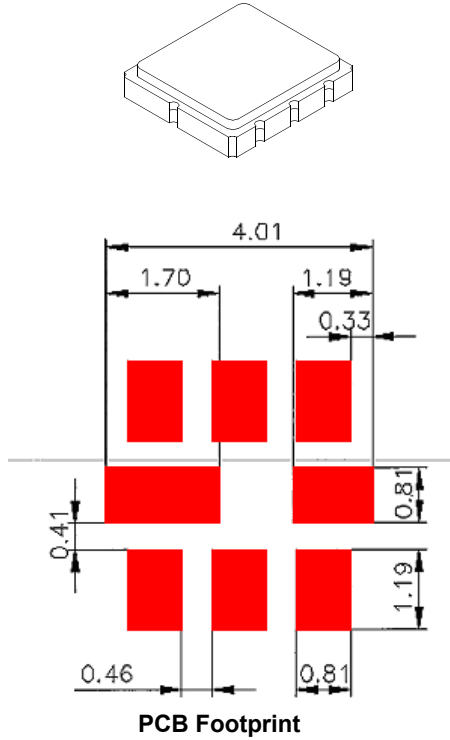

Dimension	mm			Inches		
	Min	Nom	Max	Min	Nom	Max
A	4.80	5.00	5.20	0.189	0.197	0.205
B	4.80	5.00	5.20	0.189	0.197	0.205
C	1.30	1.50	1.70	0.050	0.060	0.067
D	1.98	2.08	2.18	0.078	0.082	0.086
E	1.07	1.17	1.27	0.042	0.046	0.050
F	0.50	0.64	0.70	0.020	0.025	0.028
G	2.39	2.54	2.69	0.094	0.100	0.106
H		1.35			0.053	

Case Materials

Materials	
Solder Pad Plating	0.3 to 1.0 μm Gold over 1.27 to 8.89 μm Nickel
Lid Plating	2.0 to 3.0 μm Nickel
Body	Al_2O_3 Ceramic

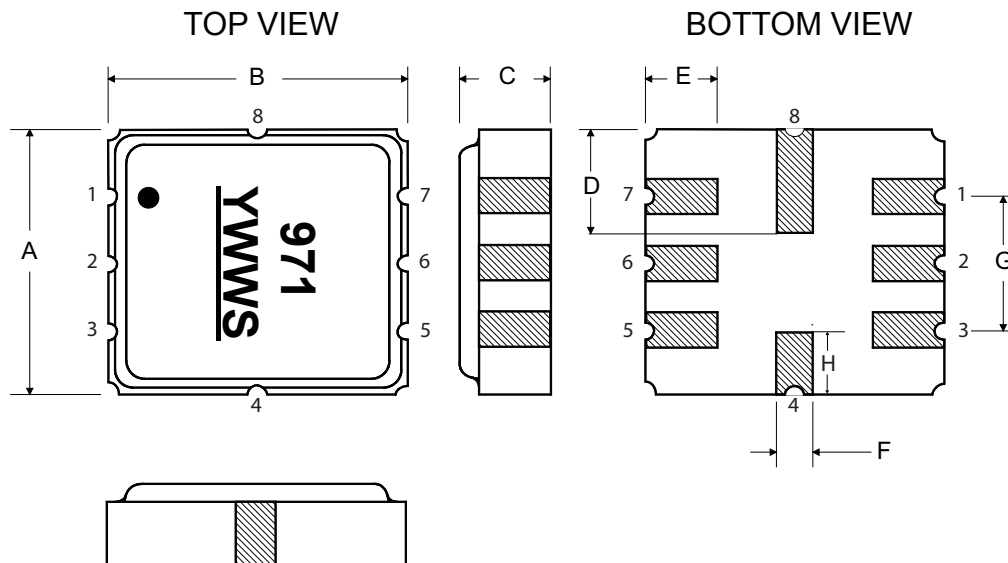

Tape and Reel Specifications

Tape and Reel Standard per ANSI/EIA-481

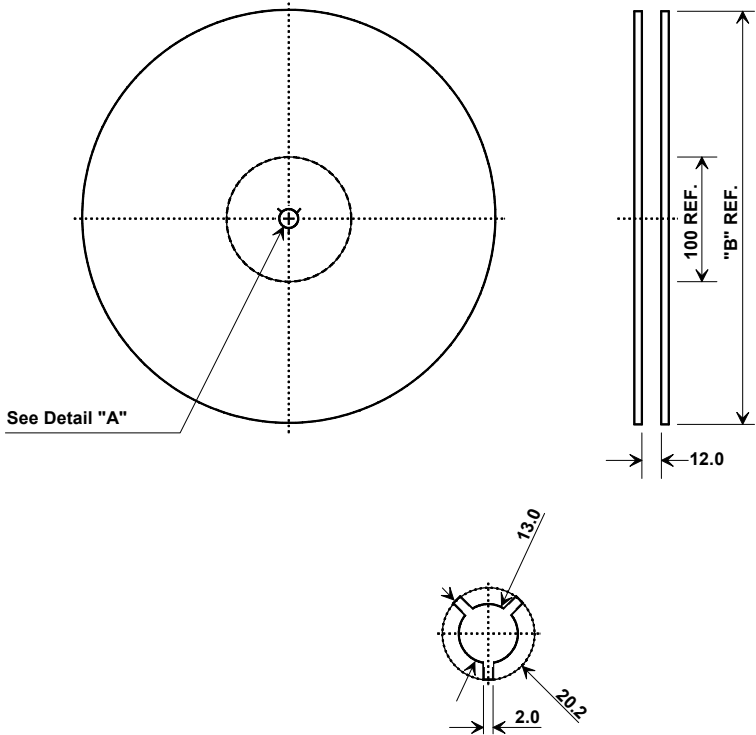

"B" Nominal Size		Quantity Per Reel
Inches	millimeters	
7	178	500
13	330	3000

COMPONENT ORIENTATION and DIMENSIONS

Carrier Tape Dimensions	
Ao	5.3 mm
Bo	5.3 mm
Ko	2.0 mm
Pitch	8.0 mm
W	12.0 mm

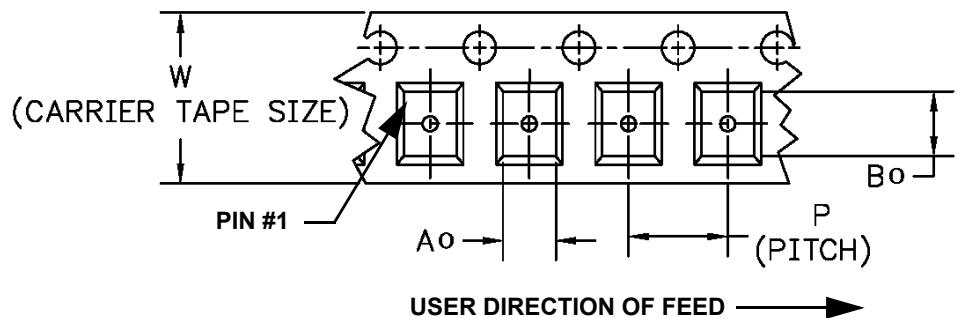
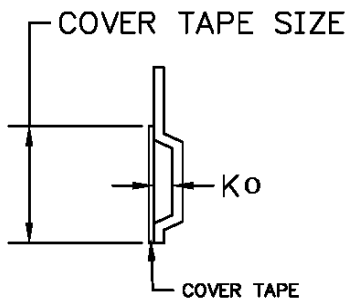

Recommended Reflow Profile

1. Preheating shall be fixed at 150~180°C for 60~90 seconds.
2. Ascending time to preheating temperature 150°C shall be 30 seconds min.
3. Heating shall be fixed at 220°C for 50~80 seconds and at 260°C +0/-5°C peak (10 seconds).
4. Time: 5 times maximum.

