

Description

The SSC Communication Board (SSC-CB) is part of the modular SSC Evaluation Kits. These kits provide hardware and software for a very simple and intuitive method of evaluating IDT's sensor signal conditioner (SSC) families of ICs, including ZSC31xxx, ZSSC30xx*, ZSSC31xx, ZSSC41xx, and ZSSC5101. For the evaluation of different SSC ICs, only the IC-specific SSC Evaluation Board and software are needed; other parts of the kit hardware (the SSC Communication Board and if applicable, the SSC Sensor Replacement Board) are typically the same and interchangeable between different kits. The SSC-CB can also be used for communication with the user's SSC application module.

The SSC Communication Board V4.1† can provide the power supply for the evaluation hardware and handle the communication with the user's computer via a USB interface. To prevent malfunctioning or damage, a galvanic isolation to the computer's USB port is established on-board via digital isolators for the information lines and an isolated DC/DC converter for the power line. It is also possible to supply the SSC-CB and connected kit boards or user modules by an external power line (12V typical) via the KL1 screw terminal on the SSC-CB. It is also possible to supply low-voltage devices with a fixed 1.8 or 3.3 VDC internal voltage. Alternatively the connected application could be supplied via the KL2 screw terminal with a voltage of 1.0 to 3.6 VDC.

A USB-UART device on the SSC-CB transfers all signals to the standardized USB port of the user's computer. Its UART interface is connected via digital isolators with the UART of an on-board microcontroller that controls all functions of the Evaluation Kit and of the SSC IC to be evaluated. Its software allows direct communication with the SSC IC via several interface options depending on the IC: I2C, SPI, ZACwire™ (One-Wire Interface (OWI)), LIN via a discrete level shifter, or SENT. The microcontroller also controls the power lines (5VDC and two lines for 12VDC) by driving several electronic switches. The microcontroller displays the status of communication via LEDs.

An on-board dual header strip enables access to all signal and power lines. This allows a simple signal check; e.g., by a digital oscilloscope, a multimeter, or a connection with user-specific hardware.

Important: Always ensure that there is no power when connecting SSC Evaluation Kit boards.

Features

- Interface fully compatible with USB 2.0
- “Plug & play” capability
- Power for the SSC Evaluation Kit provided by the USB port or an external power supply as selected with a jumper setting
- Internal generation of all required voltage levels: 5VDC and 12VDC
- On-board galvanic isolation between the user's computer and the Evaluation Kit hardware
- Access to all digital communication lines of the IDT SSC IC being evaluated
- Support for the ZSC31xxx, ZSSC30xx, ZSSC31xx, ZSSC41xx, and ZSSC5101 SSC Evaluation Kits and the SSC Mass Calibration System
- Computer-controlled configuration and calibration via USB interface – simple, low cost
- USB port driver included in the Evaluation Kit setup software – simple installation

SSC Communication Board V4.1

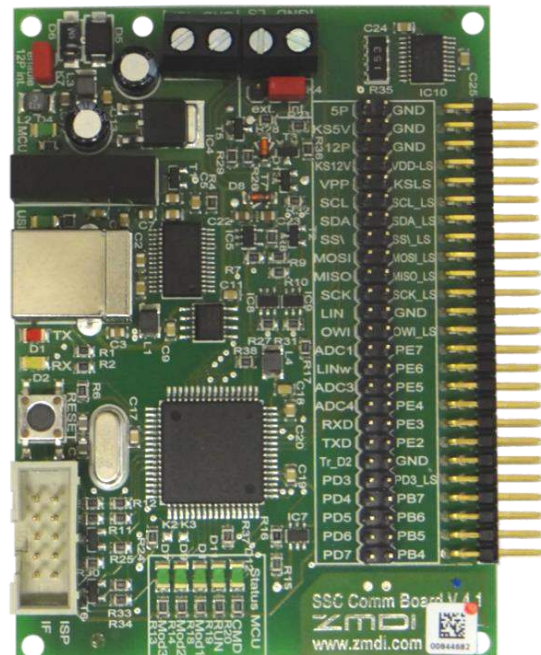

* The SSC-CB does not support the ZSSC30x6, ZSSC3218, or ZSSC3224 kits, which use different communications boards.

† This document applies only to V4.1 of the SSC-CB.

Important Notes

Disclaimer

Integrated Device Technology, Inc. and its affiliated companies (herein referred to as "IDT") shall not be liable for any damages arising out of defects resulting from

- (i) delivered hardware or software
- (ii) non-observance of instructions contained in this manual and in any other documentation provided to user, or
- (iii) misuse, abuse, use under abnormal conditions, or alteration by anyone other than IDT.

TO THE EXTENT PERMITTED BY LAW, IDT HEREBY EXPRESSLY DISCLAIMS AND USER EXPRESSLY WAIVES ANY AND ALL WARRANTIES, WHETHER EXPRESS, IMPLIED, OR STATUTORY, INCLUDING, WITHOUT LIMITATION, IMPLIED WARRANTIES OF MERCHANTABILITY AND OF FITNESS FOR A PARTICULAR PURPOSE, STATUTORY WARRANTY OF NON-INFRINGEMENT, AND ANY OTHER WARRANTY THAT MAY ARISE BY REASON OF USAGE OF TRADE, CUSTOM, OR COURSE OF DEALING.

Restrictions in Use

The software and the hardware for the ZSC31xxx / ZSSC3xxx / ZSSC41xx / ZSSC5101 SSC Evaluation Kits are designed for IC evaluation, laboratory setup, and module development only.

IDT's SSC Evaluation Kit hardware and software must not be used for module production or production test setups.

Contents

1. Electrical Specifications.....	4
2. SSC Communication Board Connections.....	5
3. Software Installation	6
3.1 System Requirements	6
3.2 USB Driver Installation	6
4. Circuit Description	6
4.1 USB Power and the Communication Interface	6
5. Special Functions of the SSC Communication Board	7
5.1 Trigger	7
5.2 Pull-up Resistor for Support of Data Communication	7
5.3 ADC Channel ADC0 to ADC4	7
5.4 Digital Channels PB4 to PB7, PD2 to PD7, and PE2 to PE7	7
5.5 RXD/TXD Interface.....	7
5.6 LIN Channel.....	7
5.7 I2C Channel.....	8
5.8 SPI Channel	8
5.9 OWI Channel (ZACwire™)	8
5.10 VPP Pulse Generation.....	8
5.11 5V Channel.....	8
5.12 12V Channel.....	8
5.13 Level-Shifter Channel	8

6.	SSC Evaluation Kit Controller Language.....	9
6.1	SSC Evaluation Kit Controller Language Commands	9
7.	SSC Communication Board V4.1 – Schematics.....	11
8.	Glossary	14
9.	Ordering Information.....	15
10.	Revision History.....	15

List of Figures

Figure 1.	Overview SSC Communication Board.....	5
Figure 2.	Example Start Sequence with Trigger Configuration.....	10
Figure 3.	SSC Communication Board V4.1 Schematic Part 1: USB-Interface Circuit	11
Figure 4.	SSC Communication Board Schematic V4.1 Schematic Part 2: MCU Circuit.....	12
Figure 5.	SSC Communication Board Schematic V4.1 Part 3: Level Shifter and 50-pin Connector.....	13

List of Tables

Table 1.	Command Example.....	9
----------	----------------------	---

1. Electrical Specifications

Parameter	Symbol	Conditions	Min	Typ	Max	Units
Ambient temperature range ^[a]	T _{AMB}		+10		+45	°C
External voltage supply input on KL1	V _{EXT_KL1}		8	12	16	V DC
External voltage supply input on KL2	V _{EXT_KL2}		1.0		3.6	V DC
USB current	I _{USB}		40		500	mA
Current capability of 12v supply via DC/DC ^[b]	I _{12V_DC/DC}				167	mA
Power dissipation	P _{MAX}				1500	mW
Current at 12P pin on K5/K6	I _{12P}	With internal supply ^[c]			40	mA
		With external voltage supply via KL1			150	mA
Current at KS12V pin on K5/K6	I _{KS12V}	With internal supply ^[c]			40	mA
		With external voltage supply via KL1			50	mA
Current at VPP pin on K5/K6	I _{VPP}	With internal supply ^[c]			40	mA
		With external voltage supply via KL1			50	mA
Current at 5P pin on K5/K6	I _{5P}	With internal supply ^[c]			40	mA
		With external voltage supply via KL1			150	mA
Current at KS5V pin on K5/K6	I _{KS5V}	With internal supply ^[c]			100	mA
		With external voltage supply via KL1			500	mA
Current at VDD-LS pin on K5/K6	I _{VDD-LS}	With internal supply ^[c]			50	mA
		With external voltage supply via KL1			150	mA
Current at KSLS pin on K5/K6	I _{KSLS}	With internal supply ^[c]			50	mA
		With external voltage supply via KL1			150	mA

[a] Important: The SSC Communication Board is designed for operation at room temperature only. Do not place this board in temperature chambers during calibration.

[b] Total, including SSC Communication Board power supply.

[c] Complete power supply via USB. Total amount / sum of current must not exceed specified power dissipation of DC/DC converter.

2. SSC Communication Board Connections

Figure 1. Overview SSC Communication Board

Note: The in-circuit serial programming (ISP) connector is reserved for IDT use.

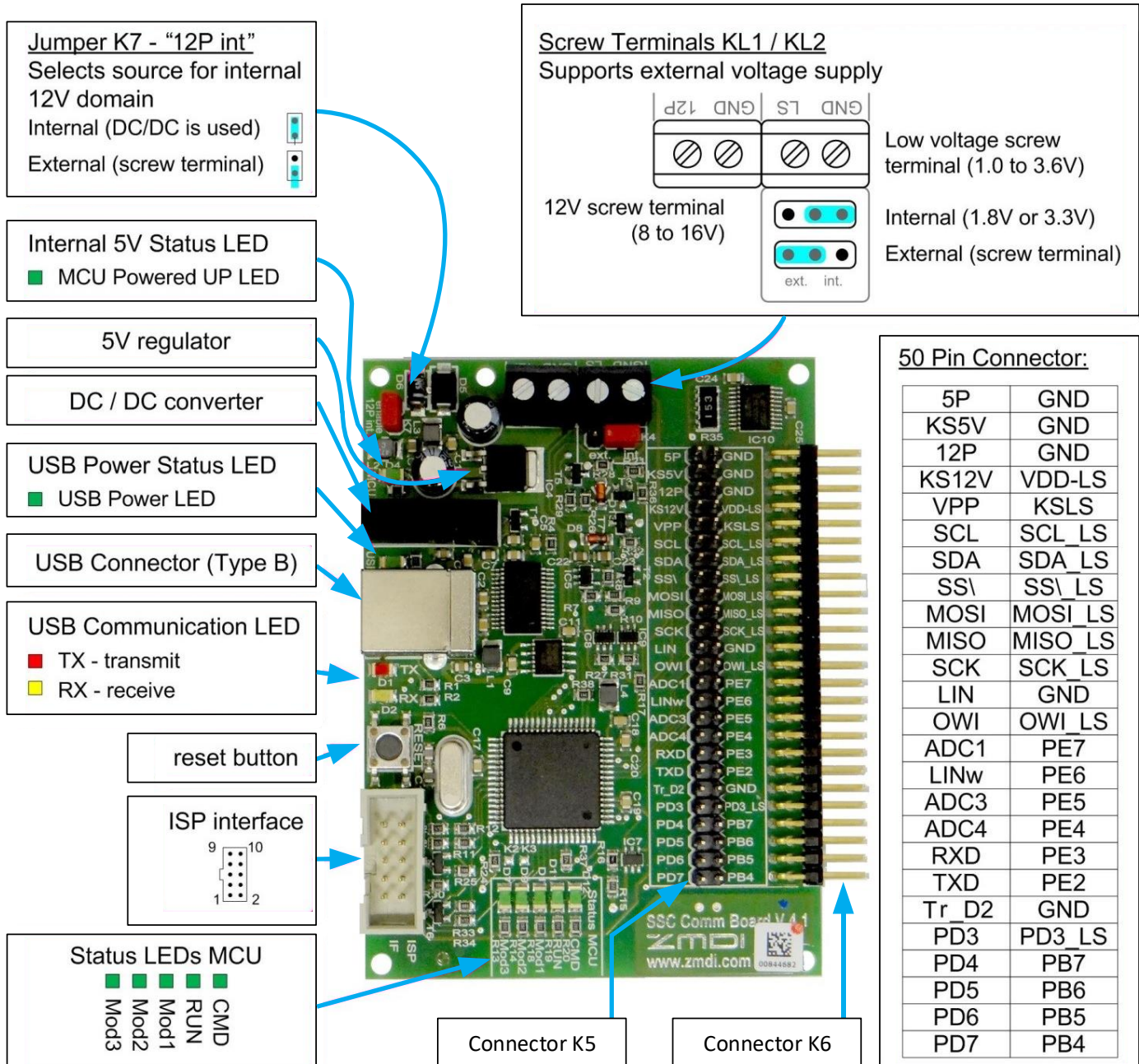

3. Software Installation

Note: To install the SSC Evaluation Software, administrator rights are required on the user's computer.

3.1 System Requirements

- 5x86 compatible computer
- 32MB RAM
- Hard drive with 20MB free space
- Free USB port
- Microsoft Windows® XP / Windows®7 / Windows®8 / Windows®10

3.2 USB Driver Installation

Before installing any SSC IC specific IDT software, the USB driver should be installed. The SSC Communication Board V4.1 uses an FTDI device for communication via the USB port.

- For Windows®XP, the latest driver can be found on FTDI's website (<https://www.ftdichip.com/>). Follow the download and installation instructions on the site.
- If using Windows®7 / Windows®8 / Windows®10, the user's system will automatically download and use the latest approved driver from Microsoft. In this case, ensure that a connection to the internet is established before connecting the SSC Communication Board V4.1 to a free USB port.

The drivers will not affect the operation of any other USB peripherals.

After successful USB driver installation, the software can either use the virtual COM port or the FTDI D2XX.DLL for connection and communication.

4. Circuit Description

4.1 USB Power and the Communication Interface

SSC Evaluation Kits are interfaced to the user's computer via a Universal Serial Bus (USB). The USB communication is handled by an FT232R USB-to-UART IC. The communication to the on-board microcontroller is handled by a common UART line via digital isolators to provide galvanic isolation.

The USB power line supplies the SSC Communication Board via a galvanic isolated 5-to-12V DC/DC converter circuit. Therefore no additional power supply is required. To fulfill the USB specification for devices with more than 100mA power consumption, the supply input of the subsequent circuit is switched by a MOS transistor, which is controlled by the USB-UART-interface IC. As a result, the power supply of the connected microcontroller and SSC Evaluation Board will be switched on after successful USB driver initialization on the computer. The maximum load current of the DC-DC converter's 12VDC output line is 167mA, which is sufficient for supplying the SSC Evaluation Board hardware and some additional external electronic devices. Alternately, it is possible to supply the SSC Evaluation Kit by an external 12VDC power line; e.g., to prevent additional noise caused by the DC-DC converter or to allow more than a 167mA load current at the 12VDC line.

The 5VDC supply line is generated by a common LDO linear regulator supplied by the 12VDC line. The microcontroller (type ATmega1281) handles the communication with the IDT SSC IC by using its specific Evaluation Software running on the user's computer. All serial protocols are implemented in the microcontroller's software (I2C / SPI / LIN / ZACwire™ (OWI One-Wire Interface) / SENT), except that for LIN, a discrete LIN level shifter is used.

The communication status of the microcontroller is displayed by five LEDs. The microcontroller controls both power lines by electronic switches, so a defined power ON/OFF procedure is practicable. A second switchable 12V power supply labeled as VPP is available because it should be used for generation of the required memory programming voltage.

The IDT SSC Evaluation Board can be connected to the SSC Communication Board via the 50-pin connector K6. Additionally, all system signals can be checked via the 50-pin header K5 on the board. This can also be used for connecting external electronics or the user's own hardware.

5. Special Functions of the SSC Communication Board

5.1 Trigger

Most IDT SSC ICs need a special start procedure to switch into the Command Mode. Therefore a special timing and communication procedure after power-on is required. On the SSC Communication Board, this function is provided by the corresponding supply channels (KS5V, KS12V, VPP(12V), and KSLS). All channels are controlled via electronic switches.

To connect user-specified hardware, a separate trigger signal can be provided at the Tr_D2 (Tr_PD2) pin. This trigger signal will be activated by the trigger command. See section 6 for general information on commands, and for a detailed command description, refer to the *SSC Communication Board Command Syntax Spreadsheet*. The *SSC Communication Board Command Syntax Spreadsheet* is included in the firmware update zip folder available on www.IDT.com at www.idt.com/document/swr/ssc-cb-firmware-v414-bootloader-use-communication-board-v41-only.

5.2 Pull-up Resistor for Support of Data Communication

To support reliable data communication, some interfaces (ZACwire™ (OWI One-Wire Interface) and LIN) need an additional pull-up resistor, which is included on the SSC Evaluation Board. To eliminate any parasitics caused by this pull-up resistor on the power supply of the SSC IC and data output pin for the selected SSC IC interface, the pull up resistor must be disconnected from the circuit during the start-up phase. This function is supported by the switchable pin Tr_D2 (Tr_PD2, also see section 5.4). The ZACwire™, OneWire™, and LIN protocol manipulate the signal on Tr_D2 automatically. For user evaluation boards, connect the pull-up resistor or an external pull-up source to Tr_D2.

As an alternative, the SSC Communication Board V4.1 provides an internal 4.7k pull-up for ZACwire™ and OneWire™ interface. By default this pull-up will not be used for communication. The pull-up can be enabled by a special command. See section 6 for general information on commands, and for a detailed command description, refer to the *SSC Communication Board Command Syntax Spreadsheet*.

5.3 ADC Channel ADC0 to ADC4

The SSC Communication Board provides five ADC channels: ADC0 to ADC4. The ADC0 channel is labeled “OWI” (ZACwire™) on connectors K5 and K6 on the board. Note: In OWI Mode, the ADC0 channel is not available for other purposes. The ADC2 channel is labeled “LINw” on connectors K5 and K6. Note: In LIN Mode, the ADC2 channel is not available for other purposes. The ADC channels have a resolution of 10 bits. To use these channels, refer to the SSC Communication Board command descriptions that are given in the *SSC Communication Board Command Syntax Spreadsheet*.

5.4 Digital Channels PB4 to PB7, PD2 to PD7, and PE2 to PE7

The SSC Communication Board provides several bidirectional digital channels PB4 to PB7, PD2 to PD7, and PE2 to PE7. The D2 channel is labeled Tr_D2 on connectors K5 and K6 and Tr_PD2 in the schematic. It is not available during ZACwire™ (i.e., OWI, digital One-Wire Interface) and LIN communication (reserved for pull-up switching as described in section 5.2). The output channels have tri-state functionality. To use these channels, refer to the SSC Communication Board command descriptions in the *SSC Communication Board Command Syntax Spreadsheet*.

5.5 RXD/TXD Interface

The RXD and TXD pins available on the SSC Communication Board’s 50-pin connector (K5/K6) provide the serial protocol that is used for communication between the USB serial connector and the microcontroller.

5.6 LIN Channel

The LIN channel provides a 12V LIN-complaint signal to connect to LIN-compliant devices (LIN specifications 1.3, 2.0, and 2.1). Discrete circuitry converts the 5V microcontroller signal to the 12V LIN level and vice versa. To use this channel, refer to the SSC Communication Board command descriptions in the *SSC Communication Board Command Syntax Spreadsheet*.

5.7 I2C Channel

The I2C communication protocol is provided at the SCL (clock) and SDA (serial data) pins. To use this channel, refer to the SSC Communication Board command descriptions in the *SSC Communication Board Command Syntax Spreadsheet*. On the board, there are pull-up resistors of 4.7kΩ each, which are connected to the switched KS5V power line.

5.8 SPI Channel

The SPI communication protocol is provided at the MOSI (Master Out Slave In), MISO (Master In Slave Out), and SCK (Clock) pins. To use this channel, refer to the SSC Communication Board command descriptions in the *SSC Communication Board Command Syntax Spreadsheet*.

5.9 OWI Channel (ZACwire™)

The ZACwire™ (i.e., OWI, digital One-Wire Interface) communication protocol is provided at the OWI pin on connectors K5 and K6. To use this channel, refer to the SSC Communication Board command descriptions that are given in the *SSC Communication Board Command Syntax Spreadsheet*.

5.10 VPP Pulse Generation

At the VPP pin on connectors K5 and K6, a second 12V power supply can be provided that is intended to be used for a special EEPROM programming pulse generation. However, this VPP pin can also be used for any other 12V purposes. To use this pin, refer to the SSC Communication Board command descriptions in the *SSC Communication Board Command Syntax Spreadsheet*.

5.11 5V Channel

At the 5P pin on connectors K5 and K6, a stabilized voltage of 5VDC is available to supply external circuits. The KS5V channel provides the same voltage, controlled by the microcontroller via an electronic switch, to provide special IC start-up scenarios. To use this channel, refer to SSC Communication Board command descriptions in the *SSC Communication Board Command Syntax Spreadsheet* regarding trigger pulse generation.

5.12 12V Channel

At the 12P pin on connectors K5 and K6, a stabilized voltage of 12VDC is available to supply external circuits if the kit is supplied via USB. When supplying the kit with an 8 to 16 VDC by an external power supply via screw terminal KL1 (see Figure 1), this voltage is available at the 12P pin. The KS12V channel provides the same voltage, as controlled by the microcontroller via an electronic switch to provide special IC start-up scenarios. To use this channel, refer to the SSC Communication Board command descriptions in the *SSC Communication Board Command Syntax Spreadsheet*.

5.13 Level-Shifter Channel

The Communication Board also provides the option to communicate with low-voltage devices using a level shifter. The voltage operation range can be set to fixed internal 1.8V or 3.3V or via KL2 to a freely selectable range of 1.0 to 3.6 VDC.

The control signals for the level shifter and the power supply line are given in the *SSC Communication Board Command Syntax Spreadsheet*.

The level-shifted signals are labeled with “LS” on the K5 and K6 connectors (see Figure 1). At the VDD-LS pin, a stabilized low voltage is available to supply external circuits. The KSLS channel provides the same voltage, controlled by the microcontroller via an electronic switch to provide special IC start-up scenarios.

The I2C, SPI, ZACwire™ (OWI), and one digital channel (PD3) are transferred via the level shifter to the low-voltage domain. If more than one digital channel will be required by the application, the remaining pins of I2C, SPI, or ZACwire™ (OWI) can also be used.

6. SSC Evaluation Kit Controller Language

The SSC Communication Board contains a microcontroller with an 8-bit wide internal RISC processor. The communication between this microcontroller and the user's computer is addressed by a serial protocol. The USB-to-serial converter transforms this signal into a USB-complaint data stream. To allow control of the SSC Communication Board with the user's computer, the USB data is forwarded to a virtual serial interface (virtual COM port) or FTDI D2XX.DLL. This communication is implemented by the USB driver (see section 3.2).

To control the SSC Communication Board, a software interface is necessary. IDT's Evaluation Kits include software that provides this interface.

Alternately, the user's software can be used, or for the simplest cases, a terminal program (e.g., PuTTY) can communicate using the corresponding virtual COM port via defined commands with the SSC Communication Board hardware. The configuration for this method and for all user software is as follows:

- Baud rate: 19200
- Data bits: 8
- Stop bits: 1
- Parity: none
- Command terminator: <Carriage Return> plus optional <Line Feed> (\r\n)*

6.1 SSC Evaluation Kit Controller Language Commands

The commands can be classified as READ, WRITE and SPECIAL commands. Every command that is sent to the hardware is answered by an acknowledge plus a "value" or a not-acknowledge plus a corresponding error code. For the typical IDT SSC IC data structure, refer to the corresponding SSC IC datasheet and/or functional description.

Depending on the type of SSC IC, a special start-up sequence is necessary to switch the IC to the digital communication mode. To handle this sequence, a special trigger command is provided. The trigger values can be selected with a special preparation call. This call configures the channel, which must switch off and on before the first data packet can be sent. The execution of this trigger command can be selected within a subsequent read/write procedure. The switch-off time before a trigger event is executed can also be programmed. The default value is 300ms. The trigger time is related to the command window parameters of each product. Refer to the SSC IC product datasheet for further information.

Table 1. Command Example

Command Description	Command (String)	Command (Hex)
Set the switch-off time to 50ms	T_050	54 5F 30 35 30 0D 0A
Select trigger channel KS5V with a trigger time 10ms	T01010	54 30 31 30 31 30 0A 0D
Write to the I2C channel with trigger	IWT7800101	49 57 54 37 38 30 30 31 30 31 0D 0A
Read a 4-byte value via the I2C port without trigger	ir_78004	69 72 5F 37 38 30 30 34 0D 0A

For a complete command list, refer to the current version of the *SSC Communication Board Command Syntax Spreadsheet*.

Figure 2 illustrates the timing and related trigger signals needed for sending commands to the SSC-CB using the example settings of 50ms switch-off time and 10ms trigger time.

* SSC-CB will interpret CR as the command terminator and will start execution of the command. The string from SSC-CB to the user's computer will always be terminated with <CR><LF>.

Figure 2. Example Start Sequence with Trigger Configuration

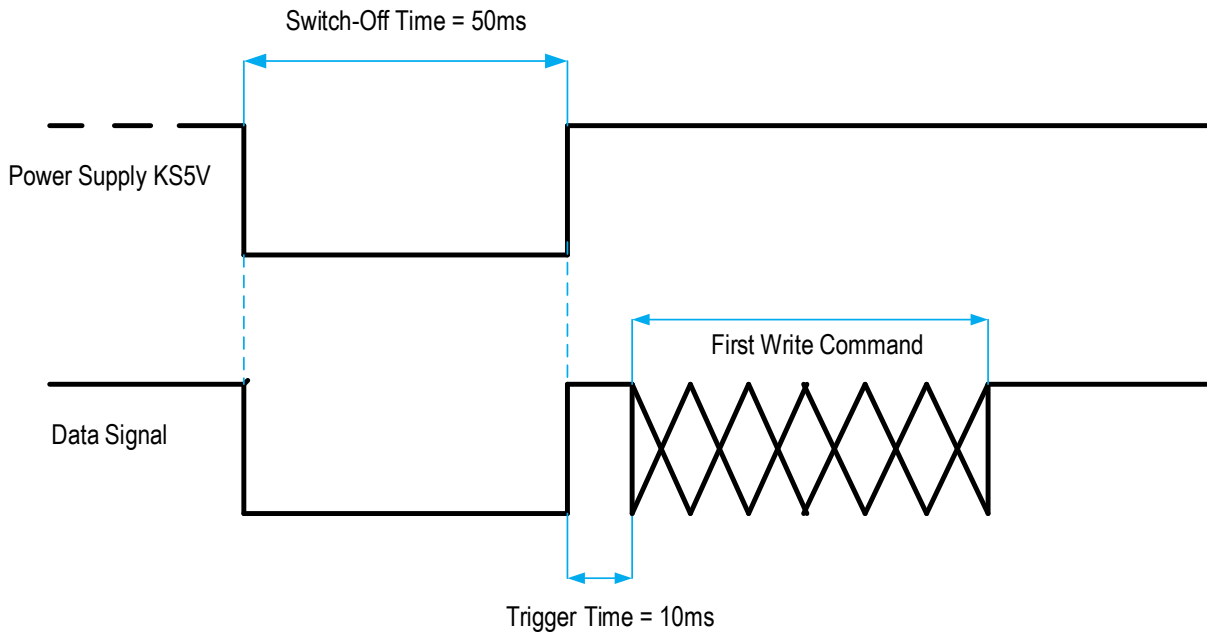

7. SSC Communication Board V4.1 – Schematics

Figure 3. SSC Communication Board V4.1 Schematic Part 1: USB-Interface Circuit

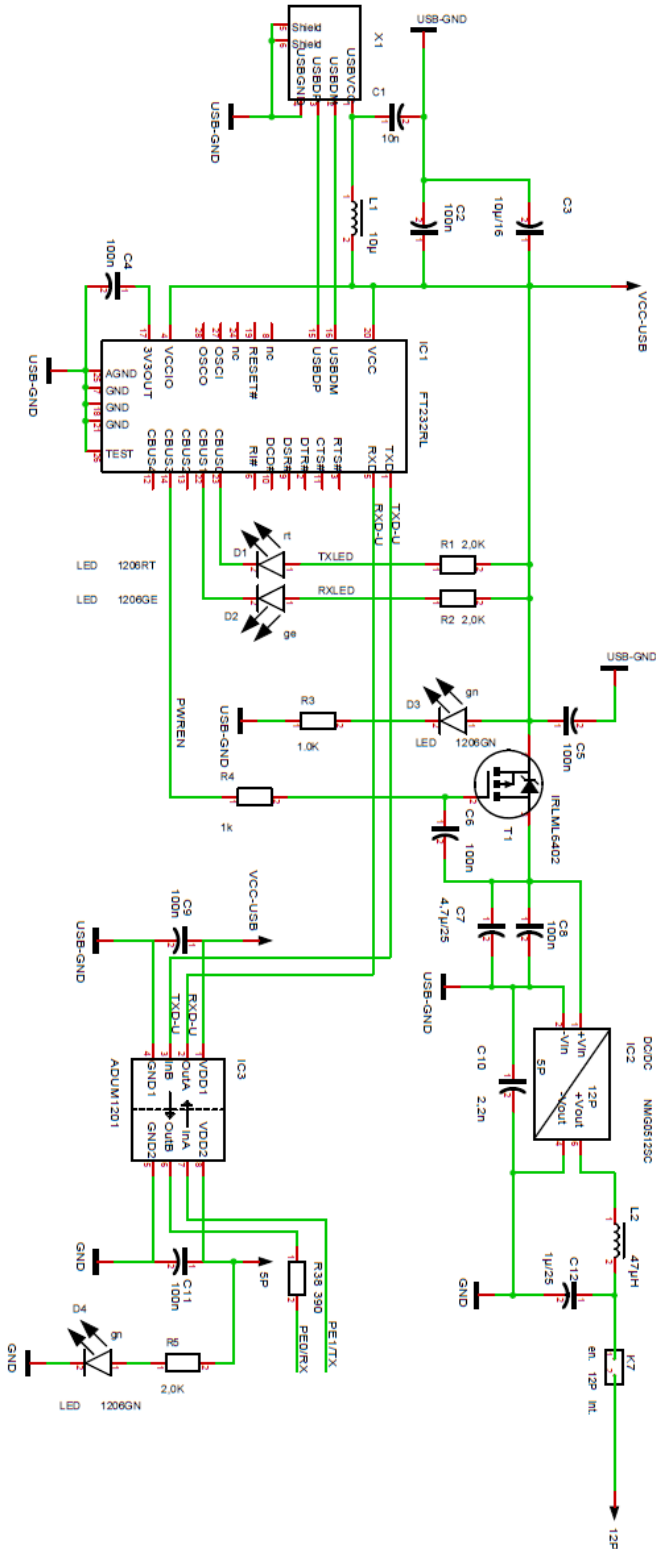
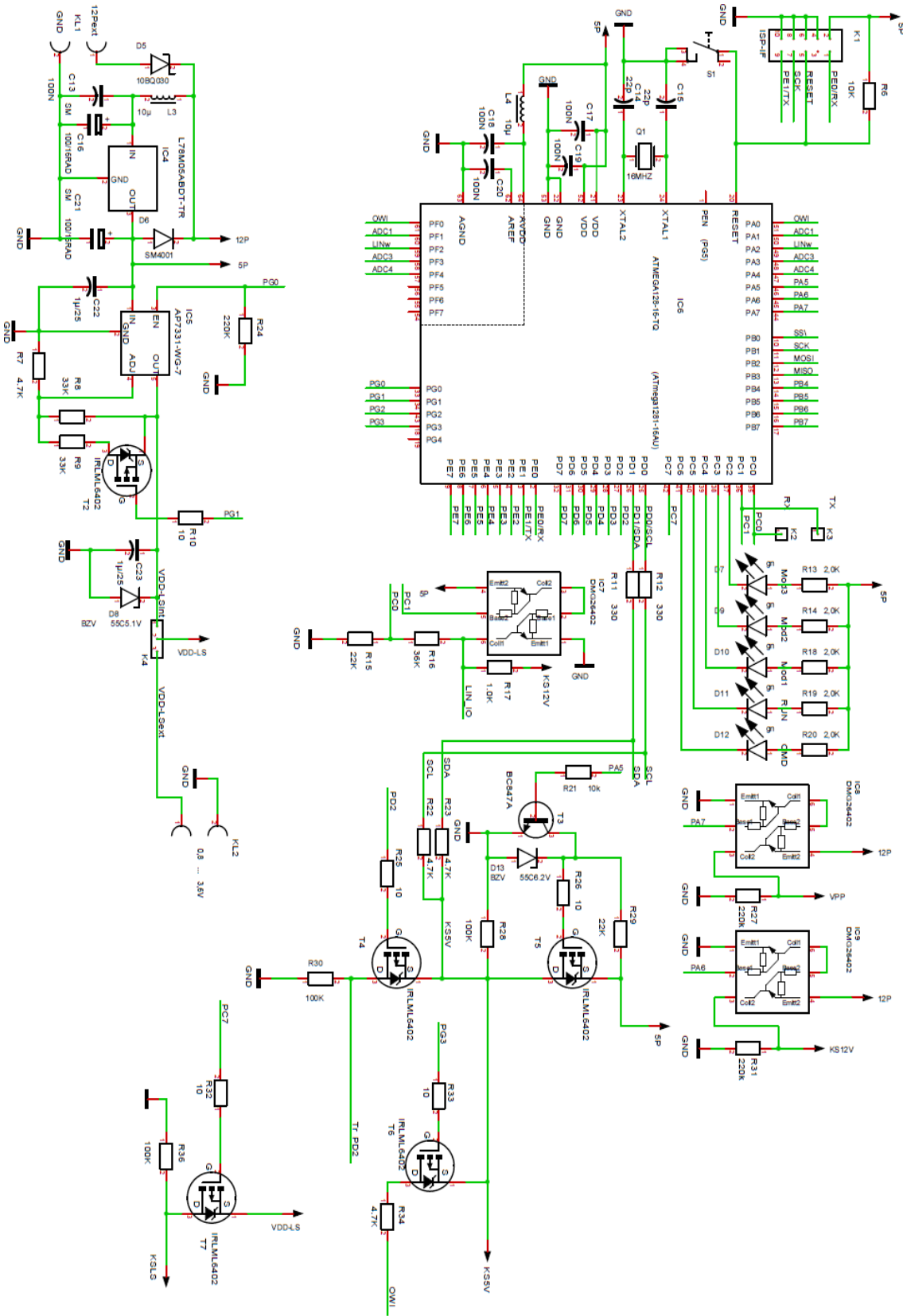

Figure 4. SSC Communication Board Schematic V4.1 Schematic Part 2: MCU Circuit



8. Glossary

Term	Description
ADC	Analog-to-Digital Converter
FTDI	Future Technology Devices International
I2C	Inter-Integrated Circuit (a common two-wire-serial bus system)
ISP	In-Circuit Serial Programming
LDO	Low Drop-Out
LED	Light Emitting Diode
LIN	A common one-wire-serial bus system
LS	Level Shift
MCU	Microprocessor
MISO	Master In Slave Out (signal for the SPI communications interface)
MOSI	Master Out Slave In (signal for the SPI communications interface)
OWI	One-Wire Interface
RX	Receive
SCK	Clock for the SPI communications interface
SCL	Clock for I2C communication interface
SDA	Serial data for I2C communication interface
SPI	Serial Peripheral Interface (a common three-wire-serial bus system)
SS	Slave Select (signal for the SPI communications interface)
SSC	Sensor Signal Conditioner
TX	Transmit
USB	Universal Serial Bus
ZACwire™	An IDT-specific one-wire-serial bus system on a 5V level.

9. Ordering Information

Orderable Part Number	Description
SSCCOMMBOARDV4P1C	SSC Communication Board, Version 4.1 with USB Cable

10. Revision History

Revision Date	Description of Change
April 21, 2019	<ul style="list-style-type: none"> ▪ Update for ZSSC41xx and ZSSC5101 families. ▪ SSC Terminal Program Section removed. ▪ Update for template. ▪ Minor edits.
March 30, 2016	Changed to IDT branding.
November 13, 2013 (Revision 2.00)	Initial release of version for revision 4.1 board.

IMPORTANT NOTICE AND DISCLAIMER

RENESAS ELECTRONICS CORPORATION AND ITS SUBSIDIARIES (“RENESAS”) PROVIDES TECHNICAL SPECIFICATIONS AND RELIABILITY DATA (INCLUDING DATASHEETS), DESIGN RESOURCES (INCLUDING REFERENCE DESIGNS), APPLICATION OR OTHER DESIGN ADVICE, WEB TOOLS, SAFETY INFORMATION, AND OTHER RESOURCES “AS IS” AND WITH ALL FAULTS, AND DISCLAIMS ALL WARRANTIES, EXPRESS OR IMPLIED, INCLUDING, WITHOUT LIMITATION, ANY IMPLIED WARRANTIES OF MERCHANTABILITY, FITNESS FOR A PARTICULAR PURPOSE, OR NON-INFRINGEMENT OF THIRD PARTY INTELLECTUAL PROPERTY RIGHTS.

These resources are intended for developers skilled in the art designing with Renesas products. You are solely responsible for (1) selecting the appropriate products for your application, (2) designing, validating, and testing your application, and (3) ensuring your application meets applicable standards, and any other safety, security, or other requirements. These resources are subject to change without notice. Renesas grants you permission to use these resources only for development of an application that uses Renesas products. Other reproduction or use of these resources is strictly prohibited. No license is granted to any other Renesas intellectual property or to any third party intellectual property. Renesas disclaims responsibility for, and you will fully indemnify Renesas and its representatives against, any claims, damages, costs, losses, or liabilities arising out of your use of these resources. Renesas' products are provided only subject to Renesas' Terms and Conditions of Sale or other applicable terms agreed to in writing. No use of any Renesas resources expands or otherwise alters any applicable warranties or warranty disclaimers for these products.

(Disclaimer Rev.1.0 Mar 2020)

Corporate Headquarters

TOYOSU FORESIA, 3-2-24 Toyosu,
Koto-ku, Tokyo 135-0061, Japan
www.renesas.com

Contact Information

For further information on a product, technology, the most up-to-date version of a document, or your nearest sales office, please visit:
www.renesas.com/contact/

Trademarks

Renesas and the Renesas logo are trademarks of Renesas Electronics Corporation. All trademarks and registered trademarks are the property of their respective owners.