

REVISIONS

P	LTR	DESCRIPTION	DATE	DWN	APVD
	D	Update to new Drawing format	9/11/19	J.B.	T.L.

RAYCHEM HF Tubing SCD

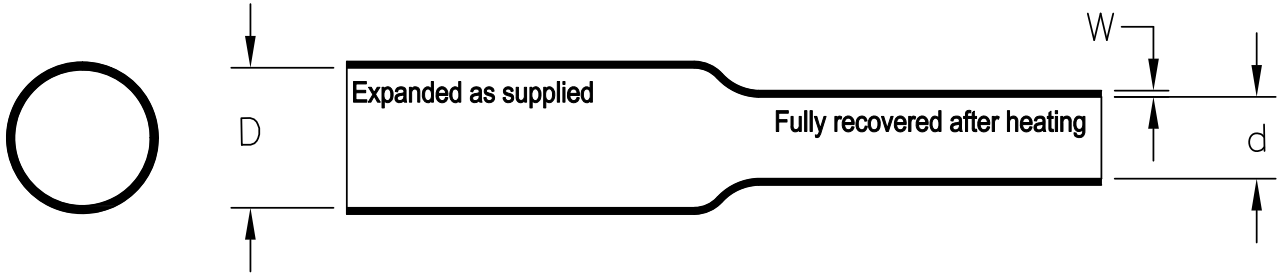

Dimensions mm (inches)

Size	As Supplied		As Recovered	
	Inside Diameter (D)	Inside Diameter (d)	Wall Thickness (W)	
	minimum	maximum	nominal	
HF-04	10.1 (0.400)	3.8 (0.150)	1.8 (0.070)	
HF-07	19.0 (0.750)	5.6 (0.221)	1.8 (0.070)	
HF-11	27.9 (1.100)	9.5 (0.375)	2.7 (0.105)	
HF-13	33.0 (1.300)	9.5 (0.375)	2.7 (0.105)	
HF-15	38.1 (1.500)	12.7 (0.500)	3.0 (0.120)	
HF-17	43.1 (1.700)	12.7 (0.500)	3.0 (0.120)	
HF-20	50.8 (2.000)	19.1 (0.750)	3.6 (0.140)	
HF-27	68.5 (2.700)	22.9 (0.900)	3.9 (0.155)	

**Color:** Standard Black  
Reference Specification 108-120060

THIS DRAWING IS UNPUBLISHED. ALL RIGHTS RESERVED. © COPYRIGHT 2019 TE Connectivity

DIMENSIONS: INCHES	DWN J. Bitter	11-Sep-2019	MATERIAL -	FINISH -
	CHK T. Licko	-	 TE Connectivity	
TOLERANCES UNLESS OTHERWISE SPECIFIED: 0 PLC ± - 1 PLC ± - 2 PLC ± - 3 PLC ± - 4 PLC ± - ANGLES ± -	APVD T. Licko	-		
	PRODUCT SPEC 108-120060	-	SIZE A4	CAGE CODE 06090
	APPLICATION SPEC -	-	DRAWING NO C=HF	RESTRICTED TO -
	WEIGHT 0		CUSTOMER DRAWING	SCALE 1:1
				SHEET 1 OF 1
				REV D