

POSSIBLE MARKING CONFIGURATIONS
SCALE 5:1

- 1 MATERIAL: HEADER- POLYESTER UL94V-0 (BLACK)
POST- COPPER ALLOY.
- 2 SOLDER SIDE OF P.C. BOARD SHOWN.
- 3 PARTS COMPLY WITH AMP SOLDERABILITY SPEC 109-11-12.
- 4 ONE HOLE MAY BE UNDERSIZED (.032-.035 DIA) FOR ASSEMBLY RETENTION DURING WAVE SOLDERING.
- 5 LATCH DETENT FEATURE OCCURS 2 PLACES ON EACH END (MAXIMUM OF FOUR PER PART). FOR 2 THRU 5 CIRCUIT HEADERS, LATCH FEATURE OCCURS BETWEEN EACH CIRCUIT.
- 6 COORDINATE DIMENSION APPLIES FROM CENTER OF ACTUAL FEATURE.
- 7 POST: 100% MATTE TIN PLATED.
- 8 POST MUST WITHSTAND 3.0 LBS (13 NEWTONS) MIN FORCE WITHOUT DISLODGING, EITHER DIRECTION.
- 9 UL AND CSA LOGO WILL APPEAR IN THIS AREA. AMP LOGO MAY APPEAR IN THIS AREA OR ON BOTTOM OF PART.
- 10 TWO SIDES OF TAPER, AS SHOWN, MUST BE PLATED. TYPICAL, BOTH ENDS.
- 11 TWO SIDES OF TAPER, AS SHOWN, AND TIP MAY BE UNPLATED. TYPICAL, BOTH ENDS.
- 12 POST: MATTE TIN-LEAD (93/7) PLATED.
- 13 OBSOLETE PART NUMBER.

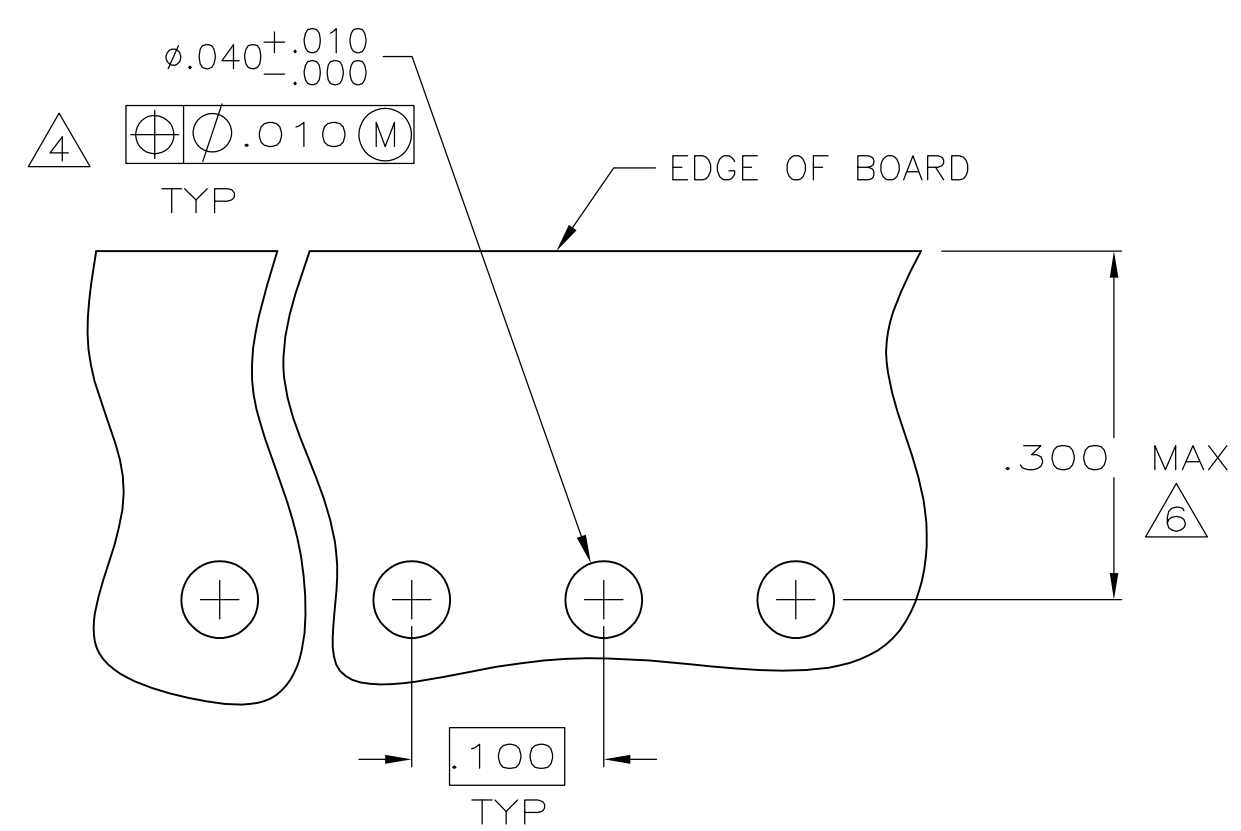
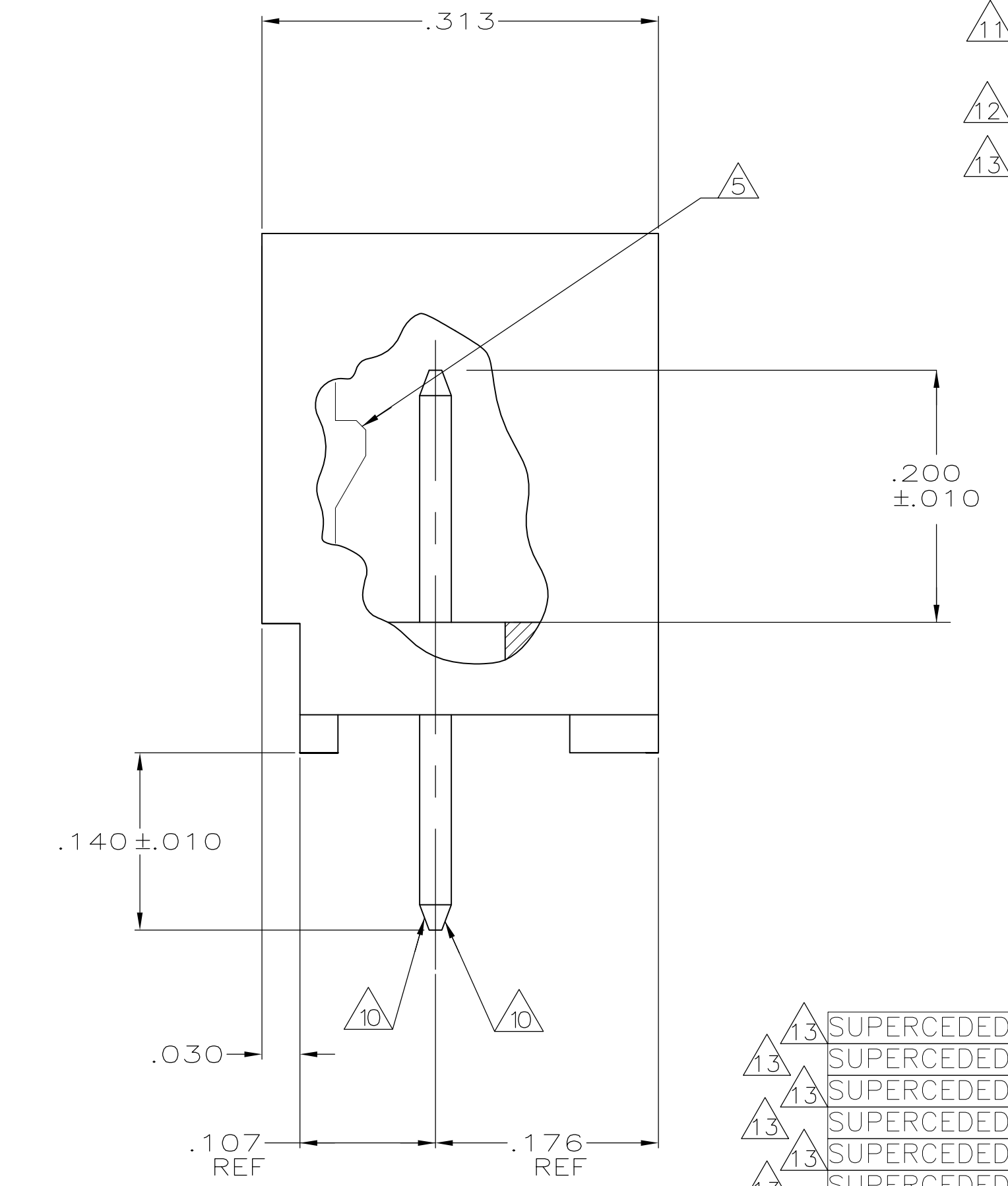
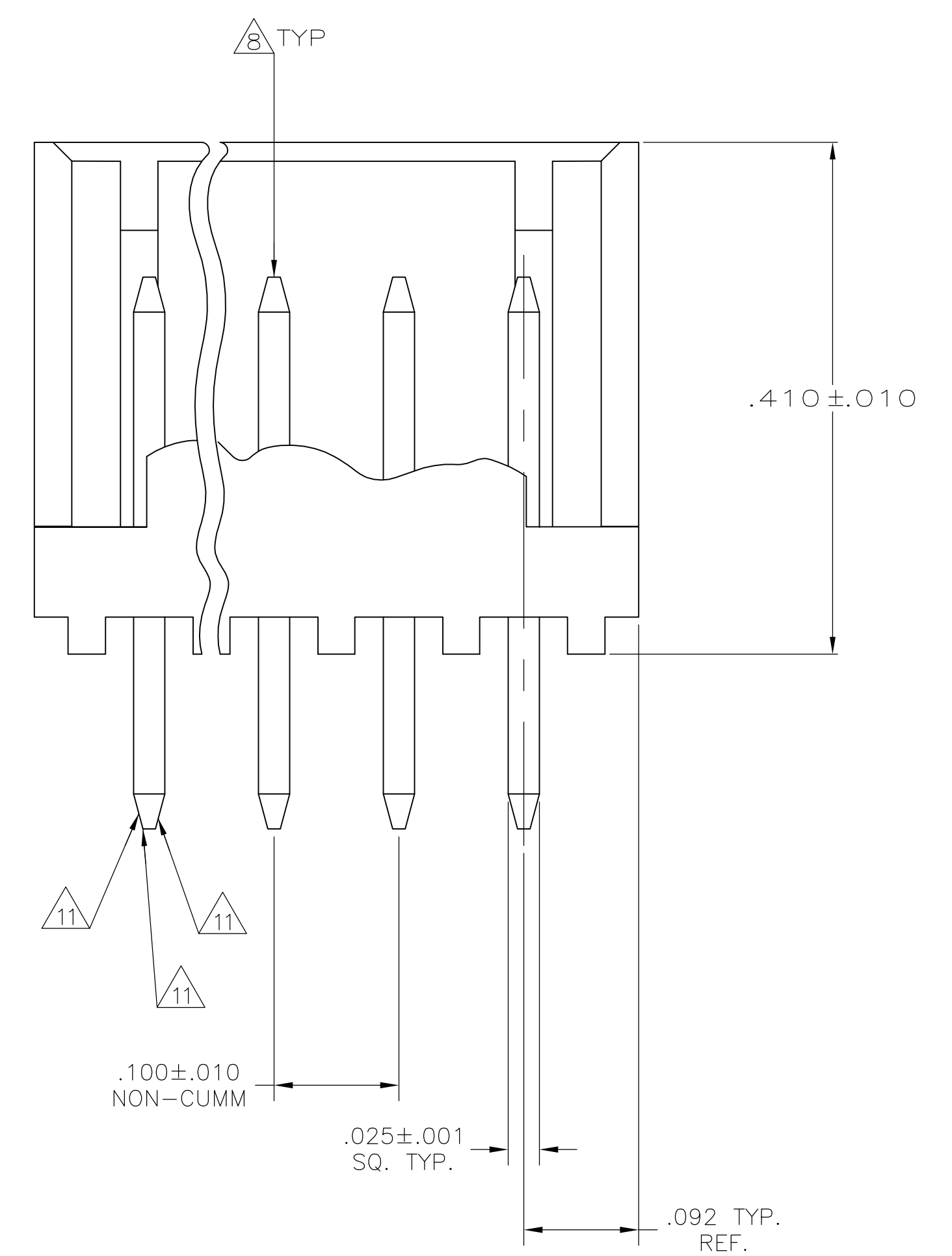

RECOMMENDED MOUNTING HOLE PATTERN FOR .063 THK PRINTED CIRCUIT BOARD

.035	0.89	.176	4.47	-	-
.032	0.81	.140	3.56	-	-
.030	0.76	.107	2.72	-	-
.025	0.64	.100	2.54	-	-
.010	0.25	.092	2.34	.410	10.41
.005	0.13	.063	1.6	.313	7.95
.001	0.03	.050	1.27	.300	7.62
.000	0	.040	1.02	.200	5.08
IN	MM	IN	MM	IN	MM

CONVERSION TABLE

13	SUPERCEDED BY 3-644861-4
13	SUPERCEDED BY 3-644861-3
13	SUPERCEDED BY 3-644861-2
13	SUPERCEDED BY 3-644861-1
13	SUPERCEDED BY 3-644861-0
13	SUPERCEDED BY 2-644861-9
13	SUPERCEDED BY 2-644861-8
13	SUPERCEDED BY 2-644861-7
13	SUPERCEDED BY 2-644861-6
13	SUPERCEDED BY 2-644861-5
13	SUPERCEDED BY 2-644861-4
13	SUPERCEDED BY 2-644861-3
13	SUPERCEDED BY 2-644861-2

YES	7	1.484	37.69	14	3-644861-4
		1.384	35.15	13	3-644861-3
		1.284	32.61	12	3-644861-2
		1.184	30.07	11	3-644861-1
		1.084	27.53	10	3-644861-0
		.984	24.99	9	2-644861-9
		.884	22.45	8	2-644861-8
		.784	19.91	7	2-644861-7
		.684	17.37	6	2-644861-6
		.584	14.83	5	2-644861-5
		.484	12.29	4	2-644861-4
		.384	9.75	3	2-644861-3
		.284	7.21	2	2-644861-2
NO	12	1.484	37.69	14	1-644861-4
		1.384	35.15	13	1-644861-3
		1.284	32.61	12	1-644861-2
		1.184	30.07	11	1-644861-1
		1.084	27.53	10	1-644861-0
		.984	24.99	9	644861-9
		.884	22.45	8	644861-8
		.784	19.91	7	644861-7
		.684	17.37	6	644861-6
		.584	14.83	5	644861-5
		.484	12.29	4	644861-4
		.384	9.75	3	644861-3
		.284	7.21	2	644861-2

LEADFREE	FINISH	IN	MM	NO OF POSITIONS	PART NUMBER
		L		HEADER ASSEMBLY	

THIS DRAWING IS A CONTROLLED DOCUMENT.

DIMENSIONS: INCHES TOLERANCES UNLESS OTHERWISE SPECIFIED:

0 PLC	± .005
1 PLC	± .005
2 PLC	± .005
3 PLC	± .005
4 PLC	± .005
ANGLES	± .005

MATERIAL: 1 FINISH: SEE TABLE

WEIGHT: A1 00779

CUSTOMER DRAWING

DIN S. CARPENTER 28MAY2003
CHK: D. BOSSI 28MAY2003
APP'D: D. BOSSI 28MAY2003
NAME: MTA-100 SHROUDED HEADER ASSEMBLY, FRICTION LOCK, STRAIGHT POST, TIN OR TIN LEAD PLATED

SIZE: A1
SCALE: 10:1
SHEET: 1 OF 1
REV: N

