

Material:

- Contacts: Phosphor Bronze
- Insulator: PBT
- Shell: Brass

Mechanical:

- Mating: 35N Max.
- Withdrawal Force: 10N Min.
- Durability: 1,500 Cycles Min.

Electrical:

- Current - Max(Amps): 1.5A
- Voltage - Max(Volts): 30V
- Withstanding voltage: 500V AC
- Contact Resistance: 30MΩ Max.
- Insulation Resistance: 1,000MΩ Min.

Plating:

- Contacts: 5μ" gold plating
- Shell: Nickel over all plating

Environmental:

- Temperature: -55°C ~ +50°C
- Soldering Temperature: 223.3°C Max.

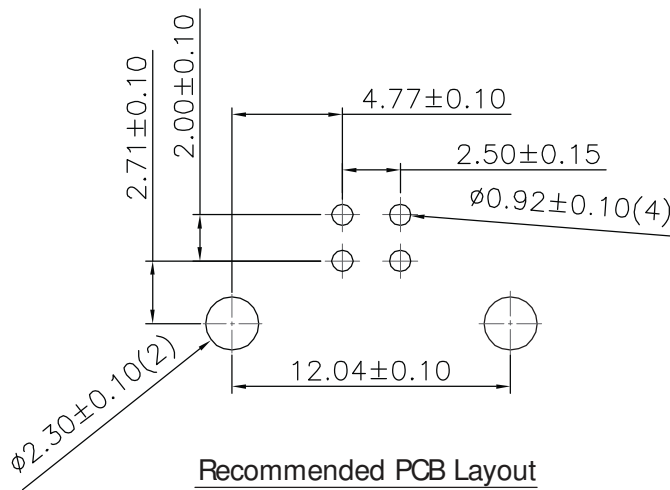
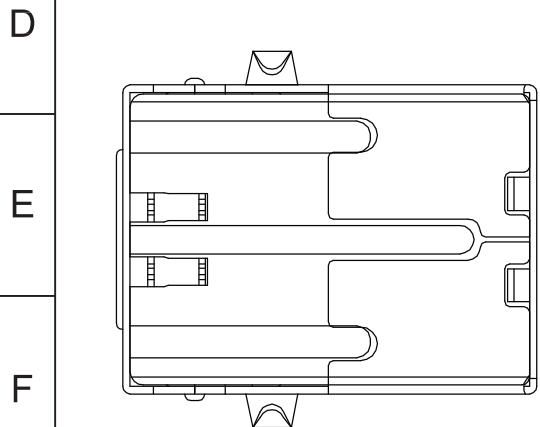

Recommended PCB Layout

Unit: mm



Scale	1:1					Date	Name	Title USB 1.1 Connector - Type B PCB Mounting, 5μ" Gold, White Insulator
TOLERANCE						Drawn	Chappell	
X.X	±0.40					Approved	Skinner	ASSMANN WSW-No.
X.XX	±0.25							AU-Y1007-R
X.XXX	±0.15							Drawing-No.
DIM	TOL							rev01
X.°	±3°							Replace
X.X°	±X°	①	Changed Insulator: LCP+30% GF, UL94-V-0, Black to PCB Changed Temperature Range from -55°C~+85°C to -55°C~+50°C	01.04.12	Chappell			Sheet
Angle	TOL	Id.	Modification	Date	Name	 1840 W. Drake Drive, Suite 101 • Tempe, AZ 85283 Toll Free: 1-877-277-6266 • Email: info@assmann.us		1/1

1

2

3

4

5

6

7