

Buck Pulse Width Modulator Stepdown Voltage Regulator

FEATURES

- Provides Simple Single Inductor Buck PWM Step-Down Voltage Regulation
- Drives External High Side NMOS Switch
- 14V to 72V Input Voltage Operating Range
- Contains 100kHz Internal Oscillator, 2V Reference and UVLO
- Soft Start on Power Up
- Overcurrent Shutdown Followed by Soft Start

DESCRIPTION

The UC3578 is a PWM controller with an integrated high side floating gate driver. It is used in buck step down converters and regulates a positive output voltage. Intended to be used in a distributed power system, the IC allows operation from 14V to 72V input voltage which range includes the prevalent telecomm bus voltages. The output duty cycle of the UC3578 can vary between 0% and 90% for operation over the wide input voltage and load conditions.

The UC3578 simplifies the design of the single switch PWM buck converter by incorporating a floating high side driver for an external N-channel MOSFET switch. It also features a 100kHz fixed frequency oscillator, an internal 2V precision reference, an error amplifier configured for voltage mode operation, and a PWM comparator with latching logic. Complementing the traditional voltage mode control block, the UC3578 incorporates an overcurrent shutdown circuit with full cycle soft re-start to limit the input current to a user defined maximum value during overload operation. Additional functions include an under voltage lockout circuit to insure that sufficient input supply voltage is present before any switching activity can occur.

The UC2578 and the UC3578 are both available in surface mount and thru-hole power packages.

ORDERING INFORMATION

	TEMPERATURE RANGE	PACKAGE
UC2578DP	-40°C to +85°C	Power SOIC
UC2578N		Power PDIP
UC3578DP	0°C to +70°C	Power SOIC
UC3578N		Power PDIP

TYPICAL APPLICATION DIAGRAM

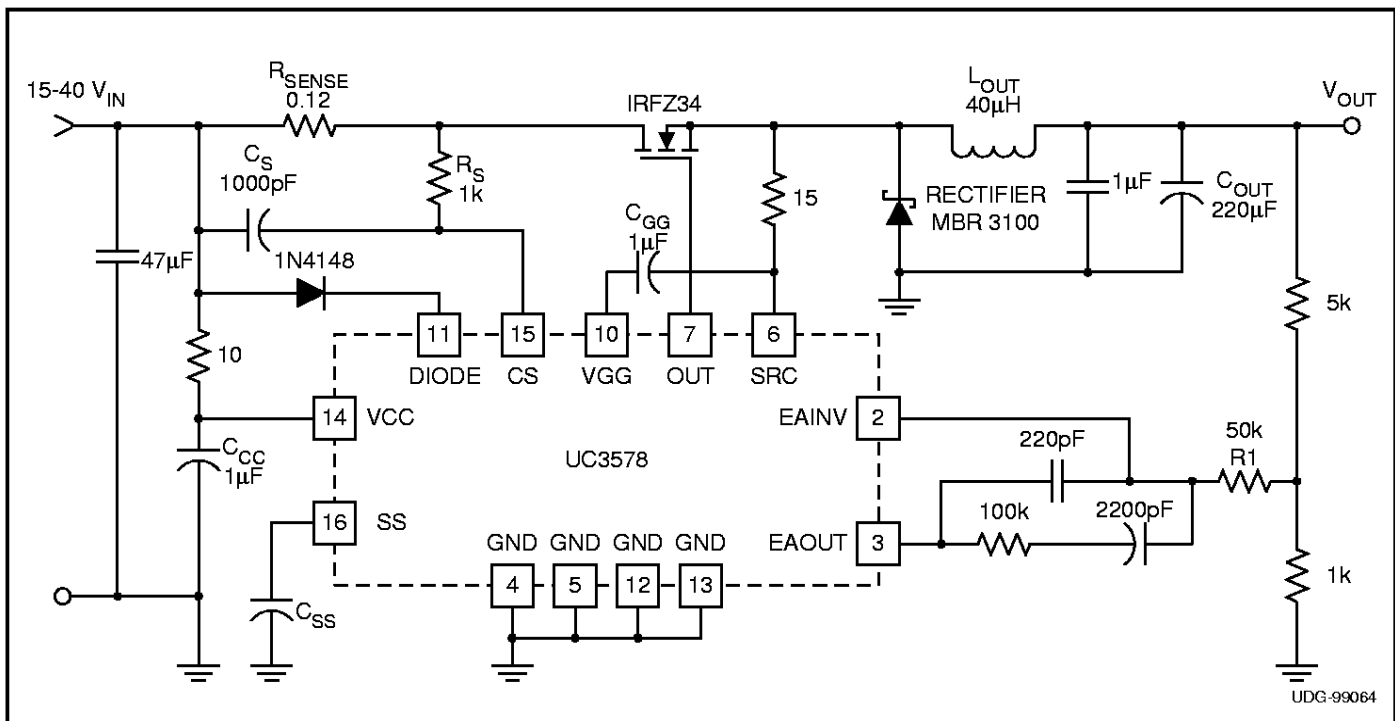

ABSOLUTE MAXIMUM RATINGS

VCC	+72V
EAINV	-0.3V to +10V
EAOUT	-0.3V to +10V
SS	-0.3V to +10V
DIODE	-0.3V to VCC
VGG	-0.3V to VCC +14V
CS	VCC - 5V to VCC +0.6V
I _{OUT} Pulsed	-0.8A to +0.6A
SRC	-0.6V to VCC
Storage Temperature	-65°C to +150°C
Junction Temperature	-55°C to +150°C
Lead Temperature (Soldering, 10 sec.)	+300°C

Currents are positive into, negative out of the specified terminal.
Consult Packaging Section of Databook for thermal limitations and considerations of packages.

CONNECTION DIAGRAM

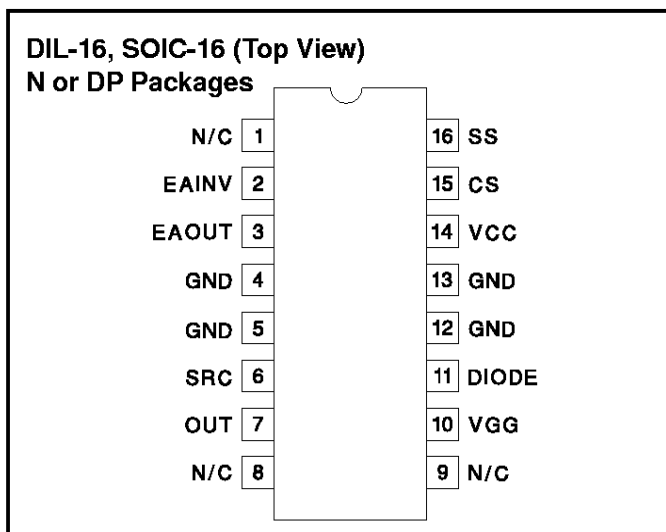

Note: The four GND pins are internally connected.

ELECTRICAL CHARACTERISTICS: Unless otherwise specified VCC = 14V, VGG = 14V, T_A = T_J.

PARAMETER	TEST CONDITIONS	MIN	TYP	MAX	UNITS
Oscillator Section					
Frequency	VCC = 14V to 72V, EAINV = 1.9V, T _J = 25°C	100	110	120	kHz
	VCC = 11V to 14V, Over Temperature	90		120	
Error Amplifier Section					
EAINV	EAOUT = EAINV	1.97	2	2.03	V
I _{EAINV}	EAOUT = EAINV		100	300	nA
EAVOL	EAOUT/EAINV, 25°C	70	80		dB
EAOUT High	EAINV ≤ 1.9V, I _{EAOUT} = -100μA	5.5	6.2		V
EAOUT Low	EAINV ≥ 2.1V, I _{EAOUT} = 100μA		0.8	1.1	V
Unity Gain Bandwidth	T _J = 25°C, F = 100kHz	0.85	1		MHz
PSRR, EAOUT	EAOUT = EAINV, VCC = 14V	80	90		dB
Current Sense Comparator Section					
Threshold (Referred to VCC)		0.4	0.5	0.6	V
Input Bias Current	CS = VCC - 0.4V		0.2	1	μA
Propagation Delay	V _{OVERDRIVE} = 250mV		0.7	1.2	μs
Blanking Time	V _{OVERDRIVE} = 250mV	75	200	300	ns
Gate Drive Output Section					
VOH	I _{OUT} = -200mA	9.5	11		V
VOL	I _{OUT} = 20mA		0.2	0.36	V
	I _{OUT} = 200mA		1.5	2	V
Rise Time	T _J = 25°C, Q _{LOAD} = 1nF		40	70	ns
Fall Time	T _J = 25°C, Q _{LOAD} = 1nF		40	70	ns
Pulse Width Modulator Section					
Maximum Duty Cycle	EAINV ≤ 1.9V	85	90		%
Minimum Duty Cycle	EAINV ≥ 2.1V		0		%
Modulator Gain	EAOUT = 2.5V to 3.5V		30		%/V
Undervoltage Lockout Section					
Start Threshold	OUT - SRC, EAINV ≤ 1.9V, SRC = 0V	10	11	12	V
UVLO Hysteresis		1.5	2	2.5	V

ELECTRICAL CHARACTERISTICS: Unless otherwise specified VCC = 14V, VGG = 14V, T_A = T_J.

PARAMETER	TEST CONDITIONS	MIN	TYP	MAX	UNITS
VGG Regulator Section					
VGG – SRC	VCC = 72V, SRC = 0V, I _{VGG} = –7mA	14.5	15.25	17	V
	VCC = 50V, SRC = 0V, I _{VGG} = –7mA	14	14.75	16	V
	VCC = 15V, SRC = 0V, I _{VGG} = –7mA	13	13.75	14.5	V
	VCC = 11V, SRC = 0V, I _{VGG} = –7mA	9.5	10	10.5	V
Soft Start Ramp Section					
Soft Start Ramp Current		–30	–45		μA
Supply Current Section					
I _{VCC}	EAINV ≥ 2.1V, SRC = 0V		10	14	mA
I _{VGG}	EAINV ≥ 2.1V, SRC = 0V		7	10.5	mA

PIN DESCRIPTIONS

CS: Peak current limit sense pin. Senses the current across a current sense resistor placed between VCC and the drain of the NMOS buck switch. OUT will be held low (NMOS buck switch off) if VCC – CS exceeds 0.5V.

DIODE: An external small signal diode (1N4148 typical) is connected here, anode to VCC and cathode to DIODE, to implement the VGG regulator function.

EAINV: Inverting input to error amplifier. V_{OUT} sense feedback is connected to this pin. The non-inverting input of the error amplifier is internally connected to 2V.

EAOUT: Output of the error amplifier. Use EAOUT and EAINV for loop compensation components.

GND: Circuit Ground. The four ground pins are internally connected together by the fused leadframe of the package. They provide the primary thermal conduction path for dissipating junction heat.

OUT: Gate drive for the external NMOS switch connected between VCC and the buck inductor.

SRC: This pin is connected to the junction of the external NMOS switch source, the floating voltage source capacitor, the free-wheeling diode cathode, and buck inductor.

SS: The external soft start capacitor is connected to this pin.

VGG: An external capacitor connected from VGG to SRC completes the floating voltage source for the floating gate driver. A 1μF capacitor is recommended.

VCC: Input supply voltage. This pin supplies an internal ground referenced voltage regulator that supplies the IC and an on-chip regulated floating voltage source (VGG – SRC) used by the floating driver to drive the external NMOS buck switch. This pin should be bypassed with a high quality ceramic capacitor.

APPLICATION INFORMATION

The UC3578 Floating Buck Controller is a high frequency switching regulator with a floating driver which provides PWM control for non-isolated buck converters. The controller operates at a fixed 100 kHz switching frequency, and in voltage mode control. The duty cycle range of the PWM output is 0% to 90% allowing for a wide range of input voltages (14V minimum with transients to 72V). The regulator features an undervoltage lockout threshold of 11V with approximately 2V hysteresis as well as soft start capability. The typical application circuit shown is for a 15V to 40V input and a 12V at 3A output.

To ensure proper operation of the floating driver, an external capacitor (1μF ceramic) must be connected from VGG to SRC, and to the source of the external MOSFET

through a small resistor, as shown in the typical application diagram and in Fig 2. This capacitor provides the energy for the high side driver. The gate drive voltage to the MOSFET is internally regulated to 14V. A diode (1N4148) is required from the input voltage to DIODE. This allows the floating drive capacitor to charge during conduction of the output rectifier but prevents its discharge back into the supply rail. A 1μF ceramic capacitor is recommended from VCC to ground to provide high frequency decoupling. Additional decoupling of this pin could be accomplished by a low value resistor between VCC and V_{IN} and a 1μF capacitor from VCC to GND as shown in the schematic.

APPLICATION INFORMATION (cont.)

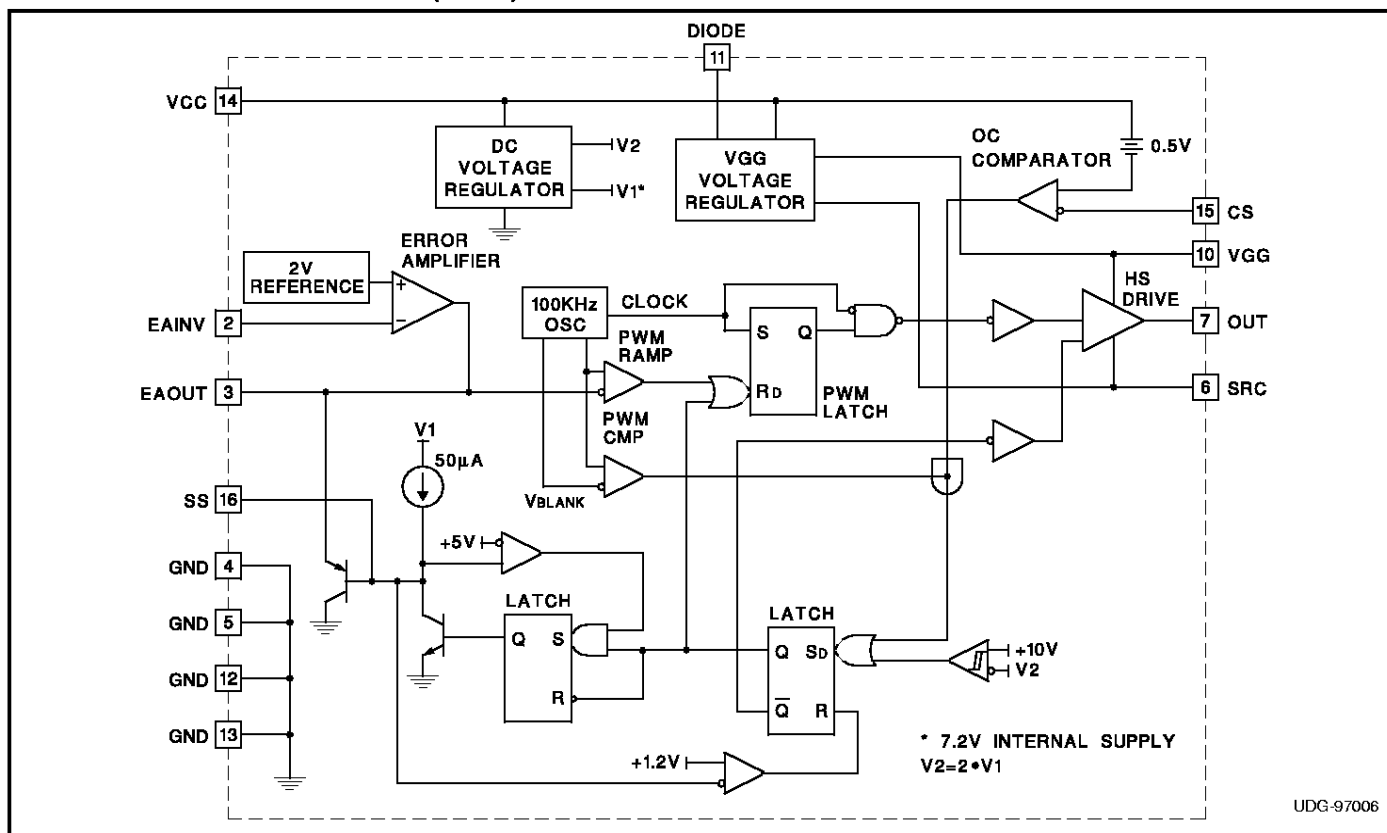

Figure 1. Block diagram.

Current Limit

The current sense pin provides overcurrent shutdown. As can be seen from the block diagram, the overcurrent comparator is wire ANDed with the oscillator after an internally set blanking time. The I_{LIMIT} threshold level is set by the current sense resistor from R_{SENSE} .

$$I_{LIMIT} = \frac{0.5V}{R_{SENSE}}$$

An optional filter can be added ($R_S C_S$) from the current sense resistor to CS to provide high frequency filtering of the current sense signal if necessary.

During a current limit condition, the soft start capacitor on SS is discharged until its voltage level reaches 1.2V. During this time, a duty cycle clamp is activated to approximately 0.6V above the voltage level on the SS capacitor. This condition persists until the SS capacitor is discharged to 1.2V, thus disabling the output driver. At this time, the SS capacitor is allowed to charge to 5V through the 50µA current source and normal operation resumes when the SS capacitor reaches 5V. During the condition described, the regulator enters a hiccup current limit mode of operation which limits the power dissipation in the MOSFET and output rectifier under a short circuit condition.

Error Amplifier

The onboard error amplifier of the UC3578 is a voltage amplifier with its non-inverting input tied to an internal 2V reference. As usual, loop compensation can be added from the inverting input of EAINV to the error amplifier output at EAOUT. Consideration must be given when choosing the values of the compensation components around the amplifier so that the output swing of the amplifier is not restricted. The output of the amplifier can source 100µA typically.

General

As in any buck converter, when the switch is off, the source flies low due to the conduction of the free-wheeling rectifier. The source (SRC) is pulled below ground by an amount determined by the forward voltage drop of the rectifier and by any transient voltage spike from inductance in this path. The occurrence of this condition could result in erratic operation of the IC during this period if the negative excursion is not limited. This is because of conduction of current in the substrate of the IC due to the source pin being pulled below ground and forward biasing the internal substrate PN junction. To limit this effect, a small resistor (15Ω) can be placed in series between the MOSFET source and the SRC pin as shown in Fig. 1. Too large a resistor will limit the drive to the

APPLICATION INFORMATION (cont.)

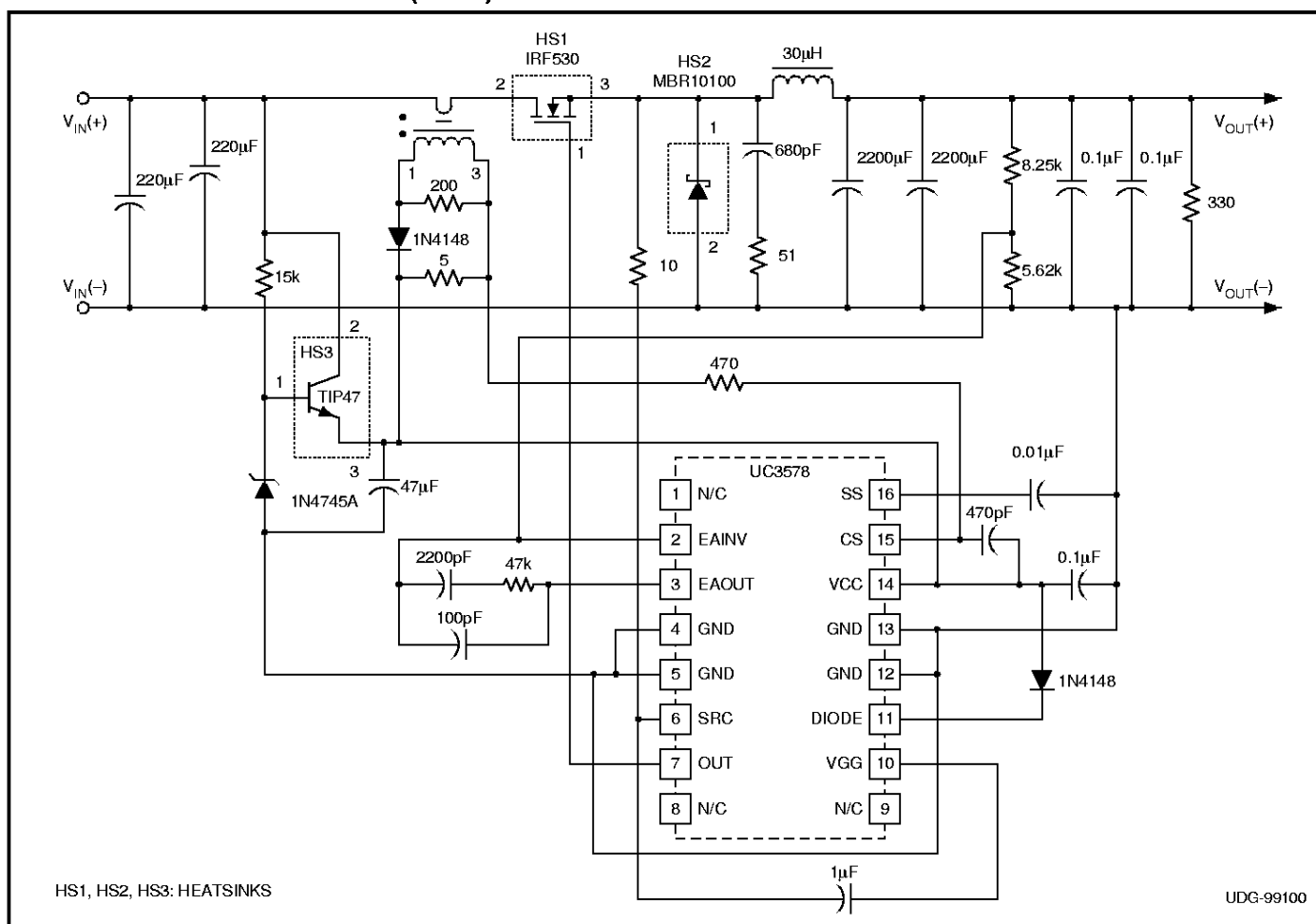

Figure 2. Detailed application schematic for the UC3578 evaluation board.

MOSFET and result in startup problems with the regulator. A Schottky rectifier is used for the free-wheeling diode to limit the negative excursion of the source. This will also limit the reverse recovery current thus limiting the inductive voltage spike.

In applications where transient load excursions may result in a no load condition, it is necessary that the output of the regulator be loaded with a small load current (10mA to 15mA). This will prevent the output voltage from going unregulated at no load. This small load current is necessary for proper operation of the floating driver since the source must fly low to charge up the floating driver capacitance.

Thermal Considerations

For proper operation and reliability of the UC3578, proper thermal management is essential. It is important that the designer keep in mind that with surface mount packages, a significant amount of the heat that the device generates is conducted out through the lead frame. Because of this, the PCB design becomes a critical part

of the thermal management system. Worst case junction-to-ambient thermal resistance for different package configurations are given in a table in the data book in the package information section.

The maximum ambient operating temperature is an important factor in determining what the maximum operating voltage can be for a particular application. For example, if we assume a maximum operating ambient temperature of 70°C we can determine what the maximum allowable input voltage can be given other parameters such as package thermal impedance and MOSFET total gate charge by following the procedure outlined below;

$$T_{J(max)} - T_A = 125^\circ C - 70^\circ C = 55^\circ C. \tag{1}$$

$$Pd = \frac{55^\circ C}{58^\circ C / W} = 0.95W, \tag{2}$$

where 58°C/W is the worst case theta j-a for the 16 pin DP package and Pd is the package power dissipation.

APPLICATION INFORMATION (cont.)

$$Pd = (Qg \cdot 100kHz + 19mA) \cdot V_{IN}, \quad (3)$$

where Qg is the total MOSFET gate charge and 19mA is the maximum quiescent current for the UC3578 ($I_{CC} + I_{GG}$) from the data sheet. The switching frequency of the buck converter is 100kHz.

The gate charge can be determined from the MOSFET data sheet. As an example, for a IRFZ34 which has a total gate charge of 46nC, substituting for Pd in equation 3:

$$0.95W = (46nC \cdot 100kHz + 19mA) \cdot V_{IN}, \text{ and}$$

$$V_{IN(max)} = \frac{0.95W}{0.0236A} = 40V.$$

Therefore, at 70°C using a IRFZ34 MOSFET the maximum input voltage is limited to 40V to maintain a maximum junction temperature of 125°C in the 16 pin DP package.

Higher input voltages can be achieved by choosing a MOSFET with a lower total gate charge or by a reduced ambient operating temperature or by reducing the theta

j-a of the package by improving the PCB mounting method. It is recommended that the four GND pins (4, 5, 12 and 13) be connected to a ground plane to provide a low resistance thermal path. If a ground plane is not available, a heat spreader on a double sided PC board is recommended.

Note: Thermal impedance number is based on device mounted to 5 square inch FR4 PC board with one ounce copper. From Unitrode 95-96 data book Table 1, page 9-8, when resistance range is given, lower thermal impedance values are for 5 square inch aluminum PC board.

ADDITIONAL INFORMATION

Please refer to the following Unitrode topic for additional application information.

[1] Application Note U-167, *Design and Evaluation of a 48V to 5V Telecom Buck Converter using the UC3578 Control IC* by Mark Dennis.

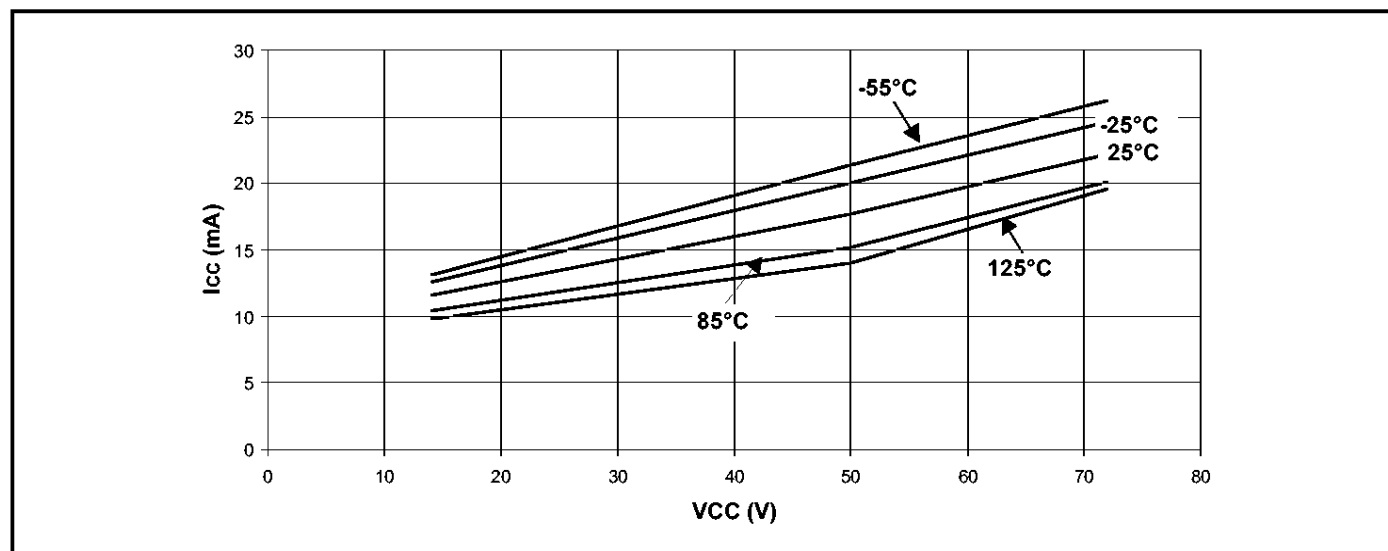

Figure 3. I_{CC} vs. V_{CC} vs. temperature.