

Major Ratings and Characteristics

Characteristics	1N6392	Units
$I_{F(AV)}$ Rectangular waveform	60*	A
V_{RWM}	45*	V
I_{FSM} @ 60Hz	1000*	A
V_F @ 60Apk, $T_J = 25^\circ\text{C}$	0.68*	V
T_J range	-55 to 175*	$^\circ\text{C}$

* JEDEC Registered Values

Description/ Features

The 1N6392 Schottky rectifier has been optimized for low reverse leakage at high temperature. The proprietary barrier technology allows for reliable operation up to 175° C junction temperature. Typical applications are in switching power supplies, converters, free-wheeling diodes, and reverse battery protection.

- 175° C T_J operation
- Low forward voltage drop
- High frequency operation
- Guard ring for enhanced ruggedness and long term reliability
- Hermetic packaging
- Military qualified versions also available

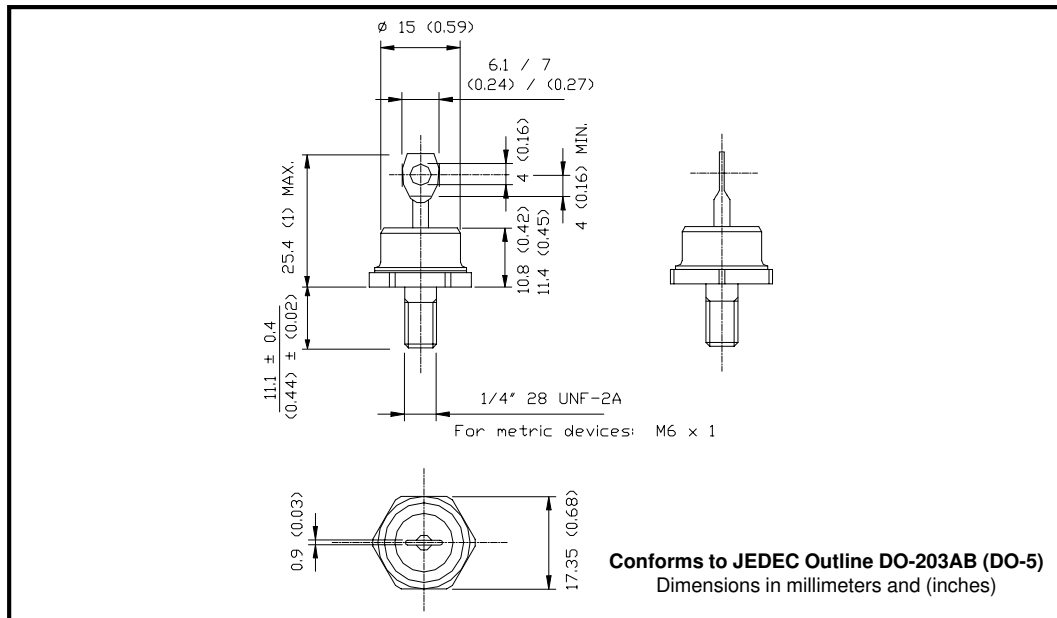

Voltage Ratings

Part number	1N6392
V_R Max. DC Reverse Voltage (V)	45*
V_{RWM} Max. Working Peak Reverse Voltage (V)	

Absolute Maximum Ratings

Parameters	1N6392	Units	Conditions
$I_{F(AV)}$ Max. Average Forward Current See Fig. 5	60*	A	50% duty cycle @ $T_C = 115^\circ\text{C}$, rectangular wave form
	54*		50% duty cycle @ $T_C = 115^\circ\text{C}$, sinusoidal wave form
I_{FSM} Max. Peak One Cycle Non-Repetitive Surge Current See Fig. 7	9000	A	5 μs Sine or 3 μs Rect. pulse. Following any rated load condition and with rated V_{RWM} applied
	1000*		60Hz half cycle sine wave or 5ms rectangular pulse
E_{AS} Non-Repetitive Avalanche Energy	101	mJ	$T_J = 25^\circ\text{C}$, $I_{AS} = 15$ Amps, $L = 0.9$ mH
I_{AR} Repetitive Avalanche Current	15	A	Current decaying linearly to zero in 1 μsec Frequency limited by T_J max. $V_A = 1.5 \times V_R$ typical

Electrical Specifications

Parameters	1N6392	Units	Conditions
V_{FM} Max. Forward Voltage Drop (1) See Fig. 1	0.47*	V	@ 10A
	0.68*	V	@ 60A
	0.82*	V	@ 120A
	0.59*	V	@ 10A
I_{RM} Max. Reverse Leakage Current (1) See Fig. 2	20*	mA	$T_J = 25^\circ\text{C}$
	60*	mA	$T_J = 125^\circ\text{C}$
	600*	mA	$T_J = 175^\circ\text{C}$
C_T Max. Junction Capacitance	3000	pF	$V_R = 5V_{DC}$, (test signal range 100Khz to 1Mhz) 25°C
L_S Typical Series Inductance	7.5	nH	Measured from top of terminal to mounting plane
dv/dt Max. Voltage Rate of Change	10000	V/ μs	(Rated V_R)

(1) Pulse Width < 300 μs , Duty Cycle < 2%

Thermal-Mechanical Specifications

Parameters	1N6392	Units	Conditions
T_J Max. Junction Temperature Range	-55 to 175*	$^\circ\text{C}$	
T_{stg} Max. Storage Temperature Range	-55 to 175*	$^\circ\text{C}$	
R_{thJC} Max. Thermal Resistance Junction to Case	1.0*	$^\circ\text{C}/\text{W}$	DC operation See Fig. 4
R_{thCS} Typical Thermal Resistance, Case to Heatsink	0.25*	$^\circ\text{C}/\text{W}$	Mounting surface, smooth and greased
R_{thCA} Max. Thermal Resistance, Case to Ambient	7.0*	$^\circ\text{C}/\text{W}$	R_{thCA} is the value for which device blocking stability with rated V_R or V_{RWM} applied assured, when $T_A = 25^\circ\text{C}$ and $T_C = 148^\circ\text{C}$ (DC) or $T_C = 163^\circ\text{C}$ (AC operation)
wt Approximate Weight	15.6(0.55)	g(oz.)	
T Mounting Torque	Min.	2.26(20)	N-m (lbf-in)
	Max.	3.39(30)	
Case Style	DO-203AB(DO-5)		JEDEC

* JEDEC Registered Values

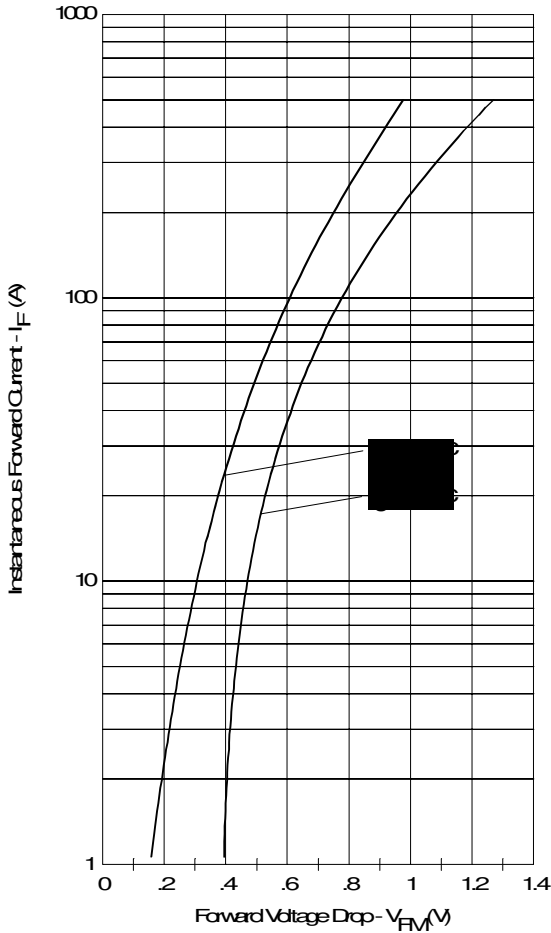

Fig. 1 - Maximum Forward Voltage Drop Characteristics

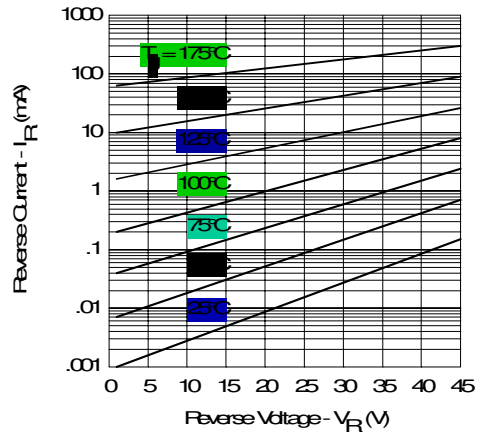

Fig. 2 - Typical Values of Reverse Current Vs. Reverse Voltage

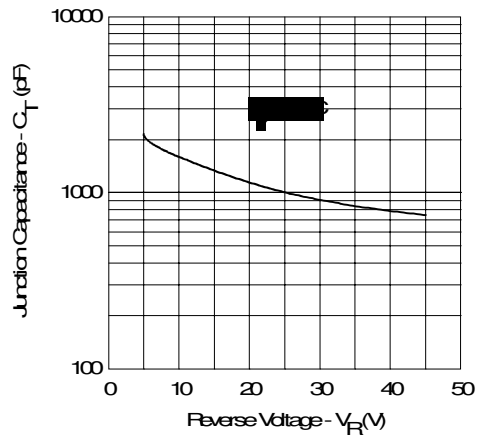

Fig. 3 - Typical Junction Capacitance Vs. Reverse Voltage

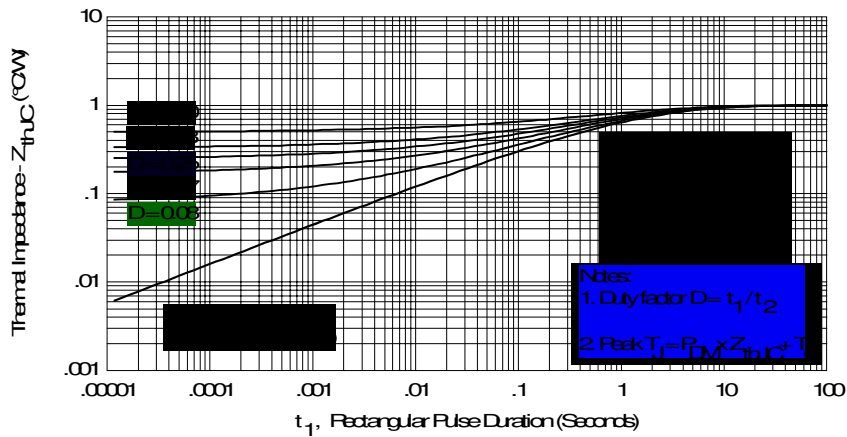

Fig. 4 - Maximum Thermal Impedance Z_{thJC} Characteristics

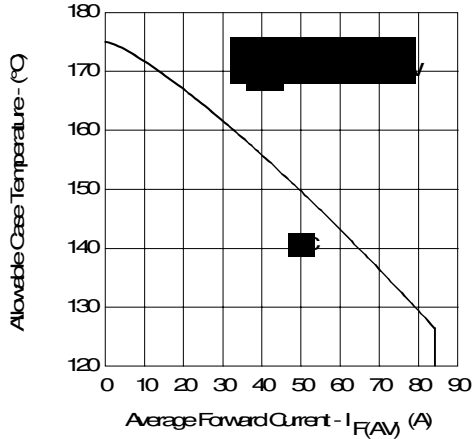

Fig. 5 - Maximum Allowable Case Temperature Vs. Average Forward Current

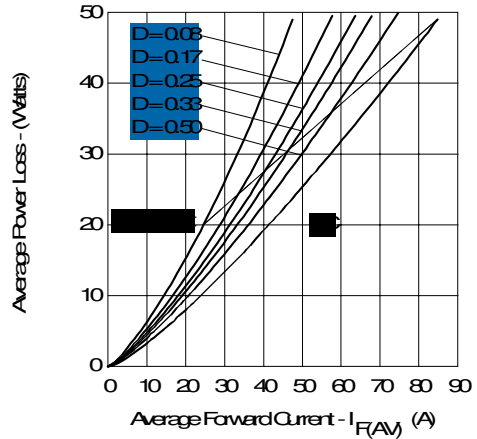

Fig. 6 - Forward Power Loss Characteristics

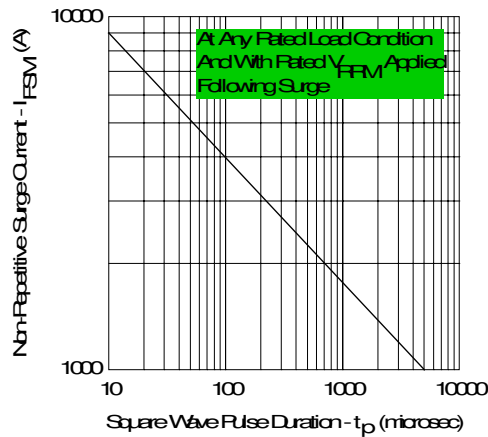

Fig. 7 - Maximum Non-Repetitive Surge Current

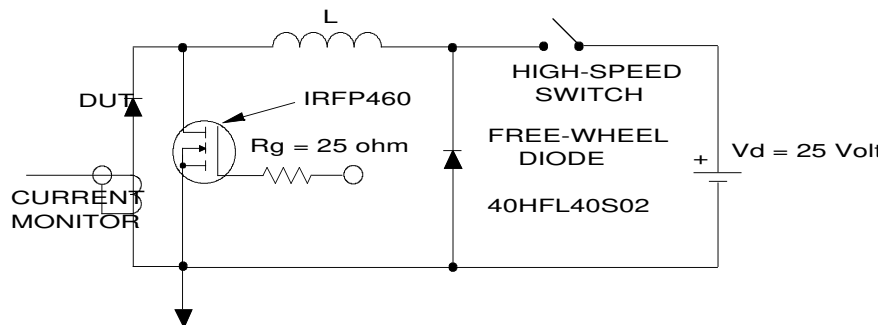

Fig. 8 - Unclamped Inductive Test Circuit

Data and specifications subject to change without notice.
This product has been designed for Industrial Level.
Qualification Standards can be found on IR's Web site.

International
IOR Rectifier

IR WORLD HEADQUARTERS: 233 Kansas St., El Segundo, California 90245, USA Tel: (310) 252-7105
TAC Fax: (310) 252-7309
Visit us at www.irf.com for sales contact information. 11/02