

FEATURES

Complete 900 MHz RF Transceiver

LNA

Receive Mixer

Transmit Mixer

Driver Amplifier

VCO

Prescaler

Limiter Amplifier with RSSI

On-Chip Low Dropout Regulator

Independent Sleep Modes for TX, RX

28-Lead SSOP Package

APPLICATIONS

902 MHz–928 MHz ISM Band Cordless Telephones

902 MHz–928 MHz ISM Band Wireless Data Systems

GENERAL DESCRIPTION

The AD6190 900 MHz RF Transceiver provides a complete RF/IF section for systems operating in the 902 MHz–928 MHz license-free ISM band. The high level of integration allows several dozen discrete components to be replaced. It is ideally suited for use in cordless telephone and wireless data applications.

The receiver section includes a Low Noise Amplifier (LNA). The LNA's output drives an image-reject mixer; the mixer's output optimized for 10.7 MHz is filtered and processed by the limiting IF amplifier.

The transmit section accepts a modulated 10.7 MHz IF input, and uses an image-reject upconverter to mix the signal up to the 902 MHz–928 MHz RF carrier frequency while suppressing the unwanted image and LO components. The RF output is raised to a nominal 0.5 milliwatt (–3 dBm) output level. This output can be used directly or can drive an external power amplifier to higher levels.

The on-chip VCO operates at 2× the local oscillator frequency. This reduces oscillator pulling due to strong interferers in-band or transmitter leakage. An on-chip 64/65 prescaler allows the VCO to be controlled by a low cost 15 MHz CMOS synthesizer.

An on-chip low dropout regulator minimizes VCO pushing. The transmit section, receive section, or both, can be placed in a low current SLEEP mode when not in use. The AD6190 900 MHz RF transceiver is packaged in a 28-lead SSOP package.

The AD6190 900 MHz RF Transceiver is part of the Analog Devices/Zilog “A-to-Z Phone” Spread-Spectrum System for cordless telephone and data communications applications. Contact Zilog directly at (408) 370-8000 for more information on the Z87000 series baseband controller chips.

FUNCTIONAL BLOCK DIAGRAM

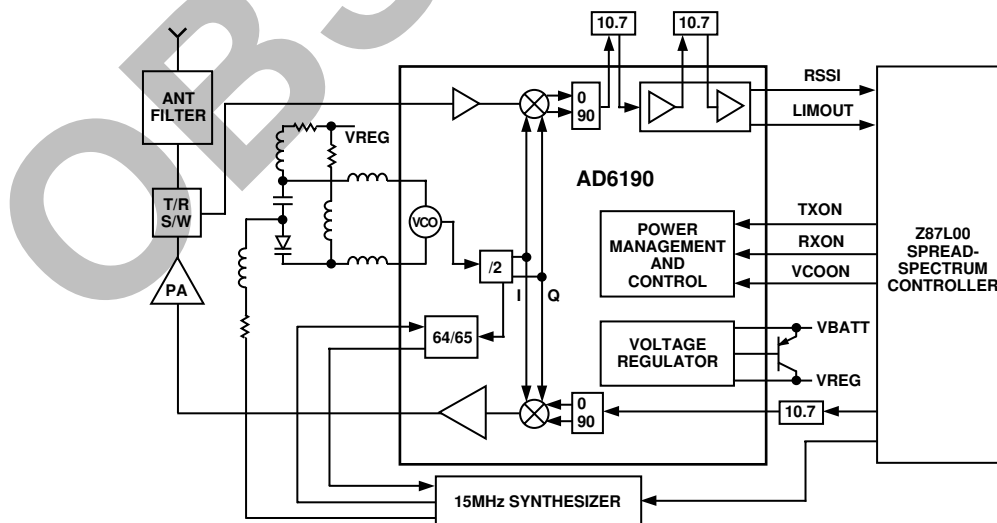

REV. 0

Information furnished by Analog Devices is believed to be accurate and reliable. However, no responsibility is assumed by Analog Devices for its use, nor for any infringements of patents or other rights of third parties which may result from its use. No license is granted by implication or otherwise under any patent or patent rights of Analog Devices.

AD6190–SPECIFICATIONS (@ T_A = +25°C, V_{CC} = +3.3 V, F_{IF} = 10.7 MHz, F_{RF} = 902 MHz–928 MHz, TX IF Input level 137 mV p-p, unless otherwise noted)

Parameter	Conditions	Min	Typ	Max	Units
RECEIVE RF SECTION					
(LNA to Mixer Output)	Source Z = 50 Ω, IF Load Z = 330 Ω				
Power Gain			24		dB
Noise Figure			4.2		dB
1 dB Compression (Input)			-30		dBm
Input IP3			-17		dBm
Image Rejection	F _{RF} = 915 MHz, F _{LO} = 904.3 MHz	28	33		dBc
TRANSMIT UPCONVERTER					
Image Rejection	F _{IF} = 10.7 MHz, F _{LO} = 904.3 MHz	35	48		dBc
LO Feedthrough	F _{IF} = 10.7 MHz, F _{LO} = 904.3 MHz		-33		dBm
DRIVER AMPLIFIER					
Nominal Output Power	For IF Input Level = 137 mV p-p		-3		dBm
1 dB Compression		0	+4.5		dBm
VCO					
Operating Frequency	(LO Frequency ×2)	1783		1835	MHz
PRESCALER					
Division Ratio					
PREMOD = "1"			64		
PREMOD = "0"			65		
Output Level	R _L = 2.2 k, C _L < 10 pF	0.55	1.0		V p-p
IF LIMITER AMPLIFIER					
First Stage Gain			24		dB
Second Stage Gain			70		dB
AC Output Level	R _L > 30 kΩ, C _L < 30 pF		450		mV p-p
DC Level			1.76		V
IF Port Impedance	F _{IF} = 10.7 MHz		330		Ω
RSSI OUTPUT					
Slope	With 10 Ω in Series with VCCIF		22		mV/dB
Output Voltage	@ -100 dBm RF Input		0.90		V
	@ -30 dBm RF Input		2.40		V
Linear Range	(With Respect to RF Input Level)		70		dB
RSSI Log Conformance Error			±2		dB
SUPPLY CURRENT					
	(VCC = 3.3 V)				
Transmit Mode	TXON, VCOON = 1; RXON = 0		93		mA
Receive Mode	RXON, VCOON = 1; TXON = 0		59		mA
Sleep Mode	TXON, VCOON, RXON = 0		270		μA
SUPPLY VOLTAGE					
VBATT		3.0		4.6	V
Other Supplies	VCCTX, VCCIF, VCCLNA	3.0	3.3	3.6	V
VCO REGULATOR					
Output Voltage	Output Voltage, 3.0 < VBATT < 4.6 V	2.65		2.85	V
TEMPERATURE RANGE					
		-20		+85	°C

Specifications subject to change without notice.

ABSOLUTE MAXIMUM RATINGS¹

Supply Voltage

VBATT, VCCIF, LNAVCC, VCCTX to GND+5.5 V
 Maximum RF Input Level Without Damage +20 dBm
 Internal Power Dissipation² 500 mW
 Operating Temperature Range -25°C to +85°C
 Storage Temperature Range -65°C to +150°C
 Lead Temperature Range
 (Soldering, 60 sec) +300°C

NOTES

¹Stresses above those listed under Absolute Maximum Ratings may cause permanent damage to the device. This is a stress rating only; functional operation of the device at these or any other conditions above those indicated in the operational section of this specification is not implied. Exposure to absolute maximum rating conditions for extended periods may affect device reliability.

²Thermal Characteristics: 28-lead SSOP package $\theta_{JA} = 122^{\circ}\text{C/W}$.

ORDERING GUIDE

Model	Package Description	Package Option
AD6190ARS	28-Lead Shrink Small Outline	RS-28
AD6190ARSRL	28-Lead Shrink Small Outline, Supplied on Reels, 1500 Units per Reel	

Minimum order quantity 25,000 units.

CAUTION

ESD (electrostatic discharge) sensitive device. Electrostatic charges as high as 4000 V readily accumulate on the human body and test equipment and can discharge without detection. Although the AD6190 features proprietary ESD protection circuitry, permanent damage may occur on devices subjected to high energy electrostatic discharges. Therefore, proper ESD precautions are recommended to avoid performance degradation or loss of functionality.

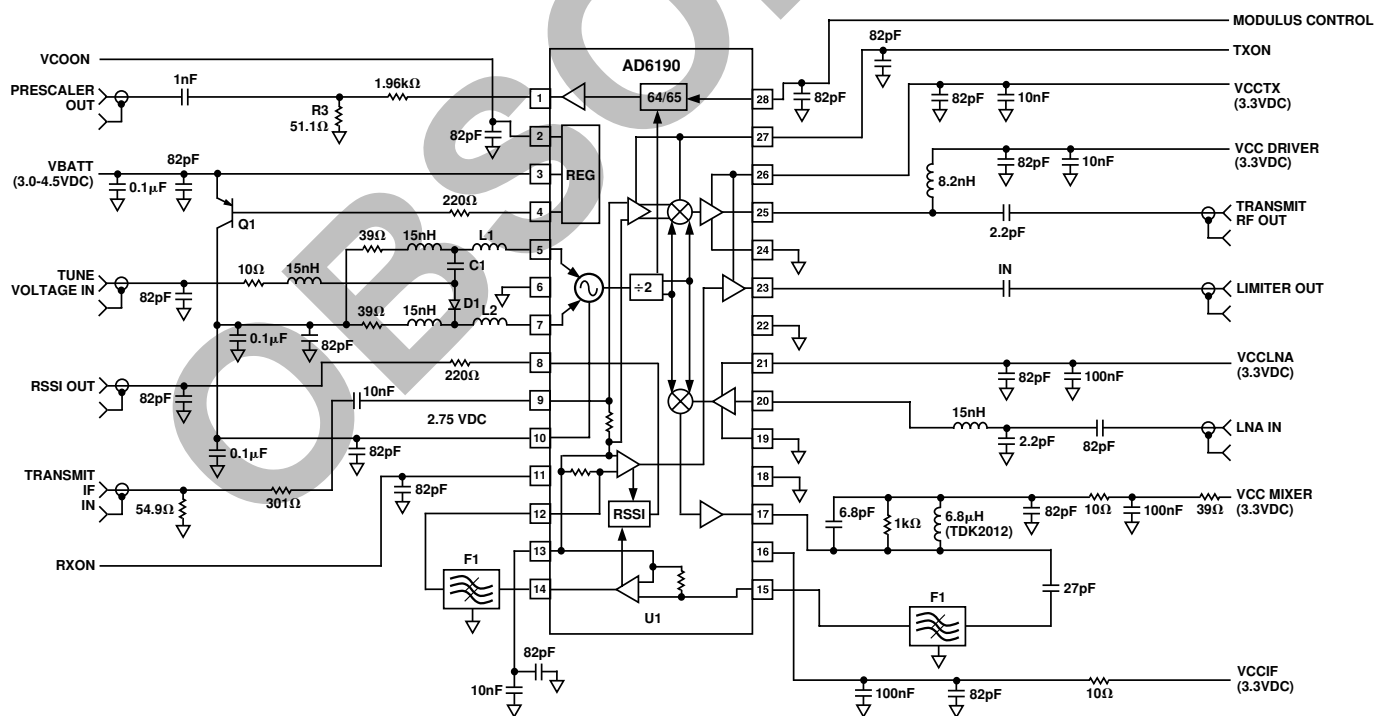
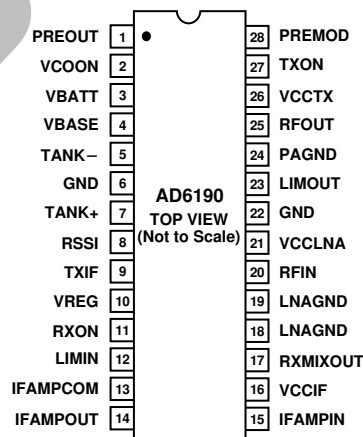

Figure 1. Test Circuit

PIN FUNCTION DESCRIPTIONS

No.	Pin Name	Type	Function/Description
1	PREOUT	Output	Prescaler Output. Usually connected to input of external low frequency CMOS synthesizer (Fujitsu MB87006A, Siemens PMB2307, or similar).
2	VCOON	Control	Logic "1" turns on power to VCO, and divider/prescalers.
3	VBATT	Power	VBATT connection for regulator. Normally connected to 3.3 V dc or battery.
4	VBASE	Power	Base connection to external regulator pass transistor (MMBT3906 or similar).
5	TANK-	Input	Connection for VCO tank circuit (LC network).
6	GND	Power	Substrate ground connection.
7	TANK+	Input	Connection for VCO tank circuit (LC network).
8	RSSI	Output	Received Signal Strength Indicator output signal.
9	TXIF	Input	Accepts modulated transmit signal at 10.7 MHz IF.
10	VREG	Power	Regulated VCC for LO from external pass transistor.
11	RXON	Control	Logic "1" turns on power to LNA and receive mixer stages.
12	LIMIN	Input	Input to limiting amplifier.
13	IFAMPCOM	Input	Input signal common for limiting amplifier.
14	IFAMPOUT	Output	Output of first stage of IF amplifier. Normally connected through 10.7 MHz filter to Pin 12 (LIMIN).
15	IFAMPIN	Input	Input to first stage of IF amplifier.
16	VCCIF	Power	Local VCC connection for IF amp/limiter stages.
17	RXMIXOUT	Output	10.7 MHz IF Output. Normally connected through 10.7 MHz filter to IF amplifier input (Pin 15).
18	LNAGND	Power	Local ground for LNA.
19	GND	Power	Substrate ground connection.
20	RFIN	Input	LNA Input. Normally driven single-ended from 50 Ω source impedance.
21	VCCLNA	Power	VCC for LNA.
22	GND	Power	Substrate ground connection.
23	LIMOUT	Output	10.7 MHz limiter output.
24	PAGND	Power	Local ground for PA stage emitter. Degeneration may be added.
25	RFOUT	Output	Transmitted RF output signal at 0 dBm level.
26	VCCTX	Power	Local VCC connection for TX stages.
27	TXON	Control	Logic "1" turns on power to transmit mixer, buffers, and PA stages.
28	PREMOD	Input	Prescaler Modulus control (HIGH = divide-by-64; LOW = divide-by-65).

PIN CONFIGURATION



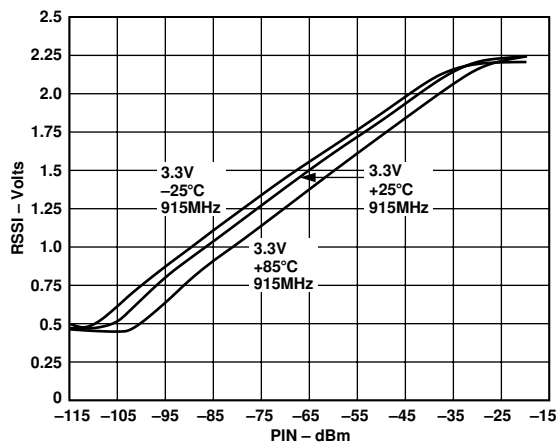

Figure 2. RSSI Voltage vs. Input Power

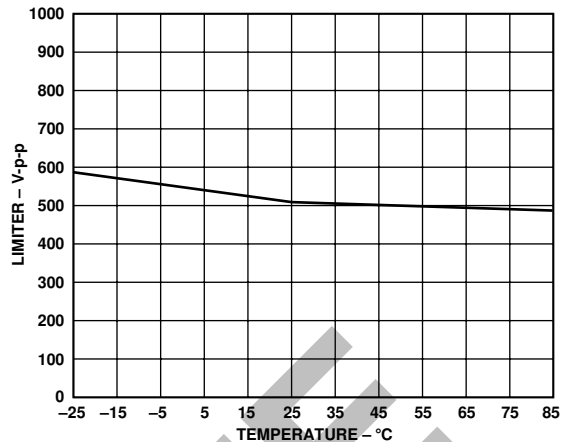

Figure 5. Limiter Output Level vs. Temperature @ 3.3 V and 915 MHz

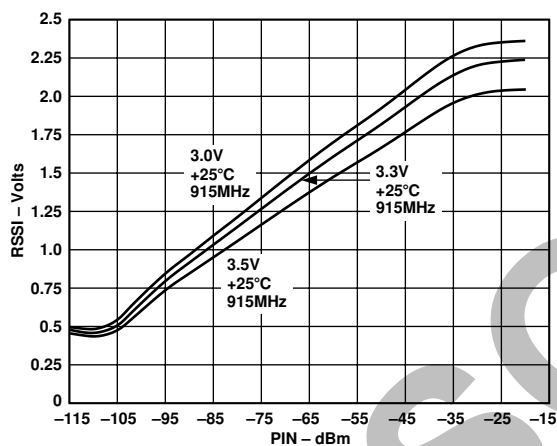

Figure 3. RSSI Voltage vs. Input Power

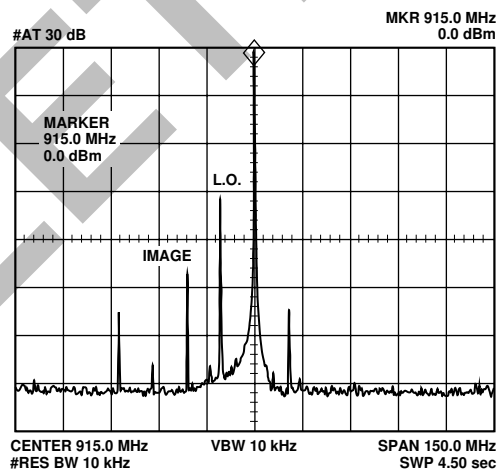

Figure 6. Frequency Spectrum

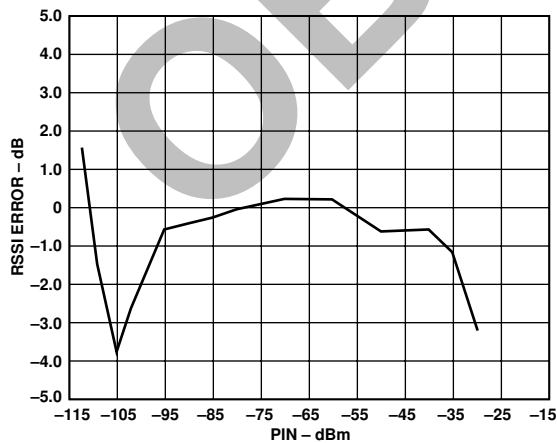

Figure 4. RSSI Error vs. Input Power

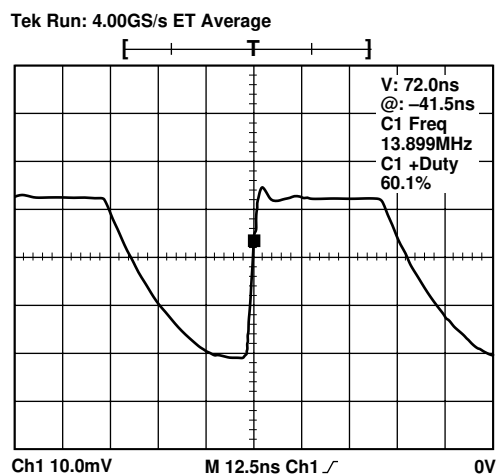

Figure 7. Prescaler Output

AD6190

PRODUCT DESCRIPTION

The AD6190 is a complete RF/IF transceiver for operation in the 902 MHz–928 MHz Industrial, Scientific and Medical (“ISM”) frequency band. Together with a suitable spread-spectrum controller, the AD6190 can be used to design a spread-spectrum system compliant with FCC “Part 15” (47CFR15.247) regulations. The AD6190 is a fully compatible companion chip to the Zilog Z87L00 “ZPhone” frequency-hopping spread-spectrum controller.

The AD6190 includes a receive path of LNA, image-reject mixer, IF amplifier and limiter amplifier with RSSI. The transmit path accepts a 10.7 MHz IF input signal, and uses image-reject upconversion to the 902 MHz–928 MHz band. Frequency control is achieved using an on-chip VCO and dual-modulus prescaler connected to an inexpensive low frequency PLL for channel selection and frequency hopping.

Additionally, an on-chip voltage regulator stabilizes the VCO to prevent LO pushing due to power supply variations.

APPLYING THE AD6190

Receive Signal Path

The AD6190 Low Noise Amplifier (LNA) and image-reject mixer together provide downconverter with a total gain of 24 dB and a typical Noise Figure (NF) of 4.2 dB.

The LNA input port exhibits an impedance of $320-j61$ at 915 MHz. In order to provide an optimum match to a 50 Ω source, the network shown in Figure 8 should be used.

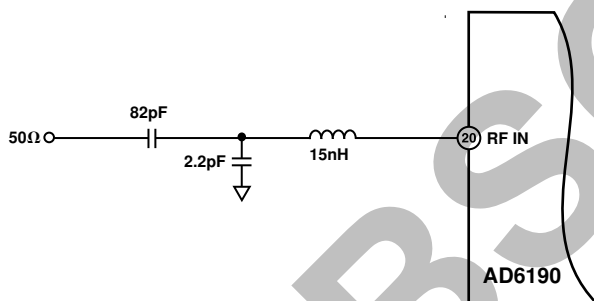

Figure 8. LNA Input Matching Circuit

The frequency plan of the AD6190 provides the lowest possible RF implementation cost. A single conversion design is used with a 10.7 MHz IF to take advantage of the very low cost filters available. However, since the 902 MHz–928 MHz band is wider than twice the IF, it is possible that undesired in-band signals will be mixed down to the IF. These images could cause interference to the desired signal. It is thus necessary to provide tunable filtering before the receive mixer, or some other approach to eliminate interference from image signals.

In the AD6190, a technique known as “image-reject” (or SSB) mixing is used. This technique suppresses image interference by using a pair of mixers with quadrature local oscillators. See Figure 9.

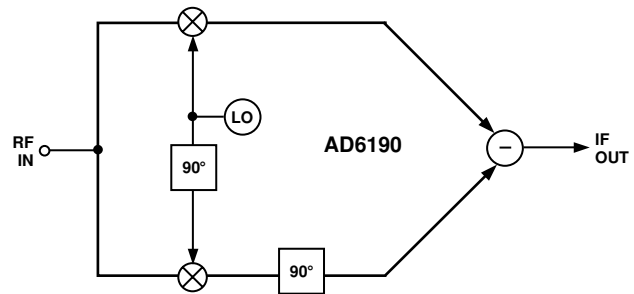

Figure 9. Image-Reject Mixer

The RF signal, containing both the desired signal at $(F_{LO} + F_{IF})$ and another possible signal at the image frequency of $(F_{LO} - F_{IF})$ is applied to two mixers in parallel. These mixers are driven by local oscillator signals in quadrature. The mixer outputs at the two mixer IF ports contain both the desired signal and the image signal. However, the outputs of the two mixers are in quadrature (shifted 90 degrees relative to each other). The outputs of the two mixers are then shifted another 90 degrees relative to each other in a phase-shift network. The two mixer outputs thus contain the desired signal and the image signal exactly 180 degrees out of phase. By adding (or subtracting) the two signals, the undesired image signals cancel, the desired signal components add, and image-rejection occurs. Local oscillator leakage is suppressed by the use of doubly-balanced mixers.

The quality of the image rejection is a function of the phase and amplitude matching of the quadrature branches of the LO and IF phase-shift networks. In the AD6190, image-rejection is typically 33 dB.

The mixer output that drives the input side of the first 10.7 MHz filter should also be connected through a parallel RLC network of 6.8 pF, 1 k Ω , and 7 pF to the power supply to match the 330 Ω filter impedance.

The 10.7 MHz IF signal is then filtered and amplified by a 24 dB fixed gain. The output of this stage is further filtered, and applied to a 6-stage limiting amplifier. The limiter output signal is typically 450 mV p-p into a 30 k Ω , 30 pF load, with a dc offset level of approximately 1.76 V dc.

All 10.7 MHz IF filters are assumed to be standard 330 Ω impedance ceramic types. The AD6190 RX IF signal chain and TX IF input includes internal matching resistors for this impedance.

When used with the Zilog Z87L00 Spread-Spectrum Controller IC, the 10.7 MHz IF signal contains the received data encoded in FSK modulation with approximately a ± 33 kHz deviation. The Z87L00 performs the FSK demodulation in the digital domain.

The RSSI (Received Signal Strength Indicator) signal represents the strength of the received signal, linear in dB, and scales with supply voltage. With a 3.3 V supply (through a 10 Ω resistor on the VCCIF pin), an RF signal level of -100 dBm at the LNA input will produce an RSSI voltage of approximately 900 mV. The RSSI voltage will increase with increasing RF input level, at approximately 22 mV/dB to approximately 2.4 V at -30 dBm input. The RSSI output voltage remains above 2.4 V for input levels up to +15 dBm.

Transmit Signal Path

The AD6190 transmit chain is designed to accept an input signal generated by the Z87L00 device. The Z87L00 provides a digitally-generated FSK signal at 2.508 MHz, sampled at 8.192 MSPS. This sampling process produces a signal with components at 2.508 MHz, 5.684 MHz, 10.7 MHz, 16.386 MHz, and other higher-order image products at frequencies of $(N \times 8.192 \text{ MHz} \pm 2.508) \text{ MHz}$. This signal is filtered to select the 10.7 MHz image, which is used as the transmit IF signal for the AD6190.

An image-reject transmit up-converts the 10.7 MHz IF signal to the 902 MHz–928 MHz RF band, with image and spurious outputs typically 45 dB below the desired signal, and LO leakage typically –33 dBc.

The on-chip driver can provide at least 1 mW (0 dBm) into a 50 Ω load. However, when driving an external Power Amplifier (PA) with a gain of 15 dB or more, we recommend a nominal driver output power no higher than –3 dBm (137 mV p-p TX input level) to avoid spurious PA output products in excess of FCC allowances. The RFOUT pin is normally connected through an 8.2 nH dc feed inductor, and ac-coupled to the power amplifier.

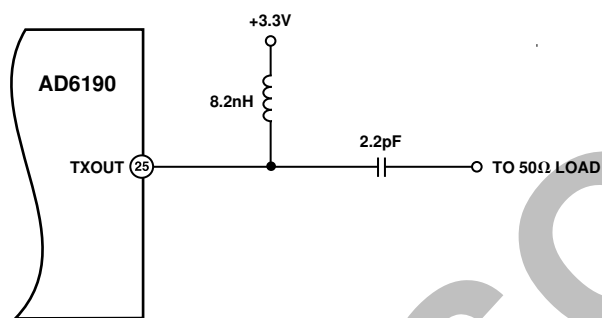

Figure 10. TXOUT Matching Circuit

Frequency Control

The AD6190 includes an on-chip voltage controlled oscillator for LO generation. An external varactor-tuned tank circuit controls the frequency. This VCO operates at twice the required LO frequency for several reasons.

First, it is a simple matter to generate the I and Q LO components needed for the image-reject mixers by starting with a LO at twice the desired frequency. The divide-by-two process can easily provide coarse quadrature signals. Any remaining phase error is further reduced by an on-chip connection network.

Second, by keeping the oscillator operating at a frequency far removed from the RF carrier frequency, parasitic feedback from either the transmit signal or strong received signals is minimized. This reduces VCO “pulling” effects.

A typical series resonant VCO tank circuit is shown in Figure 11. The oscillator actually operates at twice the required LO frequency band. The tank inductors (L1, L2) may be implemented as printed traces on the PC board or as lumped circuit chip components. The printed lines are implemented in nonmicrostrip to produce higher Q. At least two foil layers should be removed immediately under the tank area. A suitable tank structure can be formed from two parallel lines, each approximately 7 mm long by 0.3 mm wide, continuing out from the device pads. In

other words, the Pin 5 and Pin 7 pads are simply extended to form L1 and L2. Equivalent Hi-Q chip inductors in the 2.2 nH to 4.7 nH range may be substituted.

The single tuning varactor, D1, (e.g., Alpha Industries SMV-1233-011) and a fixed capacitor C1 (or a common anode dual diode) are located on the ends of the lines. Note that this is a positive supply (VREG) referenced “pump-down” tank, meaning that as the TUNE voltage is increased toward VREG, the frequency goes down. The loop filter return should also be referenced to VREG (not ground) in order to minimize common-mode noise pickup and frequency pushing. The designer is cautioned to develop a tank with only as much kVCO as required to allow easy coverage of the band with respect to component tolerance and production issues, in order to minimize phase noise and frequency pulling.

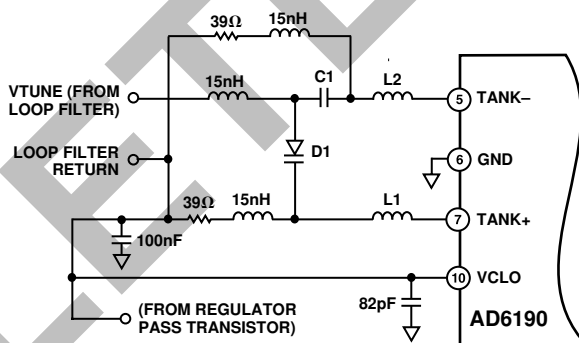

Figure 11. Typical VCO Tank Circuit

An on-chip dual-modulus (64/65) prescaler allows the frequency control to be done with a low-cost low-frequency PLL synthesizer chip, such as the Fujitsu MB87006A, Siemens PMB2307, or similar.

The prescaler output should be connected to ground through a 2.2 k Ω pull-down resistor. The output signal (typically 1 V p-p) is sufficient to drive most low cost PLLs, and is usually ac-coupled through a 1 nF capacitor to the PLL input.

Layout, Grounding and Decoupling

The AD6190 is a complex device with high bandwidth and high gain on-chip. Proper layout, grounding and decoupling, techniques are essential to realizing the full performance of the system. Each of the power supply pins should be decoupled to ground at the chip using a 82 pF chip capacitor in parallel with a 10 nF chip capacitor. The VCCIF pin requires a 10 Ω series resistor in addition to the 82 pF shunt capacitor.

Voltage Regulator

The AD6190 includes an on-chip voltage regulator to stabilize the supply voltage for the local oscillator, isolating it from any variations or noise on the main power supply voltage in the system. This regulator is nominally set for 2.75 V output. An external PNP pass transistor provides the needed output current for the VCO.

This regulator is intended to stabilize the voltage for the LO only, and should not be used for other circuitry. VBATT may be connected to a 3.3 V dc preregulator or to the preconditioned three-cell battery system.

AD6190

Mode Controls

The AD6190 is designed as a time-division-duplex (TDD) radio. This means that the transmitter and receiver operate at different times. The AD6190 includes control pins to shut down unused portions of the circuit when not needed, saving power, as shown in the table below. For any mode except "Sleep," power must be applied to VBATT Pin 3 and to all VCC Pins (16, 21 and 26) to ensure proper operation.

NOTE: Do not enable both the transmit and receive paths simultaneously.

Table I.

Mode	RXON	TXON	VCOON	Notes
Receive	1	0	1	Allows VCO/PLL to settle prior to transmit time slot.
Transmit	0	1	1	
"Sleep"	0	0	0	
VCO Only	0	0	1	

OUTLINE DIMENSIONS

Dimensions shown in inches and (mm).

28-Lead Shrink Small Outline (RS-28)

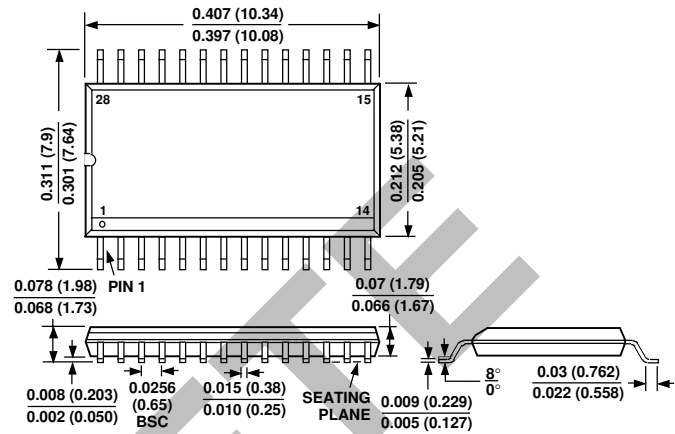

C3231-8-1/98

OBSOLETE

PRINTED IN U.S.A.