



PRODUCT OVERVIEW

The D2U5T-H3-5000-380-HU3C is a High Efficiency 3500/5000 watt, power factor corrected three phase power supply for 230/480Vac lines with a 380V high voltage (HVDC) main output and a selectable 5V or 3.3V (20W) standby. The unit is provided with Droop Sharing and up to three (3) power modules may be operated in parallel.

The power module is hot pluggable. The module is able to protect and recover from over temperature faults, and has status LEDs on the front panel and additional logic and PMBus status signals.

Their 2U package and >16.5W/cubic inch power density make them ideal for delivering reliable, efficient power to servers, workstations, storage systems and other 380V HVDC distributed power systems. An optional power shelf is also available that accommodates up to three (3) power modules.

FEATURES

- 5KW (480Vac), 3.5KW (230Vac) Output Power
- Very High Efficiency; 95.4% @ 50% FL
- 380V High Voltage Main Output
- 3.3V or 5V Standby Output
- Nominal Dim's: 5.1"(W) x 18"(L) x 3.3" (2U)
- 16.5 watts/cubic inch power density
- N+1 redundant (including hot docking)
- Droop sharing on Main Output
- Over-voltage, over-current, over-temperature protections
- Internal cooling fan
- I2C Bus Interface with status indicators
- Optional 19" power shelf
- RoHS compliant
- Two-year warranty

ORDERING GUIDE

Model Number	Power	Main Output	Standby Output	Airflow
D2U5T-H3-5000-380-HU3C	5000W	380V	3.3V or 5V (Selectable)	Front to Back

INPUT CHARACTERISTICS

Parameter	Conditions	Min	Typ	Max	Units
Input Frequency		47	50/60	63	Hz
Input Voltage Operating Range	Range 1	180		264	Vac
	Range 2	320		528	Vac
Turn-on Voltage (Ramp-up)	Range 1		170		Vac
	Range 2		280		Vac
Turn-off Voltage (Ramp-down)	Range 1		150		Vac
	Range 2		260		Vac
Maximum Input Current			13		Arms
Inrush Current	Cold Start			30	Apk
Power Factor, Range 1, 60Hz	600W, 230 Vac		0.992		
	1750W (50%), 230 Vac		0.998		
	3500W (100%), 230 Vac		0.998		
Power Factor, Range 2, 60Hz	600W, 480 Vac		0.910		
	2500W (50%), 480 Vac		0.995		
	5000W (100%), 480 Vac		0.995		

OVERALL CHARACTERISTICS

Parameter	Conditions	Min	Typ	Max	Units
Output Power	Range 1			3500	W
	Range 2			5000	
Efficiency, Range 1	700W (20%), 230Vac		89.5		%
	1750W (50%), 230Vac		93.6		
	3500W (100%), 230Vac		94.2		
Efficiency, Range 2	500W (20%), 230Vac		92.6		%
	2500W (50%), 230Vac		95.4		
	5000W (100%), 230Vac		95.4		

The following curves represent the achieved efficiency performance for the D2U5T-H3-5000-380-HU3C product compared against a recognized industry standard for efficiency rating.

The D2U5T-H3-5000-380-HU3C offers performance in excess of the industry standard limit as a required percentage of loading.

Test methodology as per Ecova Generalized Test Protocol for Calculating the Energy Efficiency of Internal AC-DC and DC-DC Power Supplies Revision 6.7



Available now at:

www.murata-ps.com/en/3d/acdc.html



EFFICIENCY PERFORMANCE CURVES

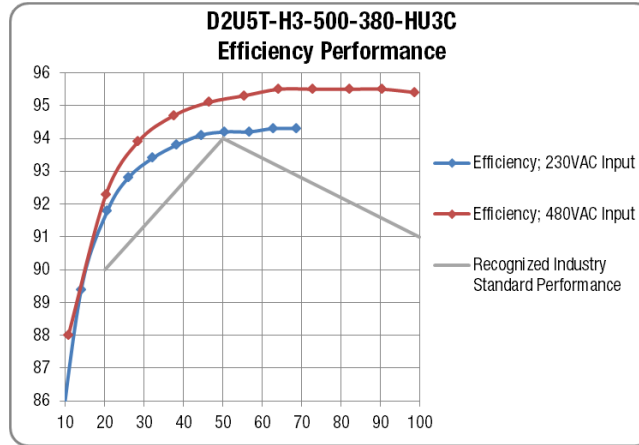

OUTPUT VOLTAGE CHARACTERISTICS

Output	Parameter	Conditions	Min	Typ	Max	Units
380V	Output Current	Range 1	0		9.2	A
		Range 2	0		13.34	
	Voltage Set Point	@4.6A Range 1		380		Vdc
		@6.67A Range 2		380		
	Voltage Droop	Min to Max Current, Range 1			7	%
		Min to Max Current, Range 2			11	
Line Regulation				0.1	%	
Ripple Voltage & Noise ¹				1	Vp-p	
Load Capacitance			100		1000	μF
3.3VSB	Voltage Set Point			3.3		Vdc
	Line and Load Regulation		3.14		3.46	%
	Ripple Voltage & Noise ²	20MHz Bandwidth			75	mVp-p
	Output Current		0		6	A
Load Capacitance			20		1000	μF
5VSB	Voltage Set Point			5		Vdc
	Line and Load Regulation		4.76		5.24	%
	Ripple Voltage & Noise ²	20MHz Bandwidth			100	mVp-p
	Output Current		0		4	A
	Load Capacitance			20		1000

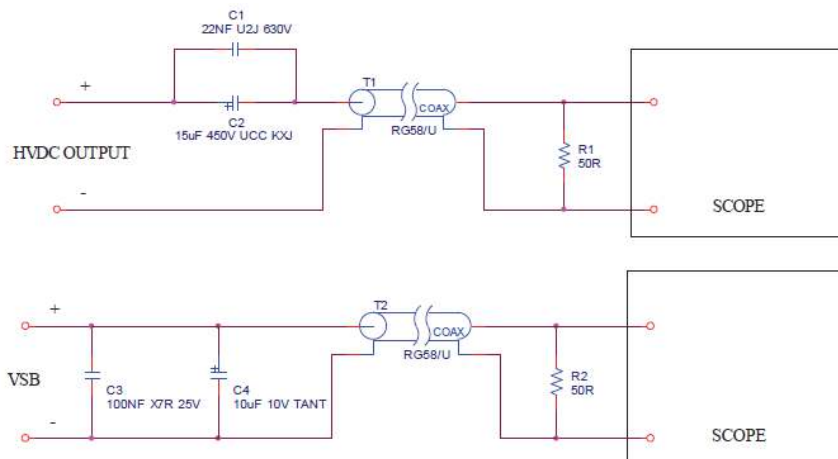

¹ Ripple and noise are measured with 22nF (U2J 630V) ceramic + 15 μF (UCC KXJ) of electrolytic de-coupling capacitors at the output connector load side. A short coaxial cable with 50ohm scope termination is used.

² Ripple and noise are measured with 0.1 μF of ceramic capacitance and 10 μF of tantalum capacitance across the power supply outputs at the output connector load side. A short coaxial cable with 50ohm scope termination is used.

OUTPUT CHARACTERISTICS

Parameter	Conditions	Min	Typ	Max	Units
Startup Time	AC ramp up			3	s
Transient Response	380V, 50-100% load step, 0.1A/μs di/dt		15		Vp-p
	5VSB, 50-100% load step, 1A/μs di/dt		250		mVp-p
	3.3VSB, 50-100% load step, 1A/μs di/dt		165		mVp-p
Current sharing accuracy (up to 3 in parallel)	380V @100% load			+/-10	%
Hot Swap Transients	All outputs within regulation				
Holdup Time	380V @100% load	25			ms
	VSB @100% Load	500			

GENERAL CHARACTERISTICS

Parameter	Conditions	Min	Typ	Max	Units
Storage Temperature Range		-40		70	°C
Operating Temperature Range		-15		50	°C
Operating Humidity	Non-condensing	10		90	%
Storage Humidity	Non-condensing	5		90	%
Altitude	(Without derating at 40°C)		3000		m
	(Without derating at 50°C)		1800		
Shock	30G non-operating				
Sinusoidal Vibration	0.5G, 5 – 500 Hz				
MTBF	Calculated per Telcordia SR-332 @40°C	220K			hrs
Weight			7		kg
Safety Approvals	CAN/CSA C22.2 No 60950-1-07, Am.1:2011, Am 2:2014 ANSI/UL 60950-1-2014 IEC60950-1:2005 (2nd Ed.), Am 1:2009 + Am 2:2013 EN 60950-1:2006+A11:2009 +A1:2010 +A12:2011 +A2:2013				
Input Fuses	Power Supply has one internal 16A/500V fast blow fuse on each of the three AC line inputs.				
Material Flammability	UL 94V0				

PROTECTION CHARACTERISTICS

Output	Parameter	Conditions	Min	Typ	Max	Units
380V	Over-temperature (intake)	Auto-restart	57	60	63	°C
	Over Voltage	Latching	418		445	V
	Over Current Range 1	Hiccup or Latching	105		130	%
	Over Current Range 2	Hiccup or Latching	105		130	%
3.3VSB	Over Voltage	Latching	3.9		4.3	V
	Over Current	Hiccup	6.3		9	A
5VSB	Over Voltage	Latching	5.6		6.0	V
	Over Current	Hiccup	4.2		6	A

EMISSIONS AND IMMUNITY		
Characteristic	Standard	Compliance
Input Current Harmonics	IEC/EN 61000-3-2	Complies
Conducted Emissions	FCC 47 CFR Parts 15	Class A, 6dB margin
Radiated Emissions (in the application)	CISPR 22 EN55022	Class A, 6dB margin
ESD Immunity	IEC/EN 61000-4-2	Level 3 criteria A
Radiated Field Immunity	IEC/EN 61000-4-3	Level 3 criteria B
Electrical Fast Transients/Burst Immunity	IEC/EN 61000-4-4	Level 3 criteria A
Surge Immunity	IEC/EN 61000-4-5	Level 3 criteria A
RF Conducted Immunity	IEC/EN 61000-4-6	Level 3 criteria A
Magnetic Field Immunity	IEC/EN 61000-4-8	3 A/m criteria B
Voltage Dips & Interruptions	IEC/EN 61000-4-11	400Vrms Input Voltage Main & VSB Outputs, Performance a) 100% load, Phase 0°, Dip 100% Duration 10ms 50% load, Phase 0°, Dip 100% Duration 20ms Main & VSB Outputs, Performance b) 100% load, Phase 0°, Dip 100% Duration >10ms Any Load, Phase 0°, Dip 100% Duration >100ms
Voltage imbalance (Circuit will stop when input voltage imbalance exceeds 8% for more than 100ms. Unit will restart when imbalance returns below 8%)		Any valid Input Voltage, any load Main & VSB Outputs, Performance a) Dip 30% on single Phase or Line, Duration 100ms Main & VSB Outputs, Performance b) Dip 30% on single Phase or Line, Duration >100ms

ISOLATION CHARACTERISTICS					
Parameter	Conditions	Min	Typ	Max	Units
Insulation Safety Rating/Test Voltage	Input to Output – Reinforced	3000			Vrms
	Input to Chassis – Basic	1500			Vrms
	Output to Chassis – Basic	1150			Vrms



STATUS INDICATORS (LEDs)			
Status Indicators	Input OK (Green)	Output OK (Green)	Fault ⁴ (Yellow)
AC input voltage is not present	Off	Off	Off
AC present and within the required operational range Standby – ON; Main Output – OFF (disabled)	Solid Green	Blinking	Off
AC present, but its level is not within the required operational range	Blinking Green at 1Hz rate (0.5s on, 0.5s off)	Off	Off
When hot-unplugging the power supply from a power shelf ³	Blinking Green at 1Hz rate (0.5s on, 0.5s off)	Off	Off
AC present and within the required operational range Standby – ON and within the specified regulation range Main Output – ON and within the specified regulation range	Solid Green	Solid Green	Off
AC present and within the required operational range Standby – ON and within the specified regulation range Main Output – ON and within the specified regulation range Main output overcurrent condition are indicated depending upon severity and application of overload and specific detection mechanism responding:			
Output power warning Pout overpower fault Iout overcurrent fault	Solid Green Solid Green Solid Green	Solid Green Solid Green Blinking Green	Blinking 1Hz On On
Any warning Levels (Input UV/OV, OC, Inlet Temp, Output and STBY OV/UV, OC, OTP, FAN)	No Change	No Change	Blinking 1Hz
Any Fault Levels (Input UV/OV, OC, Inlet Temp, Output and STBY OV/UV, OC, OTP, FAN)	Depends on PS	Depends on PS Status	Depends on PS Status

³ The Input OK LED blinks to indicate that there is still energy inside the power supply until the input bulk capacitors are completely discharged or the housekeeping circuit is shut down.

⁴ The Fault LED and PS Fault signal shall be turned on to indicate that there is one or more of the following internal faults currently detected inside the power supply:

- VSB out of range
- Output stage OT
- Fan fault
- ORING fault (Output voltage less than bus voltage)
- OC shutdown
- OT shutdown
- OV shutdown
- Input stage OT
- Fault induced shutdown occurred
- Thermal sensor fault
- Vout out of range
- PFC Boost Vbulk fault

As soon as all of the above faults are removed and the power supply operates normally, the Fault LED and PS Fault signal shall be turned off. LED Definition: Three LEDs shall be located on the front faceplate; these are:

LED	Status
	Input OK = ON
	Output OK = ON
	Fault = ON

CONTROL SIGNALS					
Signal (I/O)	Description				
PS_ON_H	Internal 10K pull-up resistor to internal VDD. ⁵ <ul style="list-style-type: none"> ■ Leaving signal pin open = Main Output ON ■ Tying signal pin to GND = Main Output OFF 				
PS_KILL	Short pin; internal 10K pull-up resistor to internal VDD. ⁵ <ul style="list-style-type: none"> ■ Leaving signal pin open = All Outputs off ■ Tying signal pin to GND = All Outputs enabled 				
PS_PRESENT	Internally shorted to SIG_GND, STBY_RTN <ul style="list-style-type: none"> ■ used by system (where signal may be pulled up) for detection of a power module being installed into backplane. 				
PS_FAULT_L	Internal 10K pull-up resistor to internal VDD ⁵ <ul style="list-style-type: none"> ■ PSU Fault Status 				
PWR_GOOD_H	Internal 10K pull-up resistor to internal VDD. ⁵ <ul style="list-style-type: none"> ■ Main Output Status OK 				
STBY_SEL_IN	Internal 10K pull-up resistor to internal VDD ⁵ <ul style="list-style-type: none"> ■ Leaving signal pin open = +5VSTBY ■ Tying signal pin to GND = +3V3STBY 				
AC_OK_H	Internal 10K pull-up resistor to internal VDD. ⁵ <ul style="list-style-type: none"> ■ AC OK Status 				
SMB_ALERT_L	Internal 10K pull-up resistor to internal VDD ⁵ <ul style="list-style-type: none"> ■ SMB Alert signal output 				
VOUT_PRE-CHARGE, +/-	Input to Power Module for hotswap function. <ul style="list-style-type: none"> ■ + VOUT_PRE_CHARGE: internally pulled up via 1K OHM resistor to main output return “+“ ■ - VOUT_PRE_CHARGE: internally pulled up via 1K OHM resistor to main output return “-“ 				
A0, A1 & A2	Addressing bit lines used can be used to assign the power supply's controller and EEPROM device PMBus address. The table below lists the possible address combinations that can be assigned.				
DEVICE ADDRESS PIN STRAPPING ADDRESS OPTIONS					
Serial Address Bits			Corresponding Power Module Slave Device Address		
A2 Bit 2	A1 Bit 1	A0 Bit 0	PSU Main Controller (Secondary)	PSU EEPROM (External)	
LOW	LOW	LOW	0xB0	0xA0	
LOW	LOW	HIGH	0xB2	0xA2	
LOW	HIGH	LOW	0xB4	0xA4	
LOW	HIGH	HIGH	0xB6	0xA6	
HIGH	LOW	LOW	0xB8	0xA8	
HIGH	LOW	HIGH	0xBA	0xAA	
HIGH	HIGH	LOW	0xBC	0xAC	
HIGH	HIGH	HIGH	0xBE	0xAE	
<ul style="list-style-type: none"> ■ Each address line is pulled up via 10K to internal VDD ■ All three (3) pins unterminated result in address BE and AE respectively 					
Refer to Application notes ACAN-61 and ACAN-63 for further details					

⁵VDD depends on Standby Voltage selection of either 3.3V or 5V.

OUTPUT CONNECTOR & PIN ASSIGNMENT (Power Module Connector: FCI Power Blade Part # 51915-424 (MATING CONNECTOR: FCI 51939-826LF)

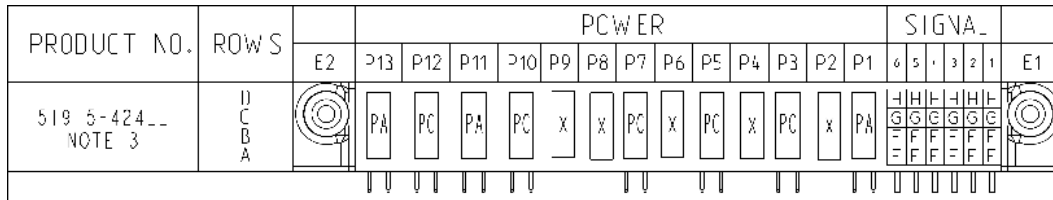

Pin	Designation	Function	Signal Direction	Pin	Designation	Function	Signal Direction
P13	-VOUT_PRE-CHARGE	Hot Swap Pre Charge	Output	B1	A2	I2C Address Bit 2 Signal	Input
P12	-VOUT	380Vdc return	Output	B2	PS_ON_H	Enable PSU	Input
P11	+VOUT_PRE-CHARGE	Hot Swap Pre Charge	Output	B3	+VSB	+3.3V/5V STBY Out	Output
P10	+VOUT	380Vdc	Output	B4	SDA	I2C Data Signal	Bi-Directional
P9	Not fitted	-	-	B5	PS_KILL	Enable PSU	Input
P8	Not fitted	-	-	B6	VSB_RTN	VSTBY_RT	Output
P7	AC1	AC Line Voltage Ph 1	Input	C1	STBY_SEL_IN	Selects +3V3 or +5VSTBY	Input
P6	Not fitted	-	-	C2	AC_OK_H	AC(DC) OK Status	Output
P5	AC2	AC Line Voltage Ph 2	Input	C3	+VSB	+3.3V/5V STBY Out	Output
P4	Not fitted	-	-	C4	+VSB	+3.3V/5V STBY Out	Output
P3	AC3	AC Line Voltage Ph 3	Input	C5	VSB_RTN	VSTBY_RT	Output
P2	Not fitted	-	-	C6	VSB_RTN	VSTBY_RT	Output
P1	GND	Safety ground	Input	D1	SMB_ALERT_L	SMB Alert signal output	Output
A1	A1	I2C Address Bit 1 Signal	Input	D2	PWR_GOOD_H	Power OK Status	Output
A2	PS_FAULT_L	PSU Fault Status	Output	D3	+VSB	+3.3V/5V STBY Out	Output
A3	A0	I2C Address Bit 0 Signal	Input	D4	+VSB	+3.3V/5V STBY Out	Output
A4	PS_PRESENT	PSU Seated into Connector	Output	D5	VSB_RTN	VSTBY_RT	Output
A5	SCL	I2C Clock Signal	Bi-Directional	D6	VSB_RTN	VSTBY_RT	Output
A6	SGND	Signal ground (return)	Output				

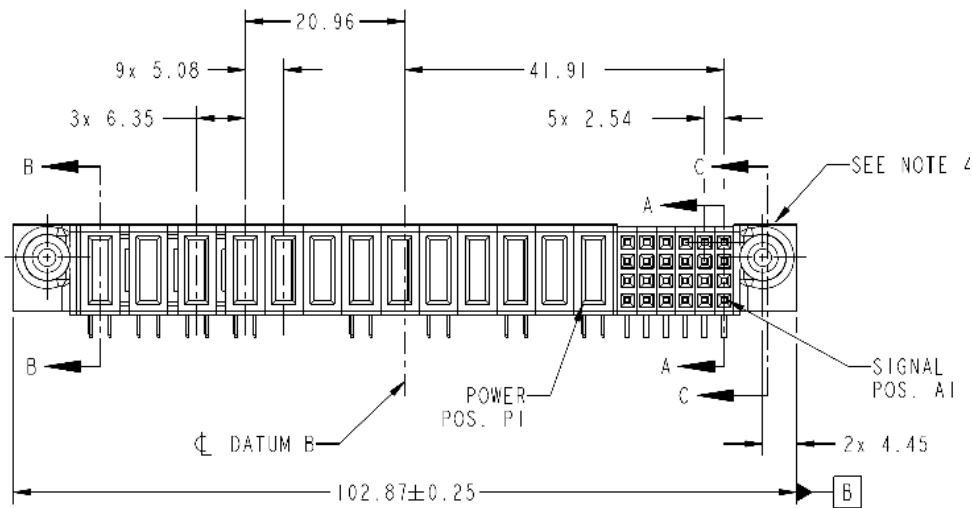

MECHANICAL DIMENSIONS

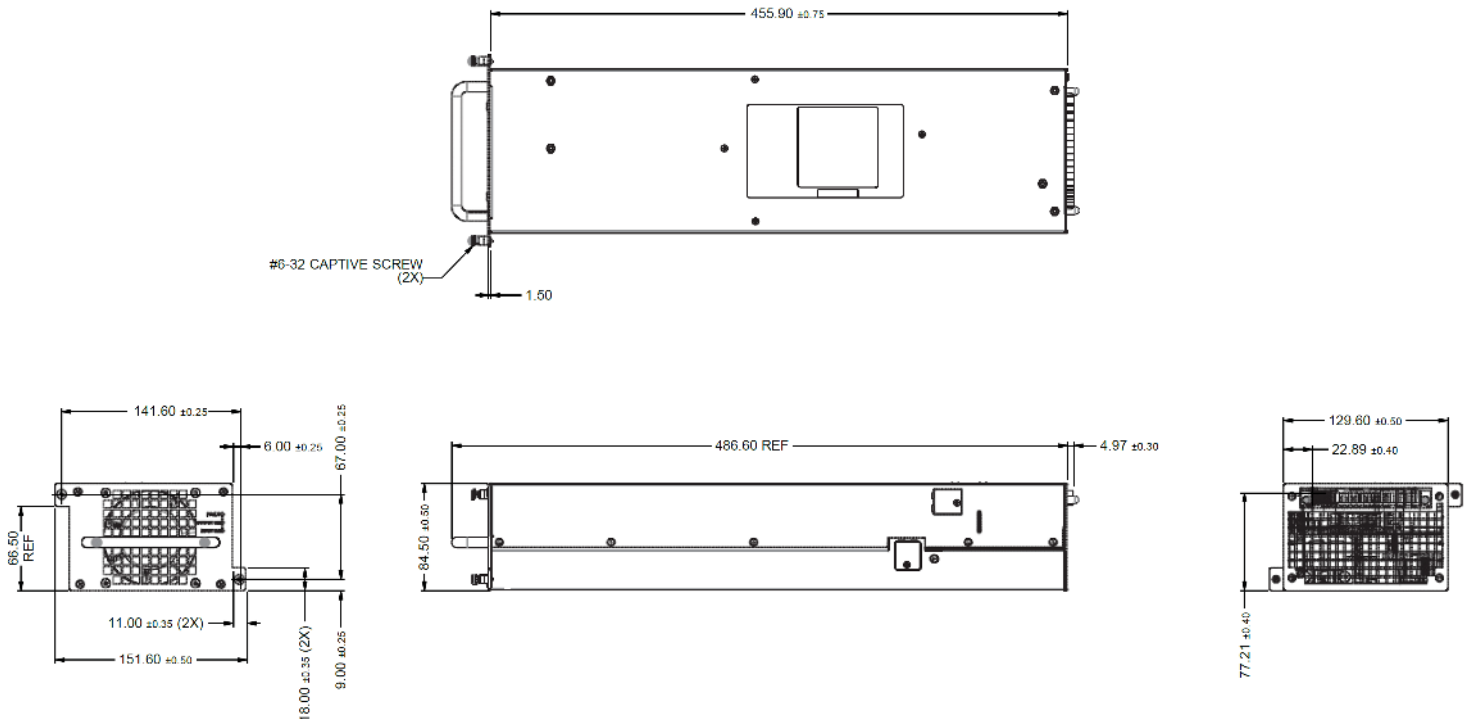

Dimensions: 5.1" x 18" x 3.3" [129.5mm x 455.9mm x 84.5mm]

NOTES:

- 1) THE DRAWING IS ONLY FOR MECHANICAL DIMENSIONS;
- 2) THE DRAWING IS A GRAPHIC REPRESENTATION OF THE REAL PRODUCT. THE PATTERNS OF FEATURE MAY NOT SHOW ALL FINE DETAILS OR CORRECT PATTERNS. FOR EXAMPLES, THE SCREW FACE PATTERNS OR FAN PATTERNS OR CONNECTOR (ETC) MAY LOOK DIFFERENT THAN REAL PART.

OPTIONAL ACCESSORIES

Description	Part Number
12V D2U5T-380 Output Connector Card	D2U5T-380-CONC

APPLICATION NOTES

Document Number	Description	Link
ACAN-62	D2U5T-380-CONC Customer Interface Connector Card	http://power.murata.com/datasheet/?/data/apnotes/acan-62.pdf
ACAN-63	PMBus™ Communication Protocol for: D2U5T-H3-5000-380-Hu3C	http://power.murata.com/datasheet/?/data/apnotes/acan-63.pdf

Murata Power Solutions, Inc.
129 Flanders Road
Westborough, MA 01581
ISO 9001 and 14001 REGISTERED



This product is subject to the following operating requirements and the Life and Safety Critical Application Sales Policy. Refer to: <http://www.murata-ps.com/requirements/>

Murata Power Solutions, Inc. ("Murata") makes no representation that the use of its products in the circuits described herein, or the use of other technical information contained herein, will not infringe upon existing or future patent rights. The descriptions contained herein do not imply the granting of licenses to make, use, or sell equipment constructed in accordance therewith. Buyer represents and agrees that it has all the necessary expertise to create and implement safeguards that anticipate dangerous consequences of failures, monitor failures and their consequences, lessen the likelihood of failures that might cause harm, and take appropriate remedial actions. Buyer will fully indemnify Murata, its affiliated companies, and its representatives against any damages arising out of the use of any Murata products in safety-critical applications. Specifications are subject to change without notice.

© 2018 Murata Power Solutions, Inc.