

MOD-BT

Bluetooth UEXT module

User's Manual



All boards produced by Olimex are ROHS compliant

Rev. C, July 2016

Copyright(c) 2010, OLIMEX Ltd, All rights reserved

INTRODUCTION

MOD-BT is development board with female UEXT connector, which can be connected directly to Olimex boards that have male UEXT connector can work as bluetooth serial port via RS232.

BOARD FEATURES

- BGB203HS06 – combines the Bluetooth RF part, protocol stack, Link Controller (LC), Link Manager (LM), and Host Controller Interface (HCI) firmware of the Bluetooth system specification in one SiP with embedded software. Together with an antenna and a reference clock this device forms a complete Bluetooth solution. Note that the chip comes with SPP firmware described in the stack documentation.
- UEXT female connector
- On-board antenna
- Three types of power supply – 1.8V, 2.8V and 3.3V
- PCB: FR-4, 1.5 mm (0.062"), red soldermask, white silkscreen component print
- Dimensions: (35.9 x 18.8)mm ~ (1.41 x 0.74)"

ELECTROSTATIC WARNING

The MOD-BT board is shipped in protective anti-static packaging. The board must not be subject to high electrostatic potentials. General practice for working with static sensitive devices should be applied when working with this board.

BOARD USE REQUIREMENTS

Hardware: one of our development boards with male UEXT connector.

BLUETOOTH CONTROLLER HARDWARE FEATURES

MOD-BT board use BGB203HS06 bluetooth system-in-a-package radio with baseband controller and SPP firmware with these features:

- General
 - Plug-and-play Bluetooth class 1 System-in-a-Package (SiP)
 - Includes all baseband and radio functionality, from HCI up to antenna, needs only external antenna and reference clock.
 - Fully compliant to Bluetooth Radio Specification version 1.2.
- Radio hardware
 - Fully integrated near-zero-IF receiver with high sensitivity (typical -88 dBm at antenna input)
 - Digital demodulator for improved reception quality
 - RSSI with high dynamic range
 - Programmable output pre-amplifier
 - Maximum output power up to +5.5 dBm typical
 - Includes high performance blocking filter for co-existence in GSM/DCS/WCDMA applications
 - Fully integrated low phase noise VCO operating in the 5 GHz frequency range
- Hardware features
 - Bluetooth burst mode controller with:
 - Ciphering, scrambling, CRC checking/generation, FEC encoding/decoding and data buffering control
 - Support for 7 slaves and three piconets, support of master-slave switch for new nodes entering the piconet, scatternet support with maximum one slave in master piconet while being slave in another piconet, support for 2 voice channels.
 - BT1.2 features:
 - Fast connection
 - EV3 (HV3+CRC)
 - AFH IP: AFH switch support as master, Channel assessment as master
 - Embedded 32-bit microprocessor consisting of
 - An ARM7TDMI-S RISC controller featuring low mW/MHz
 - Integrated Flash memory : 268 kBytes.
 - SRAM : 40 kBytes.

- Voice processing with
 - A CVSD, A-law or m-law.
 - Support of a direct link between PCM interface and BT1.2 core for the voice channels.
- Power management providing
 - Power-on reset
- Clocking
 - Low power clock crystal oscillator for low power mode, accepting 3.2KHz, 32KHz, and 32.768KHz.
 - Low-power system clock crystal oscillator with programmable on-chip capacitors for frequency adjustment with large pulling range accepting the frequency 12MHz, 13MHz, 24MHz and 26 MHz.
- Microprocessor interfaces
 - General purpose I/O-pins
 - I²C-bus interface
 - Multi port PCM interface (linear and log PCM up to 16 bit/sample supported)
 - UART with hardware handshake and IrDA support
 - USB interface (vddio2 : 3.3V).
 - System timers
 - Watch dog timer
 - JTAG for ICE and flash memory programming
 - ETM7 for real time trace.
 - Patch interface for ROM version emulation.
- Voltage range
 - Radio 2.75 V
 - Core 1.8 V
 - Peripheral pins 1.8 and 3.3V

FIRMWARE FEATURES

This section provides an overview of the features provided by the SPP Module firmware. More detail on the features may be found in "BGB203_SPP_UserGuide.pdf".

Command Interface

- Subset of V.25
- Extensions following the GSM command convention
- Configurable via command interface
- Configurable escape sequence

Physical Interface

- Universal Asynchronous Receive Transmit (UART)
- Configurable UART
 - Baud rate
 - Word length
 - Parity
 - Stop bits
 - RTS/CTS flow control
 - DTR/DSR flow control
- RS-232 signal support
 - Support for CD, RI, DTR/DSR (including pass-through)
 - Support for DCE or DTE device
- Active connection output

Bluetooth Features

- Supports Bluetooth 1.2 features of BGB203
 - Fast connection
 - Adaptive Frequency Hopping (AFH)
- Entirely embedded Bluetooth protocol stack
 - Link Controller (LC)
 - Link Manager (LM)
 - Logical Link and Adaptation Protocol (L2CAP)
 - Service Discovery Protocol (SDP)
 - RFCOMM Protocol (RFCOMM)
 - Serial Port Profile (SPP)
 - Generic Access Profile (GAP)

Bluetooth Functionality

- Inquiry
- Service Discovery with filter
- Remote Name discovery
- Link Key management
- Pairing (active and passive)
- Serial Port Profile server
- Configurable service name
- Configurable access control
- Serial Port Profile client
- Configurable RFCOMM port
- Configurable connection attempts
- Configurable local device discoverability
- Configurable local device name
- Configurable local class of device
- Configurable link supervision timeout
- Configurable PIN codes
- Configurable Security and/or Encryption
- Configurable sniff low power mode
- Master/slave role switch supported

Test Modes

- Bluetooth test mode
- FCC/Bluetooth transmission test modes
- Calibration mode (RXTUN)

Miscellaneous Features

- Configuration storable to Flash
- Automatic re-connect mode
- Low power sleep mode

BLOCK DIAGRAM

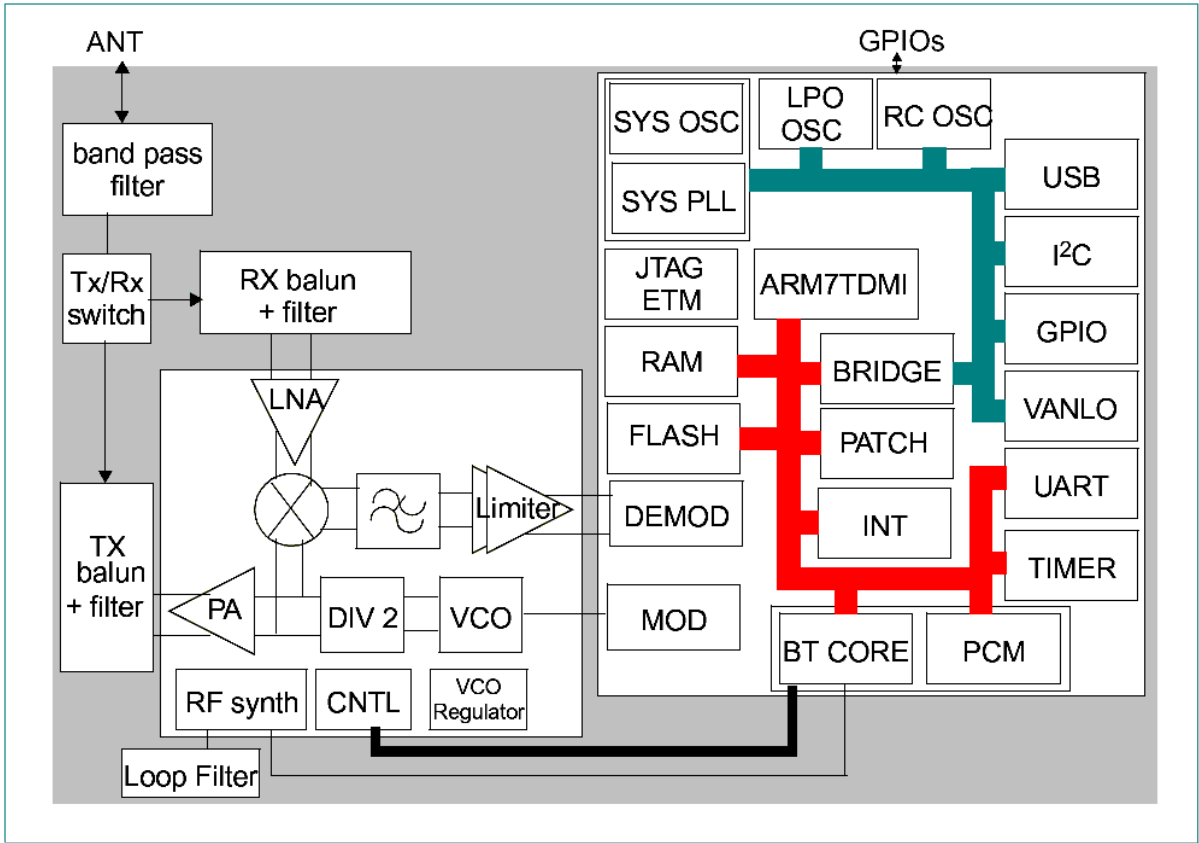

SCHEMATIC

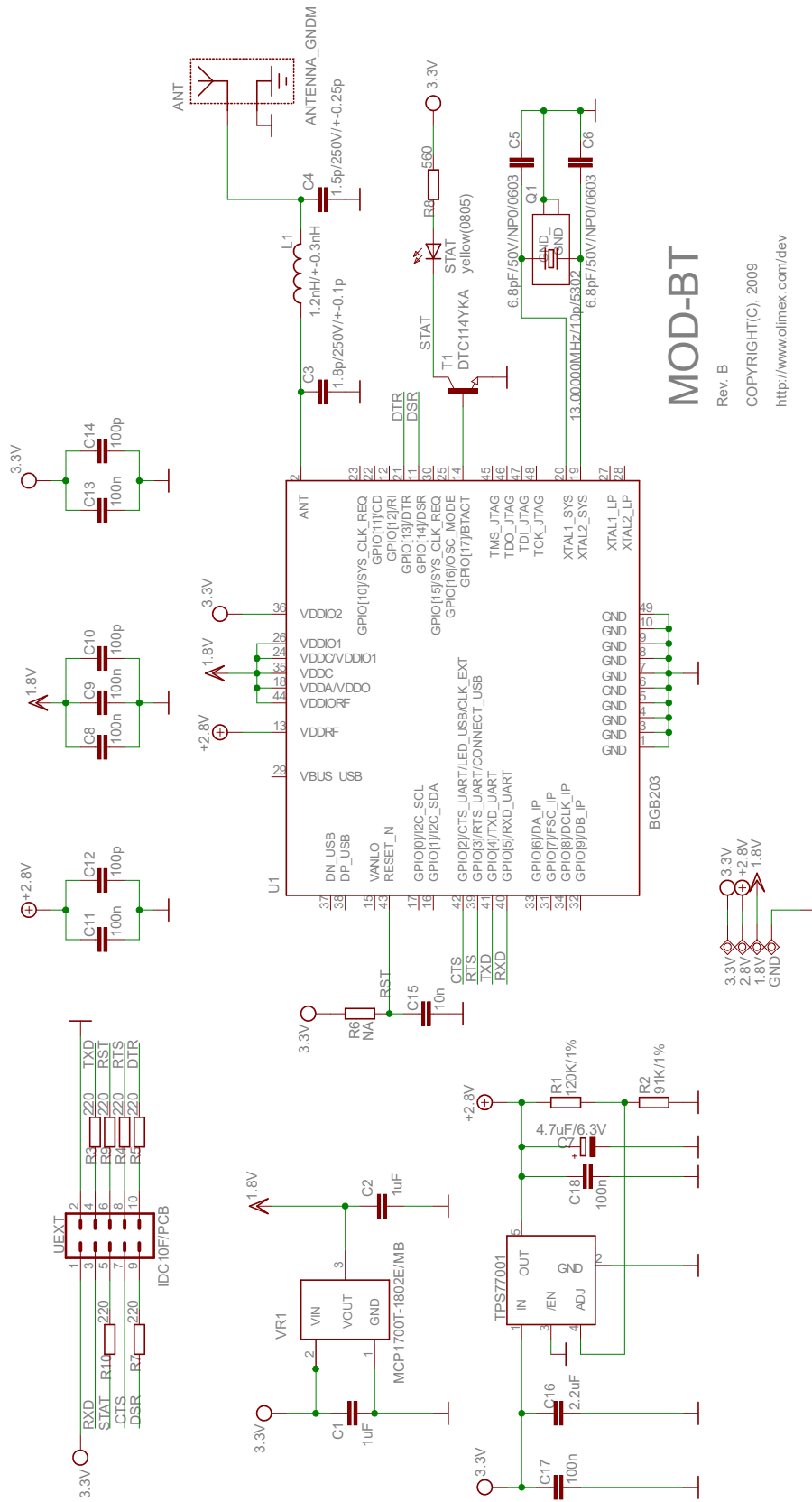

MOD-BT

Rev. B
 COPYR(GHT(C), 2009
<http://www.olimex.com/dev>

BOARD LAYOUT

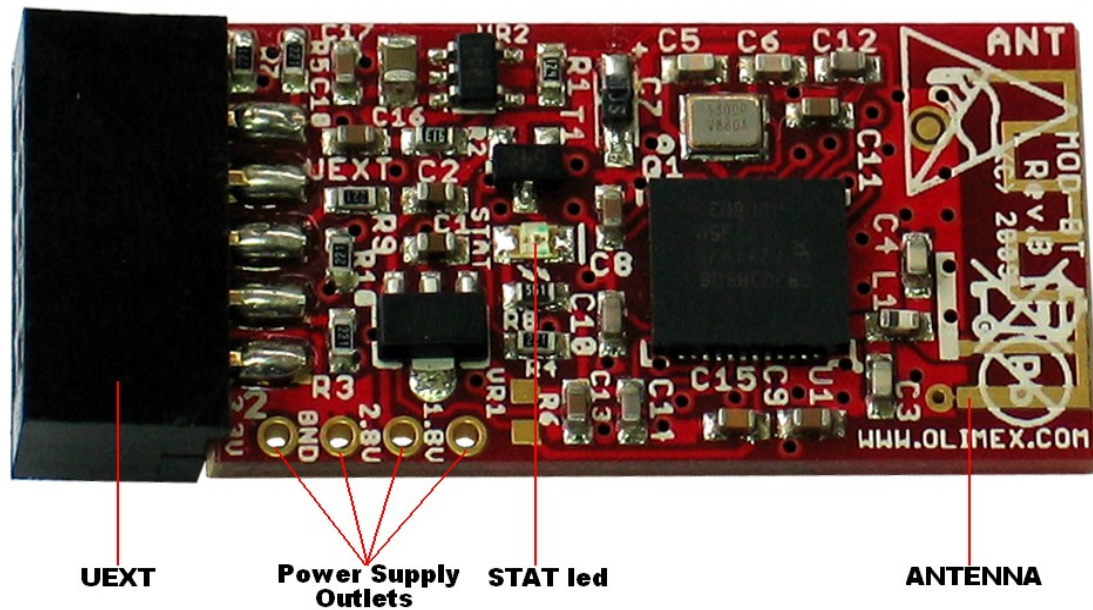

POWER SUPPLY CIRCUIT

MOD-BT is typically power supplied by UEXT pin 1 and pin 2 with 3.3V.

There are two more power supplies – 2.8V for Radio and 1.8V for the core.

RESET CIRCUIT

MOD-BT reset circuit includes pin 6 of UEXT connector, pin 43 (RESET_N) of U1 and C15 (10nF).

CLOCK CIRCUIT

Quartz crystal 13 MHz is connected to BGB203 pin 20 (XTAL1_SYS) and pin 19 (XTAL2_SYS).

JUMPER DESCRIPTION

There are no jumpers on this board.

INPUT/OUTPUT

Status led (yellow) with name **STAT** – this led shows that +3.3V is applied to the board.

CONNECTOR DESCRIPTIONS

UEXT

Pin #	Signal Name
1	3.3V
2	GND
3	RXD
4	TXD
5	STAT
6	RST
7	CTS
8	RTS
9	DSR
10	DTR

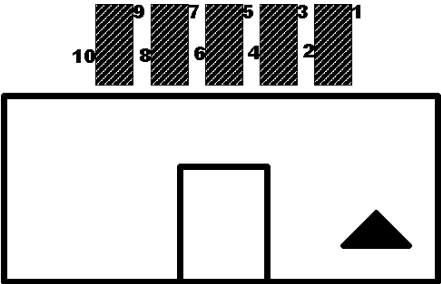

POWER SUPPLY OUTLETS



MECHANICAL DIMENSIONS

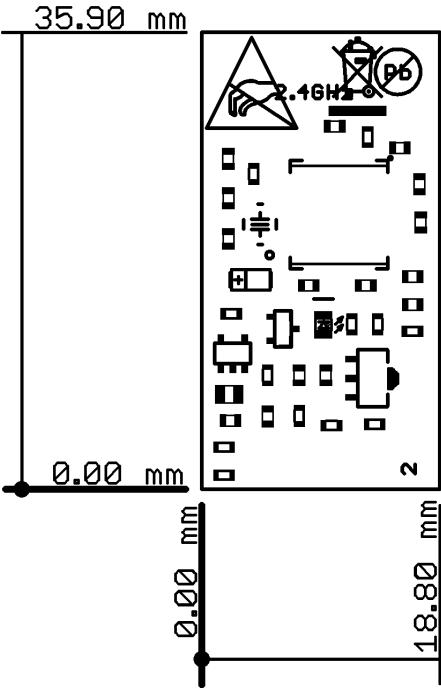

TEXT DIMENSIONS

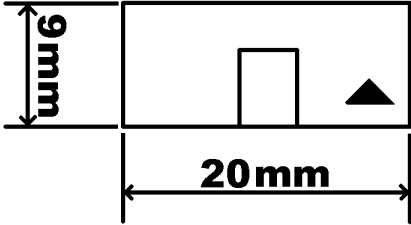

ORDER CODE

MOD-BT – completely assembled and tested

How to order?

You can purchase directly from our online shop or from any of our distributors.

Check our web <https://www.olimex.com/> for more info.

Revision history:

REV. B – initial release – September 2009

REV.C – added more info about the exact chip used – July 2016

Disclaimer:

© 2016 Olimex Ltd. All rights reserved. Olimex®, logo and combinations thereof, are registered trademarks of Olimex Ltd. Other terms and product names may be trademarks of others.

The information in this document is provided in connection with Olimex products. No license, express or implied or otherwise, to any intellectual property right is granted by this document or in connection with the sale of Olimex products.

Neither the whole nor any part of the information contained in or the product described in this document may be adapted or reproduced in any material from except with the prior written permission of the copyright holder.

The product described in this document is subject to continuous development and improvements. All particulars of the product and its use contained in this document are given by OLIMEX in good faith. However all warranties implied or expressed including but not limited to implied warranties of merchantability or fitness for purpose are excluded.

This document is intended only to assist the reader in the use of the product. OLIMEX Ltd. shall not be liable for any loss or damage arising from the use of any information in this document or any error or omission in such information or any incorrect use of the product.