

# Panasonic Industrial Company

## FERRITE CORES FOR NOISE REDUCTION



Devices and Components Division, Taimei Plant  
Kyushu Matsushita Electric Co., Ltd.

Panasonic Industrial Co.  
CTG  
2 Panasonic Way  
Secaucus, New Jersey, 07094  
Tel: 201.348.7894 Fax: 201.392.4888

# Panasonic Industrial Company

Standard quality of materials and characteristics

Quality of materials			NiZn type	MnZn type
			KR16	KR50
Initial permeability	u <sub>iac</sub>	—	1100	5000
Flux density	B <sub>s</sub>	mT	300	400
Retentivity	B <sub>r</sub>	mT	100	70
Coercive force	H <sub>c</sub>	A/m	22	6
Relative loss factor		x10	2	2.5
Temperature factor	a <sub>uy</sub>	X10	7	1
Curie temperature	T <sub>c</sub>	°C	> 140	> 130
Resistivity	rho	Omega-m	10	1
Density	d	kg/m	5000	5000

# Panasonic Industrial Company

## TT Series (Ring Core)

TT Series is effective for general purpose noise reduction such as for power circuit, motor area, and TV circuits.

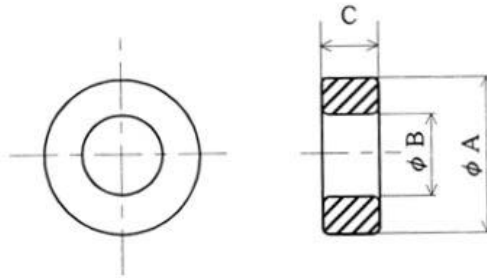

PART NUMBER	DIMENSIONS			IMPEDANCE		
	A	B	C	30MHz	50MHz	100MHz
KR16TT090610	9.0	6.0	10.0	30	38	56
KR16TT100510	9.5	4.9	10.4	40	50	70
KR16TT110620	10.7	6.4	20.0	72	88	110
KR16TT120805	12.0	8.0	5.5	20	27	42
KR16TT120815	12.0	8.0	15.0	35	50	80
KR16TT130706	13.0	7.1	6.3	30	40	55
KR16TT140620	14.3	6.4	20.0	120	140	140
KR16TT140629	14.3	6.4	28.6	200	220	175
KR16TT160828	16.0	7.8	28.0	150	180	170
KR16TT160918	16.0	9.0	18.0	80	95	110
KR16TT160928	16.0	9.0	28.0	120	140	140
KR16TT161208	16.0	12.0	8.0	20	30	45
KR16TT181006	18.0	10.0	6.0	30	40	55
KR16TT181010	18.0	10.0	10.0	35	50	80
KR16TT191008	18.5	10.0	8.0	42	51	68
KR16TT191010	18.5	10.0	10.0	35	50	80
KR16TT191029	18.5	10.0	29.0	130	150	150
KR16TT201110	20.5	10.6	10.3	55	65	80
KR16TT201112	20.5	10.6	12.0	65	75	95
KR16TT221406	22.0	14.0	6.0	25	30	48
KR16TT221410	22.0	14.0	10.0	35	45	60
KR16TT251508	25.0	15.0	8.0	35	44	64
KR16TT251512	25.0	15.0	12.0	35	50	80
KR16TT261329	26.0	13.0	29.0	155	170	160
KR16TT281807	28.5	18.0	7.5	30	40	60
KR16TT281815	28.5	18.0	15.0	53	67	88

Measuring wire: UL1015 AWG # 14, 100mm, 1turn

# Panasonic Industrial Company

## FP Series (Flat Cable Core)

FP Series is effective for noise reduction for flat cables.

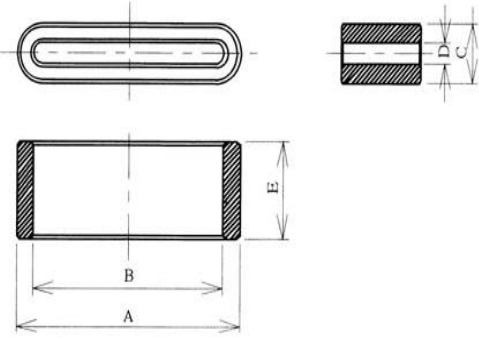

PART NUMBER	DIMENSIONS					IMPEDANCE			
	A	B	C	D	E	30MHz	50MHz	100MHz	wire
KR16FP220610	22.5	17.5	6.0	1.0	10.3	32	40	56	* 1
KR16FP340710	33.5	27.0	6.5	1.3	10.0	28	38	73	* 3
KR16FP340812	33.5	28.5	7.5	2.5	12.0	25	32	53	* 2
KR16FP360709	36.0	31.0	6.5	1.5	9.0	23	30	48	* 2
KR16FP400710	40.0	34.8	6.5	1.3	10.0	24	34	65	* 2
KR16FP450712	45.2	40.0	6.5	1.3	12.0	28	40	83	* 3

Measuring wire \* 1: 1UEW 0.5, 50mm, 1turn  
 \* 2: UL1007 AWG26, 65mm, 1turn  
 \* 3: 1UEW 0.5, 100mm, 1turn

# Panasonic Industrial Company

## KRCB Series (Compartment Case Core)

KRCB Series is effective for noise reduction on AC power cable for PC's and other electronic devices. Their "snap-on" construction allows for easy installation at any point in the production cycle.

Case Color : Black or White  
 Material of Case : Nylon 66  
 Material of Core : KR16

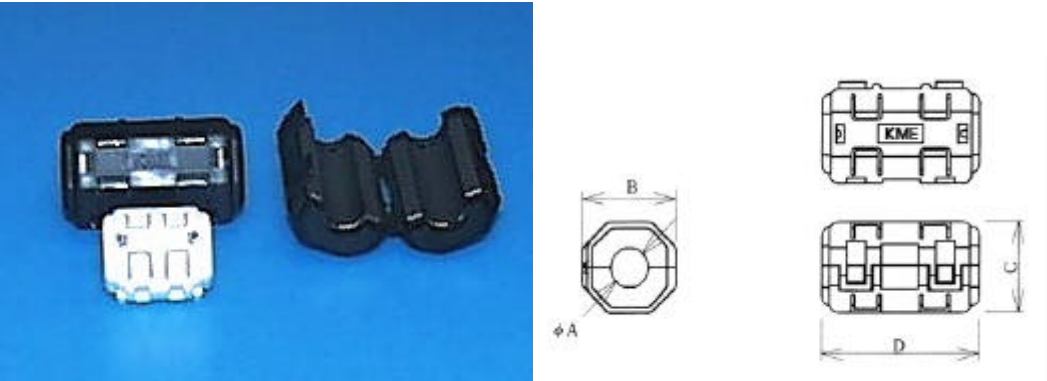

PART NUMBER	DIMENSIONS				IMPEDANCE		
	A	B	C	D	30MHz	50MHz	100MHz
KRCBC130714B	6.5	19.0	15.5	21.0	35	50	80
KRCBG130714	6.5	19.0	15.5	21.0	35	50	80
KRCBC160928B	8.5	22.0	21.0	37.0	110	140	140
KRCBN160928	8.5	22.0	21.0	37.0	110	140	140
KRCBC261329B	12.8	33.0	31.5	34.0	130	160	170

Measuring wire: UL1015 AWG # 14, 100mm, 1turn

# Panasonic Industrial Company

## TA/TB Series (Ring Core with Casing)

TA/TB Series is effective for low frequency noise reduction.

TB Series has Fixed Hole.

Material of Case : PP



TA Series

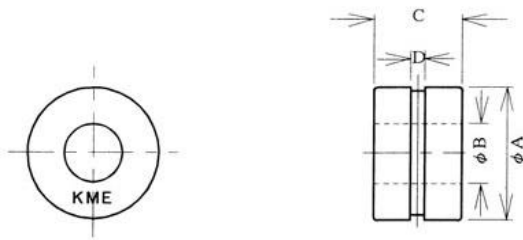

TB Series

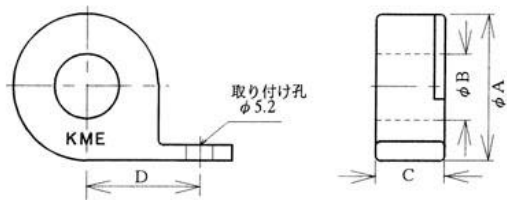

PART NUMBER	DIMENSIONS				IMPEDANCE		
	A	B	C	D	30MHz	50MHz	100MHz
KR16TA191010W	19.6	8.7	11.0	MAX 1.0	35	50	80
KR16TA251512W	26.5	13.5	14.0	MAX 3.0	35	50	80
KR16TB251512B1	29.5	13.4	13.5	23.0	35	50	80

PART NUMBER	DIMENSIONS				IMPEDANCE		
	A	B	C	D	1MHz	5MHz	10MHz
KR50TA251512B	26.5	13.5	14.0	MAX 3.0	20	18	14

Measuring wire: UL1015 AWG # 14, 100mm, 1turn