

RODUCT NUMBER	MATERIAL COLOR	MATERIAL TYPE	DIMENSION A (MM)
66177-001	BLUE	PBT	5.97
66177-002	BLACK	PBT	
66177-003	BLUE (HIGH TEMP)	PBT	
66177-004	BLACK (HIGH TEMP)	PCT OR PA9T	
66177-005	GRAY	PBT	8.80±0.20
66177-006	BLUE	PBT	8.80±0.20
66177-006	BLACK	PCT OR PA9T	8.80±0.20

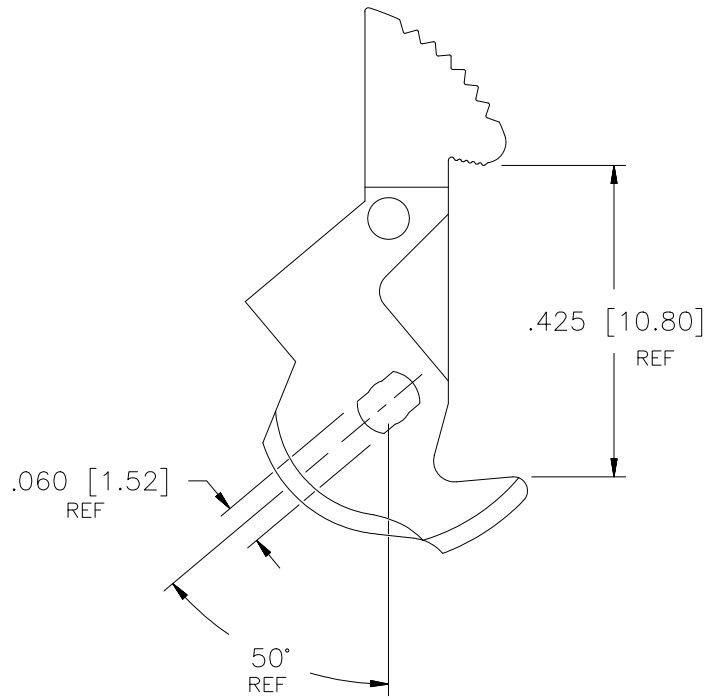
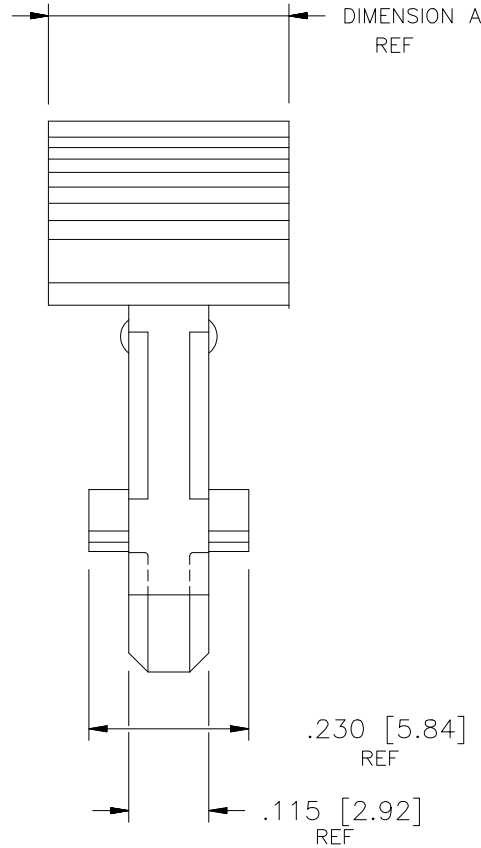

NOTE:

- MOLDING MAT'L: GLASS FILLED POLYESTER, FLAME RETARDENT PER UL-94V-0. COLOR; SEE TABLE
- ADD "LF" SUFFIX AT THE END OF PART NUMBER FOR LEAD FREE OPTION.
- IF "LF" P/N THE PRODUCT MEETS EUROPEAN UNION DIRECTIVES AND OTHER COUNTRY REGULATION AS DESCRIBED IN GS-22-008.
- THE HOUSING WILL WITHSTAND EXPOSURE TO 260° PEAK TEMPERATURE FOR 15 SECONDS IN A WAVE SOLDER APPLICATION WITH A 1.5mm MINIMUM THICKNESS CIRCUIT BOARD. SEE APPLICATION NOTES/PROCEDURES IF THEY ARE AVAILABLE.

mat'l. code		surface ISO 1302 ✓		tolerance ISO 406 ISO 1101		projection INCH/MM		product family QUICKIE	
ltr	ecp no	dr	date	tolerances unless otherwise specified		title		sheet 1 of 1 size	
B	NONE	RDS	5/6/88	angles	.XX±.01/0.25	SEA-HORSE LATCH		A3	
C	V61149	EPK	8/16/96	linear	.XXX±.005/0.13	LOW PROFILE		66177	
D	N06-0027	DT	1/24/06	0°±2°	XXXX±.0020/0.05	scale 3:1		type Product Customer Drawing	
E	N06-0112	LONG	4/18/06	dr	D. SHEAFFER	5/6/88		Amphenol FCI	
F	ELX-N-24793	MZ	8/31/16	enr	R. DOUTRICH	5/6/88		66177	
G	ELX-N-41277	MKX	6/24/21	chr	R. DOUTRICH	5/6/88		66177	
				appd	R. DOUTRICH	5/6/88		66177	
sheet index	revision	G							
	sheet	1							